

TECHNICAL MANUAL
OPERATOR, UNIT, DIRECT SUPPORT
AND GENERAL SUPPORT

MAINTENANCE MANUAL
FOR

COMPRESSOR UNIT,
RECIPROCATING
5.0 CFM, MODEL CAPITANO-PD
(NSN 4310-01-107-8006)

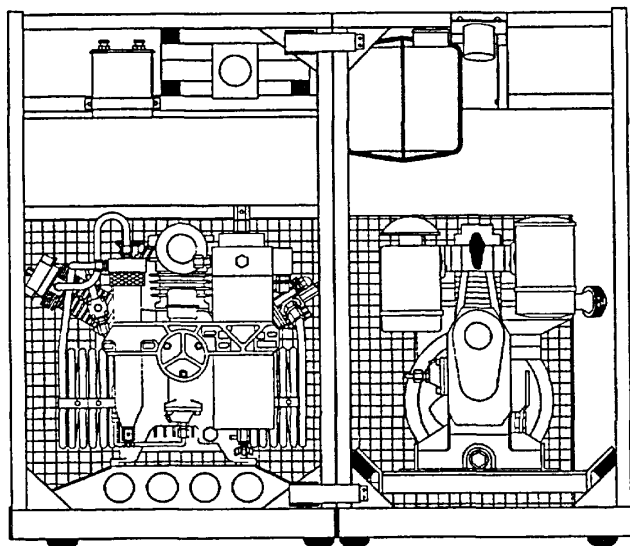

Introduction	1-1
Operating Instructions	2-1
Operator Maintenance Instructions	3-1
Unit Maintenance Instructions	4-1
Direct Support Maintenance Instructions	5-1
General Support Maintenance Instructions	6-1
References	A-1
Maintenance Allocation Chart	B-1
Components of End Item and Basic Issue Items	C-1
Additional Authorization List	D-1
Expended/Durable Supplies and Materials List	E-1
Illustrated List of Manufactured Items	F-1
Torque Limits	G-1

DISTRIBUTION STATEMENT A: Approved for public release; distribution is unlimited.

HEADQUARTERS, DEPARTMENT OF THE ARMY
MARCH 1999

SAFETY SUMMARY

This publication describes physical and chemical processes which may require the use of chemicals, solvents, paints, or other commercially available material. The user of this publication should obtain the material safety data sheets (Occupational Safety and Health Act (OSHA) Form 20 or equivalent) from the manufacturers or suppliers of Materials to be used. The user must become completely familiar with the manufacturer/ supplier information and adhere to the procedures, recommendations, warnings and cautions of the manufacturer/supplier for the safe use, handling, storage and disposal of these Materials. The following are general safety precautions and instructions that people must understand and apply during many phases of operation and maintenance to ensure personal safety and health and the protection of DOD property. Portions of this may be repeated elsewhere in this publications for emphasis.

WARNING AND CAUTION STATEMENTS

WARNING and CAUTION statements have been strategically placed throughout this text prior to operation or maintenance procedures, practices or conditions considered essential to the protection of personnel (WARNING) or equipment and property (CAUTION). A WARNING or CAUTION will apply each time the related step is repeated. Prior to starting any task, the WARNINGS or CAUTIONS included in the text for that task shall be reviewed and understood. Refer to the Materials list figure at the beginning of the appropriate manual section for material used during maintenance of this equipment. The detailed warnings for hazardous material only are listed separately in the safety summary as the 'Hazardous Materials Warnings' section.

HAZARDOUS MATERIALS WARNINGS

Warnings for hazardous materials in this manual are designed to warn personnel of hazards associated with such items when they come in contact with them during actual use. Additional information related to hazardous material is provided as required in the text.

WARNING

Improper cleaning methods and use of unauthorized cleaning liquids or solvents can injure personnel and damage equipment. To prevent this, refer to TM 9-247 for further instructions.

WARNING

Never charge storage cylinders above the temperature compensated safe fill pressure. Failure to follow this warning may cause personnel injury, death, or equipment damage.

WARNING

Care should be taken when working around high-pressure air systems. Pressure should always be vented before hoses are connected or disconnected. Failure to follow this warning may result in personnel injury or death.

WARNING

When handling end connections care should be taken not to contaminate the reciprocating compressor unit. Failure to follow this warning may result in personnel injury, death, or damage to equipment.

WARNING

Never exceed a charging rate of 200 psi/min with SCUBA cylinders out of a filling trough or 400 psi/min with cylinders in a filling trough. Failure to follow this warning may result in personnel injury, death or damage to equipment.

WARNING

The TSP cleaning solution is harmful to eyes and skin. Wear chemical protective apron, gloves and goggles/ face shield when handling or working with the solution.

WARNING

Most ultraviolet lamps contain mercury. Extreme caution should be taken not to break the mercury vapor lamp which will contaminate the component or pipe being inspected and may also cause human injury.

WARNING

Prior to performing maintenance procedures which require removal or disassembly of the reciprocating compressor unit, maintenance personnel should review general guidelines on removing and installing components on life support systems. Failure to follow procedures may result in system contamination.

WARNING

Do not use dry cleaning solvent P-D-680 on any Compressed Air System components. Only use the cleaning agents specified in Chapter 4, Section VII for cleaning Compressed Air System components. Use of unauthorized cleaning agents could result in personnel injury or death.

WARNING

Compressed air used for cleaning or drying purposes, or for clearing restrictions, should never exceed 30 psi (207 kPa). Wear protective clothing (goggles/shield, gloves, etc.) and use caution to avoid injury to personnel.

WARNING

To prevent injury, ensure that work clothes are closely fitting so that they cannot be caught in rotating machinery or projecting parts.

WARNING

To avoid personal injury, avoid trapping fingers between V-belt and sheave while installing V-belt.

WARNING

To ensure as little air contamination as possible, the intake hose must be fully extended and always be located upwind of the engine exhaust. When the wind direction changes, the compressor air intake must be relocated. This action is imperative to ensure that as little contaminated air as possible enters the compressor.

WARNING

CARBON MONOXIDE (EXHAUST GAS) CAN KILL YOU Exposure to exhaust gases produces symptoms of headache, dizziness, loss of muscular control, drowsiness, or coma. Brain damage or death can result from severe exposure. Fumes from engine become concentrated with poor ventilation. Operate engine in a ventilated area only. While running engine, be alert for fumes. Keep area ventilated. If someone is overcome, expose to fresh air, keep warm and still; give artificial respiration if needed. Seek medical attention. Administer oxygen, if available. **GOOD VENTILATION IS THE BEST DEFENSE AGAINST EXHAUST POISONING**

WARNING

Place flat of screwdriver at bottom of sheave between V-belt and sheave. Move screwdriver to 45° to lever belt out of line with sheave. Rotate sheave right (cw) until belt is fully disengaged from sheave groove.

WARNING

Death or serious injury could occur if fuel is not handled carefully. Use in a well-ventilated area away from open flame, arcing equipment, ignition sources, heaters or excessive heat. Engine must be turned off and cool before refueling. Use proper refueling procedures and equipment to avoid spillage. Do not run engine near open fuel containers. **DO NOT SMOKE.**

WARNING

Ensure the unit is shut down and that the system pressure has been bled to zero

WARNING

Serious injury could result from injector spray. Keep hands away from fuel spray.

WARNING

Handling heated parts can cause severe burns. Use proper equipment to handle heated parts.

WARNING

Before starting the engine and after making repairs or adjustments on the fuel system, a 17 mm open end wrench must be available to allow rapid removal of the steel fuel line at the injection pump in case of a runaway condition. Failure to heed this warning could result in injury or personnel and equipment damage.

WARNING

Dry cleaning solvent P-D-680 (safety or Stoddard's Solvent) is potentially dangerous. Avoid repeated and prolonged breathing of vapors and skin contact with liquid. Do not use near open flame, arcing equipment, or other ignition sources. Always wear eye protection and protective clothing. The flash point of P-D-680 is 100 to 138 degrees F (38 to 59 degrees C).

WARNING

Live steam used for cleaning shall not exceed 100 psi (6-9 bar). Use goggles or face shield for eye protection. Do not direct live steam against skin.

WARNING

Death or serious injury could occur if compressed air is directed against the skin. Do not use compressed air for cleaning or drying unless the pressure has been reduced to 30 psi (2.06 bar) or less. When working with compressed air always use chip guards, eye protection, and other personal safety equipment.

WARNING

Allow engine to come to a complete standstill. Avoid contact with hot oil, exposure may result in scalding or other injuries

WARNING

Dry cleaning solvent P-D-680 is toxic and flammable. Always wear protective goggles and gloves, and use only in a well-ventilated area. Avoid contact with skin, eyes and clothes and DO NOT breathe vapors. DO NOT use near open flame or excessive heat. The solvent's flash point is 100°F-130°F (38°C-59°C). If you become dizzy while using cleaning solvent immediately get fresh air and medical help. If solvent contacts eyes, immediately wash your eyes and get medical aid.

WARNING

Do not use dry cleaning solvent P-D-680 on any Diving Life Support Air System components. Only use the cleaning agents specified in Chapter 4, Section VII for cleaning Diving Life Support Air System components. Use of unauthorized cleaning agents could result in personnel injury or death.

WARNING

The final oil/water separator is subject to dynamic loading. It is designed to operate for up to 90,000 hours. After reaching the maximum number of hours, the final oil/water separator should be replaced.

**OPERATOR, UNIT, DIRECT SUPPORT
AND GENERAL SUPPORT
MAINTENANCE MANUAL
FOR
COMPRESSOR UNIT, RECIPROCATING,
5.0 CFM, MODEL CAPITANO-PD
(NSN 4310-001-107-8006)**

REPORTING ERRORS AND RECOMMENDING IMPROVEMENTS

You can help improve this manual. If you find any mistakes or if you know of a way to improve the procedures, please let us know. Mail your letter, DA Form 2028 (Recommended Changes to Publications and Blank Forms), or DA Form 2028-2 located in the back of this manual direct to: Director, Armament and Chemical Acquisition and Logistic Activity (ACALA), ATTN: AMSTA-AC-NML, Rock Island, IL 61299-7630 (E-mail amsta-ac-nml@ria.army.mil).

APPROVED FOR PUBLIC RELEASE; DISTRIBUTION IS UNLIMITED.

TABLE OF CONTENTS

	PAGE
HOW TO USE THIS MANUAL	iii
CHAPTER 1 INTRODUCTION	
Section I General Information	1-1
Section II Equipment Description and Data	1-3
Section III Technical Principles of Operation	1-9
CHAPTER 2 OPERATING INSTRUCTIONS	
Section I Description and Use of Operators Controls and Indicators	2-1
Section II Preventive Maintenance Checks and Services (PMCS)	2-3
Section III Operation Under Usual Conditions	2-8
Section IV Operation Under Unusual Conditions	2-15
CHAPTER 3 OPERATOR MAINTENANCE INSTRUCTIONS	
Section I Lubrication Instructions	3-1
Section II Service Upon Receipt of Materials	3-6
Section III Troubleshooting Procedures	3-8
Section IV Operator Maintenance Procedures	3-13

CHAPTER 4	UNIT MAINTENANCE INSTRUCTIONS	
Section I	Repair Parts; Special Tools; Test Measurement and Diagnostic Equipment (TMDE); and Support Equipment	4-1
Section II	Service Upon Receipt	4-1
Section III	Unit Preventive Maintenance Checks and Services	4-2
Section IV	Unit Troubleshooting Procedures	4-5
Section V	Unit Support Maintenance Procedures	4-11
Section VI	Preparation for Storage or Shipment	4-34
Section VII.	Cleaning Procedures	4-36
CHAPTER 5	DIRECT SUPPORT MAINTENANCE INSTRUCTIONS	
Section I	Repair Parts; Special Tools; Test Measurement and Diagnostic Equipment, (TMDE); and Support Equipment	5-1
Section II	Direct Support Maintenance Instructions	5-1
CHAPTER 6	GENERAL SUPPORT MAINTENANCE INSTRUCTIONS	
Section I	General Information	6-1
APPENDIX A	REFERENCES	A-1
APPENDIX B	MAINTENANCE ALLOCATION CHART	B-1
APPENDIX C	COMPONENT OF END ITEM AND BASIC ISSUE ITEMS	C-1
APPENDIX D	ADDITIONAL AUTHORIZATION LIST.	D-1
APPENDIX E	EXPENDABLE/DURABLE SUPPLIES AND MATERIALS LIST.	E-1
APPENDIX F	ILLUSTRATED LIST OF MANUFACTURED ITEMS	F-1
APPENDIX G	TORQUE LIMITS	G-1

HOW TO USE THIS MANUAL

In this manual, primary chapters and sections appear in upper case/capital letters; paragraphs are presented in numeric sequence with the chapter number listed first, e.g., 4-19, and the title is all upper case/capital letters; subordinate paragraphs are presented in alpha sequence, e.g., (a); the next paragraphs are presented in numeric sequence with the number presented in parenthesis, e.g., (1). The location of additional material that must be referenced is clearly marked. Figures supporting maintenance procedures/test are located as close as possible to their references.

CHAPTER 1 - INTRODUCTION. Chapter 1 contains general information, equipment description and technical principles of operation

CHAPTER 2 - OPERATING INSTRUCTIONS. Chapter 2 contains a description of the end item and each control and indicator is described. Operating procedures include Preventive Maintenance Checks and Services (PMCS), and operation under usual and unusual conditions.

CHAPTER 3 - OPERATOR MAINTENANCE INSTRUCTIONS. Chapter 3 contains lubrication instructions, troubleshooting procedures used to recognize malfunctions/symptom, probable cause and corrective action, and maintenance procedures authorized at operator level

CHAPTER 4 - UNIT MAINTENANCE INSTRUCTIONS. Chapter 4 lists lubrication instructions, troubleshooting procedures used to recognize/symptom, probable cause and corrective action, and maintenance procedures authorized at unit level

CHAPTER 5 - DIRECT SUPPORT MAINTENANCE INSTRUCTIONS Chapter 5 contains information for direct support maintenance on the CAPITANO-PD Reciprocating Compressor Unit

CHAPTER 6 - GENERAL SUPPORT MAINTENANCE INSTRUCTIONS. Chapter 6 contains information for general support maintenance on the CAPITANO-PD Reciprocating Compressor Unit

APPENDIX A - REFERENCES. This appendix lists all the publications referenced in this manual.

APPENDIX B - MAINTENANCE ALLOCATION CHART (MAC) This appendix provides a general explanation of all maintenance and repair functions authorized at various maintenance levels under the standard Army Maintenance System concept.

APPENDIX C - COMPONENTS OF END ITEM (COEI) AND BASIC ISSUE ITEM (BII) LIST. This appendix lists components of the end item and basic issue items to help you inventory the items for safe and efficient operation of the equipment

APPENDIX D - ADDITIONAL AUTHORIZATION LIST. This list identifies Items that do not have to accompany the CAPITANO-PD and that do not have to be turned in.

APPENDIX E -EXPENDABLE/DURABLE SUPPLIES AND MATERIALS LIST. This appendix lists expendable/durable supplies and materials that you will need to operate and maintain the end item. This listing is for information only and is not the authority to requisition the listed items

APPENDIX F - ILLUSTRATED LIST OF MANUFACTURED ITEMS. This appendix includes complete instructions for making items authorized to be manufactured or fabricated at organizational, direct support, and general support maintenance.

APPENDIX G - TORQUE LIMITS. This appendix lists applicable torque values expressed in standard and metric values.

ALPHABETICAL INDEX. The index contains key technical manual subjects arranged in alphabetical order. If you require information on a certain subject (i.e., cleaning), but you are not sure where to look, use the index to locate the specific page.

iii/iv Blank

**CHAPTER 1
INTRODUCTION**

Section I	General Information	Page 1-1
Section II	Equipment Description and Data	1-3
Section III	Technical Principles of Operation	1-9

Section I. GENERAL INFORMATION

Paragraph	Page
1-1 Scope	1-1
1-2 Purpose	1-1
1-3 Maintenance Forms and Procedures	1-1
1-4 Corrosion Prevention and Control (CPC)	1-1
1-5 Reporting Equipment Improvement Recommendations (EIR)	1-2
1-6 List of Abbreviations	1-2
1-7 Destruction of Army Material to Prevent Enemy Use	1-2

1-1. SCOPE.

This technical manual contains descriptive data, operation instructions, setup and storage procedures, and maintenance instructions for a 5.0 CFM, Reciprocating Compressor Unit. The manufacturer's part number for the reciprocating compressor unit is CAPITANO-PD.

NOTE

Where possible, all dimensional values are given in the English system and Metric system. The metric values will appear in parenthesis following the English system value.

1-2. PURPOSE.

The purpose of the reciprocating compressor unit is to provide purified high pressure breathing air.

1-3. MAINTENANCE FORMS, RECORDS, AND REPORTS.

Department of the Army forms and procedures used for equipment maintenance will be those prescribed by DA PAM 738-750, The Army Maintenance Management System (TAMMS).

1-4. CORROSION PROTECTION.

a. Corrosion Prevention and Control (CPC) of Army material is a continuing concern. It is important that any corrosion problems with this item be reported so that the problem can be corrected and improvements made to prevent the problem in future items.

b. While corrosion is typically associated with rusting of metals, it can also include deterioration of other materials, such as rubber and plastic. Unusual cracking, softening, swelling, or breaking of these materials may be a corrosion problem.

c. If a corrosion problem is identified, it can be reported using Standard Form SF 368, Product Quality Deficiency Report. Use of key words such as "corrosion," "rust," "deterioration," or "cracking" will ensure the information is identified as a CPC problem.

d. The form should be submitted to the address specified in DA 738-750.

1-5. REPORTING EQUIPMENT IMPROVEMENT RECOMMENDATIONS (EIR).

If your model CAPITANO-PD compressor unit needs improvement, let us know. Send us an EIR. You, the user, are the only one who can tell us what you don't like about our equipment. Let us know why you don't like the design or performance. Put it on a SF-368 (Quality Deficiency Report). Mail it to us at: Commander, U.S. Army Tank Automotive and Armaments Command (TACOM) ATTN, AMSTA-AC-NML Rockland, IL 61299-7630. A reply will be furnished to you.

1-6. LIST OF ABBREVIATIONS.

cfm	Cubic feet per minute
lpm	Liters per minute
rpm	Revolutions per minute
psi	Pounds per square inch
hp	Horsepower
cc	Cubic centimeter
qt	Quart
in	Inch
lbs	Pounds
bar	Bar
Nm	Newton-meter
lb-ft	Pound-foot
CO	Carbon monoxide
CO ₂	Carbon dioxide
cu ft	Cubic foot
cu In	Cubic inch
cu m	Cubic meter
gal	Gallon
PMCS	Preventive Maintenance Checks and Services
MAC	Maintenance Allocation Chart
PMV	Pressure Maintaining Valve
cm	Centimeter
mm	Millimeter
TDC	Top Dead Center

1-7. DESTRUCTION OF ARMY MATERIAL TO PREVENT ENEMY USE.

The procedures for destroying Army material to prevent enemy use are listed in TM 750-2443.

Section II. EQUIPMENT DESCRIPTION AND DATA

Paragraph	Page
1-8 Equipment Characteristics, Capabilities and Features	1-3
1-9 Equipment Data	1-4
1-10 Differences Between Models	1-5
1-11 Safety, Care, and Handling.....	1-8

1-8. EQUIPMENT CHARACTERISTICS, CAPABILITIES AND FEATURES.

Equipment characteristics, capabilities and features of the model CAPITANO-PD reciprocating compressor unit consist of a high pressure compressor driven by a one cylinder diesel engine through a V-belt (Figure 1-1 and 1-2). The unit includes gauges, hourmeters, fuel tank, purification system and a two part portable frame. The model CAPITANO-PD is capable of providing 5.0 cubic feet per minute of free air compressed to 3200 psi The unit can be operated in temperatures ranging from 0° F to 110° F (-17.8° C to 43° C).

a. Compressor The compressor will deliver 5.0 cfm of breathing air compressed to 3200 psi. The cylinders are arranged in a "W" configuration The first stage is in the center, with the second stage on the left and the Compressor. The compressor is a three cylinder, three stage reciprocating piston, air-cooled third stage on the right when facing the impeller/pulley. Lubrication of the third stage IS provided by a high-pressure oil pump. The first and second stages are splash lubricated. The cylinders of the compressor, the intercoolers and the aftercoolers are air-cooled. Cooling air Is drawn across the compressor by an axial fan impeller/pulley driven by the diesel engine An intermediate filter is installed between the 2nd and 3rd stages It includes a centrifugal plate to remove entrained air and oil and a sintered metal filter element to remove solid particles.

b. Diesel Engine. The air-cooled, four-cycle, one cylinder diesel engine develops 6 hp at 3600 rpm. An axial fan impeller cools the engine The engine is started by use of a hand crank.

c. Fuel Tank. The fuel tank is mounted above the engine, and is attached to the engine unit frame (Figure 1-1). It has a 2.38 gal (9 l) capacity with no reserves.

d. Purification System. The purification system consists of an oil/water separator and a dryer/purifier. The oil/water separator after the third stage includes a coalescing element for removal of oil and water aerosols. The dryer/purifier contains a replaceable cartridge for removal of oil and water vapors and conversion of CO to CO₂. The design of the dryer/purifier requires that a cartridge filter be properly installed in order to maintain pressure on the system. This ensures that only treated air will be available for filling delivery.

e. Frame. The frame consists of two sections, one section provides mounting for the reciprocating compressor, while the other provides mounting for the diesel engine. Each section is a welded fabrication of square steel tubing and angles. The sections are separately portable as four man carries Alignment studs are provided on the compressor frame, located at the top and bottom corners. These studs fit snugly into the corresponding open receptacles incorporated into the engine frame For assembly of the two sections, the alignment studs of the compressor frame are inserted into the engine frame until the frames are tight together. Adjustable draw latches are provided for securing the two sections together in alignment for operation.

f. Drive. After the frame sections are secured together, a V-belt is installed over the pulleys of the engine and compressor and belt guards are bolted on, completing the assembly of the unit and providing drive capability for the compressor by the diesel engine.

g. Intercoolers and Aftercoolers. Intercoolers are provided between stages 1 and 2, and between stages 2 and 3 An aftercooler is situated between stage 3 and the final oil/water separator. Compressed air is cooled as it advances between stages and before final delivery.

h. Safety Relief Valves. Each compression stage is protected by a safety relief valve.

i. Instruments and Gauges. Instruments and gauges consist of hourmeters to record time of operation and gauges for pressure indication. An hourmeter is mounted on the gauge panel of each frame. A pressure gauge is also installed at the discharge end of the delivery hose.

CAUTION

THE DIESEL ENGINE AND COMPRESSOR ARE BUILT TO METRIC STANDARD MEASUREMENT. THE FRAME AND MOUNTING EQUIPMENT ARE MANUFACTURED USING ENGLISH STANDARD SIZES. DO NOT USE IMPROPER TOOL SIZES FOR MAINTENANCE OR REPAIRS. USE THE RIGHT TOOL FOR THE JOB.

1-9. EQUIPMENT DATA.

The equipment data for the model CAPITANO-PD and its components are listed in Table 1-1.

Table 1-1. Equipment Data/Characteristics

Engine

Manufacturer	Hatz Diesel Co.
Model	E673 LHK
Type	Four-stroke air-cooled diesel
Horsepower	6 @ 3600 rpm
Number of cylinders	1
Bore	2.8740 in (73.0 mm)
Stroke	2.6378 in (67.0 mm)
Compression ratio (nominal)	19 to 1
Total displacement	17 4 cu in (280 cc)
Direction of rotation (facing throttle control)	Clockwise
Cooling air required	180 cfm (5 cu m/min)
Injection pressure	1920 psi (133 bar)
Tappet clearance (cold engine)	
Compression tappet	0 004 in (0 10 mm)
Decompression tappe	t0.10 in (1.0 mm)

Engine Accessories

Air cleaner	Oil bath
Fuel Tank (capacity)	2.38 gal (9.0 l)
Crankcase (capacity)	1.1 qt (1 l)

Compressor

Manufacturer	Bauer Compressors, Inc.
Model	CAPITANO-PD
Number of cylinders	3
Working process	3 stage
Cylinder bore	2.76, 1.42, 0.58 in (70 / 36 14 mm)
Piston stroke	1.57 in (40 mm)
Compressor speed	1300 rpm
Intermediate pressure	56 / 500 / 3200 psi (4 / 35 /221 bar)
Oil pressure (nominal)	850 psi (60 bar)
Free air delivery	5 0 cfm (140 lpm)
Power required	6 hp (4 5 kw)
Oil capacity	1 5 qt (1.42 l)

Table 1-1. Equipment Data / Characteristics

Purification	
Purification system	P2
Cartridges required	1
Dimensions	
Drive section	
Unit weight (dry)	196 lbs (88391 kg)
Volume	.991 cu ft (0.281 cu m)
Length	19.9375 in (50.64 cm)
Width	23.375 in (59.37 cm)
Height	36.75 in (93.345 cm)
Compressor section	
Unit weight (dry)	190 lbs (86.18 kg)
Volume	11.79 cu ft (0.334 cu m)
Length	.21.75 in (55.25 cm)
Width	25.5 in (64.77 cm)
Height	36.75 in (93.345 cm)
Combined unit	
Weight	386 lbs. (175.24 kg)
Volume	22.61 cu ft (0.64 cu m)
Length	41.6875 in (105.84 cm)
Width	25.5 in (64.77 cm)
Height	36.75 in (93.345 cm)
Accessories	
Drive belt	
Size	AP78
Quantity required	1

1-10. DIFFERENCES BETWEEN MODELS.

Model CAPITANO-PD reciprocating compressor unit is the only provisioned model for this 5.0 CFM Air Compressor Unit It is supported by TM 5-4310-393-14 and TM 5-4310-393-24P

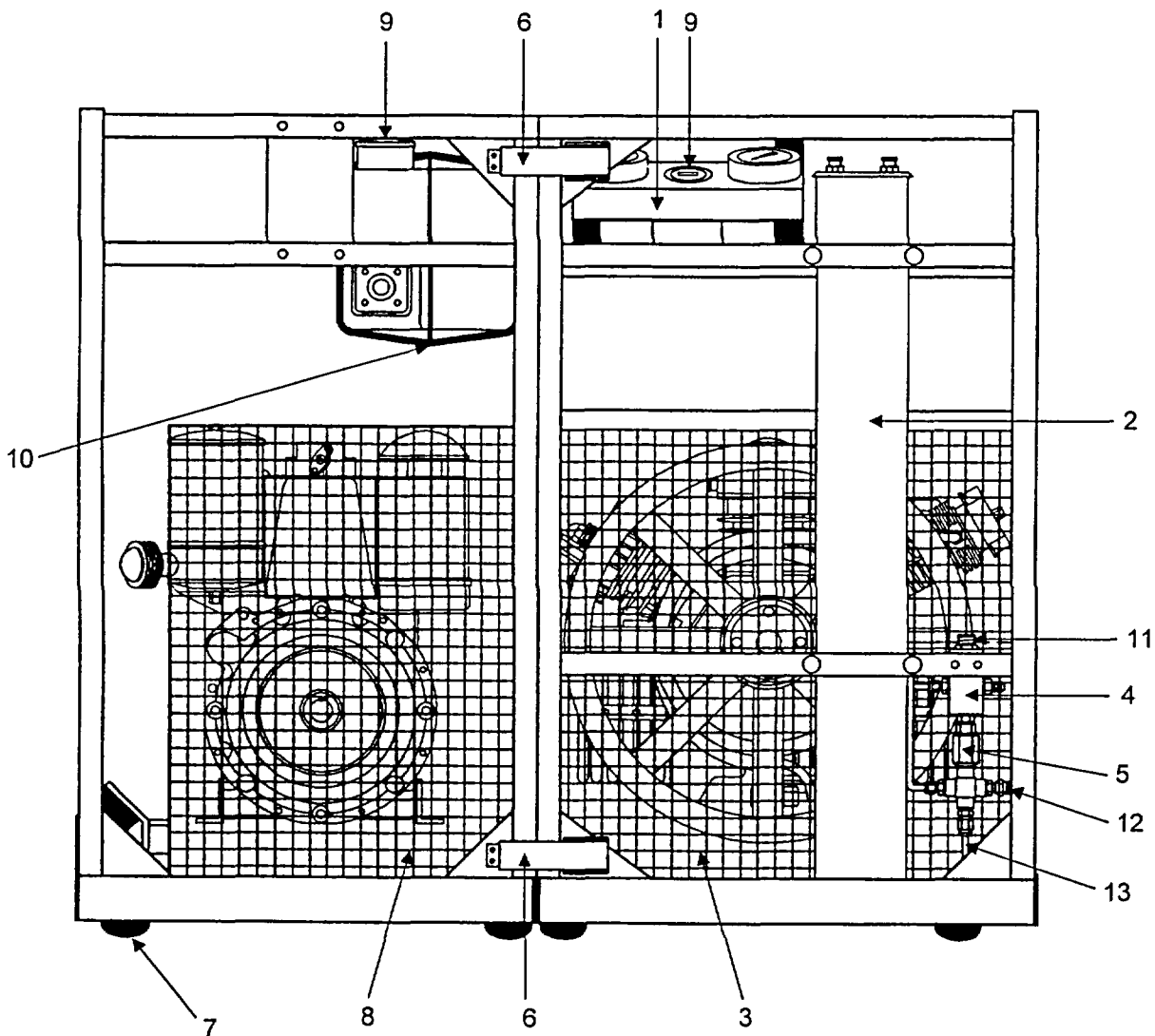

- 1. Instrument Panel
- 2. Purification Cylinder
- 3. Compressor Belt Guard
- 4. Pressure Maintaining Valve
- 5. Check Valve

- 6. Draw Latch
- 7. Mounting Foot
- 8. Engine Belt Guard
- 9. Engine Hourmeter
- 10. Diesel Fuel Tank

- 11. Pressure Adjusting Screw
- 12. Bleed Valve
- 13. Drain Line

FIGURE 1-1. FRONT VIEW

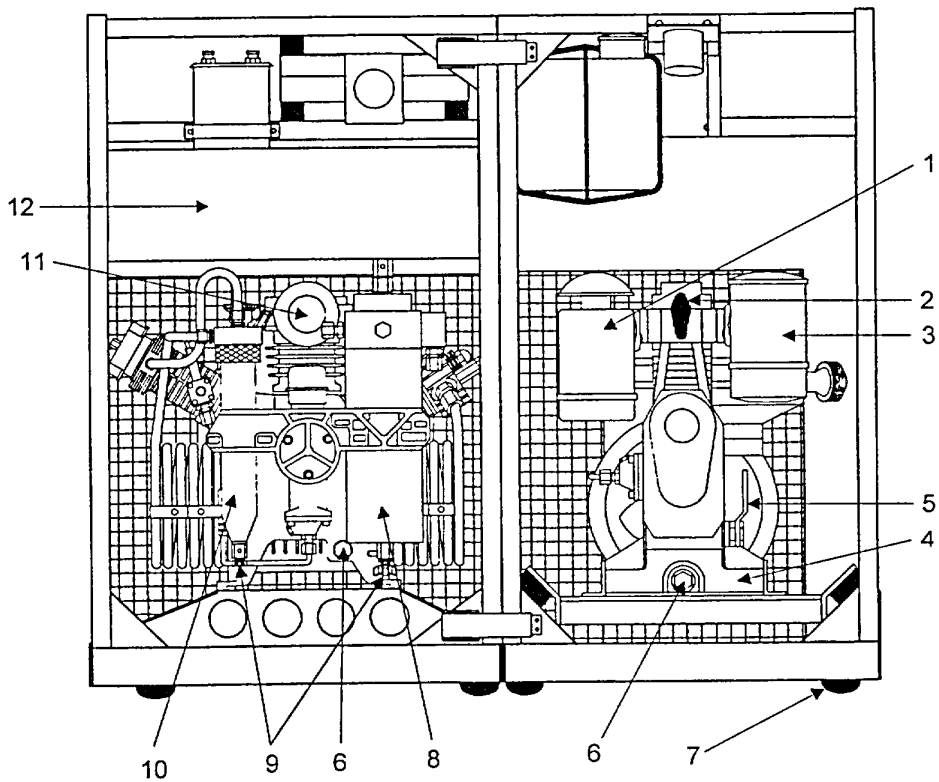

- | | | |
|-------------------------|--------------------------------|---|
| 1. Engine Air Cleaner | 2. Decompression Lever | 3. Engine Exhaust Muffler with Spark Arrester |
| 4. Diesel Engine | 5. Throttle Lever | 6. Engine Oil Drain Plug |
| 7. Mounting Foot | 8. Final Oil & Water Separator | 9. Manual Condensate Drain Valves |
| 10. Intermediate Filter | 11. Compressor Air Cleaner | 12. Hose Tray |

FIGURE 1-2. REAR VIEW

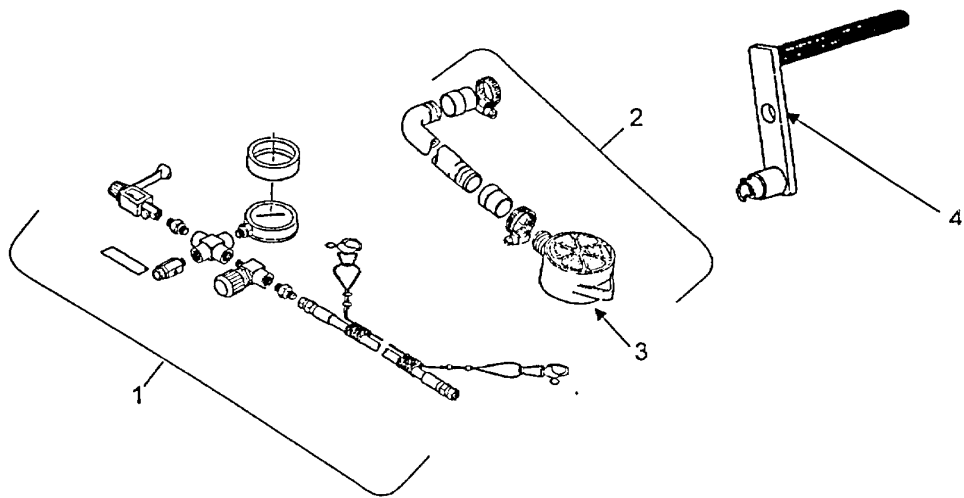

- | | | | |
|-----------------------|-------------------------|---------------|-----------------|
| 1. Fill Whip Assembly | 2. Intake Hose Assembly | 3. Pre-Filter | 4. Crank Handle |
|-----------------------|-------------------------|---------------|-----------------|

FIGURE 1-3. ANCILLARY EQUIPMENT VIEW

1-11. SAFETY, CARE, AND HANDLING.

- a. This manual is not intended to dictate safe diving operations or procedures. Diving supervisors are ultimately responsible for conducting safe diving operations in accordance with approved regulations and instructions
- b. Always shut down and depressurize the system, using the purge valve, to carry out any work on the compressor. Failure or observe this warning may result In injury or death to personnel.
- c. Never resolder or reweld pressure lines.
- d. Check for leakage of the complete system from time by brushing all fittings and couplings with non-ionic detergent water solution. Remedy any leakage.
- e. Connecting hoses must be In satisfactory condition and threads undamaged. Pay particular attention to damage on the interface from hose fitting to hose. If the rubber is scored, or wire-braided hose is frayed, the hose must be discarded.
- f. Leave 1¹/₂ threads or the first few threads of a fitting exposed when applying Teflon tape. This will ensure no Teflon tape will hang down into the air or fuel system. Teflon tape should be wrapped in such a manner that when the fitting is tightened, the tape will not loosen Incorrectly wrapped tape may result in contamination or blockage of the air or fuel system and subsequent possible injury to the diver.
- g. Ensure that all air lines and components removed are inserted into a plastic bag and sealed, and that FMEC (Foreign Material Enclosure Caps) are inserted into openings. Failure to do so can cause the air system to become contaminated and could result in injury or death to the diver.
- h. Do not use trichloroethylene or methyl chloroform in cleaning operations associated with any diving system Use of either chemical or similar contaminants can result in death when operators/divers are exposed to these contaminants under pressure. These contaminants are not water soluble. If contamination or suspected contamination occurs, immediately discontinue all diving equipment operations and notify Commander, U S Army Engineering Center, DSN 676-7309 / and 7325 Commercial (314) 563-7309. The only acceptable cleaning agents are tribasic sodium phosphate and non-ionic detergents (NID).
- i. Remove all traces of lacquer thinner with non-ionic detergent solution and rinse with fresh water Residual lacquer thinner will contaminate atmosphere and may cause injury or death to personnel
- j. Repair or replace worn or damaged parts immediately with authorized parts. Failure of a component during equipment usage could result in injury or death to personnel.
- k. Clean mechanical parts and softgood components in accordance with NEDU instruction 7121.A.

CAUTION**TO AVOID DAMAGE, REMOVE THE HOURMETERS BEFORE CLEANING THE ENGINE OR COMPRESSOR UNIT WITH HIGH PRESSURE WATER/STEAM.**

l. The engine and compressor can be cleaned with a pressurized cleaning system (steam cleaner), but care must be taken. Cap off engine and compressor intakes. Do not spray water (steam) directly into the instruments or back of the instrument panel. If possible, dry with low pressure compressed air and run the unit immediately after washing to prevent rust and corrosion.

Section III. TECHNICAL PRINCIPLES OF OPERATION

Paragraph		Page
1-12	Compressor	1-9
1-13	Pneumatic Air Flow	1-9
1-14	Purifiers	1-9

1-12. COMPRESSOR.

The compressor is driven at a speed of 1300 rpm. When a pressure of 3200 psi is reached in the vessel being filled, the safety relief valve on the fill hose assembly will open to atmosphere. The first stage of the compressor block is connected to the second stage with a tube that serves as an intercooler. The purpose of the intercooler is to reduce the interstage temperature of the air, increasing the unit volume and ultimately the volumetric capacity for the entire multi-stage reciprocating compressor.

The second stage discharge is passed through another intercooler to an oil/water separator, and then to the inlet of the third stage. The third stage discharges to an aftercooler tube which is connected to a final oil/water separator. From the final oil/water separator, the air is tubed to a final purification cartridge and then through a pressure maintaining valve to a service port.

Manual condensate drain valves are provided at each of the two oil/water separators. These separators should be drained every 15 to 20 minutes during operation of the compressor, and after the unit is shutdown for the day.

1-13. PNEUMATIC AIR FLOW.

Refer to Figure 1-3 Compressed Air Pneumatic Flow Diagram. The 1st stage draws in atmospheric air through an intake prefilter (1). The air then goes through the intake hose (2), and through a 10 micron intake air cleaner filter (3). The air is drawn into the first stage cylinder (4) and is compressed to 56 psi (4 bar). The pressurized air is cooled between the first and second stages by an Intercooler (5). In the second stage cylinder, air is compressed to 500 psi (35 bar) and then passes through a second Intercooler (7) and enters an oil/water separator (8). From the oil/water separator (8) the air enters the third stage cylinder (9), where it is compressed to 3200 psi (221 bar), the operating pressure of the unit. The air is cooled again by passing through an aftercooler tube (10) and most remaining oil/water is removed by the final oil/water separator (11). The air is then cleaned by the purification cylinder (13). Air leaving the purification cylinder goes through a pressure maintaining valve. A fill hose assembly is provided between the pressure maintaining valve and the service air outlet (20). Air pressures are safety maintained by safety relief valves at each compressor stage and by a safety relief valve placed in the fill hose assembly. Check valves (12) are installed on each side of the purification cylinder to prevent back flow of air into the system from a service air cylinder which might be above system pressure or contaminated. Manually operated drain valves (15 and 16) are installed for each oil/water separator (8 and 11). The purification purge valve (17) will depressurize the system when opened.

1-14. PURIFIERS

The compressed air is rendered free from most of the heavy oil and water by an oil/water separator between the second and third stage, and by an oil/water separator after the third stage. Final purification of the air is accomplished by the purification cylinder located after the final oil/water separator. The purification cylinder contains a dryer/purifier cartridge which removes all residual oil and water vapors, providing treated air, free of oil, taste, and odor for respiratory use by divers.

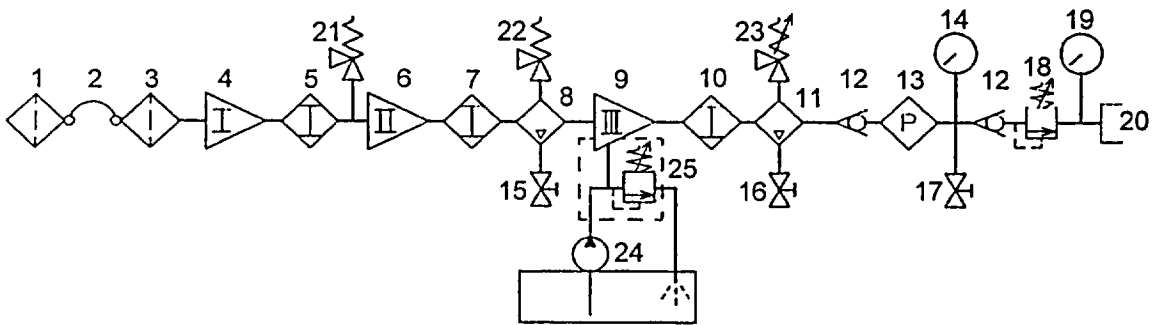

- | | |
|--------------------------------------|---|
| 1. Remote Intake Prefilter | 14. Filter System Pressure Gauge |
| 2. Intake Hose | 15. 2 nd Stage Manual Condensate Drain Valve |
| 3. Intake Air Cleaner Filter | 16. 3 rd Stage Manual Condensate Drain Valve |
| 4. Compressor 1 st Stage | 17. Purification Purge Valve |
| 5. 1 st Stage Intercooler | 18. Pressure Maintaining Valve (PMV) |
| 6. Compressor 2 nd Stage | 19. Service Line Pressure Gauge |
| 7. 2 nd Stage Intercooler | 20. Service Air Outlet |
| 8. 2 nd Stage Separator | 21. 1 st Stage Safety Relief Valve |
| 9. Compressor 3 rd Stage | 22. 2 nd Stage Safety Relief Valve |
| 10. Aftercooler | 23. 3 rd Stage Safety Relief Valve |
| 11. Final Oil/Water Separator | 24. Oil Pump |
| 12. Check Valve | 25. Oil Pressure Regulating Valve |
| 13. Purifier | |

Figure 1-4. Pneumatic Air Flow Diagram

CHAPTER 2

OPERATING INSTRUCTIONS

	Page
Section I Description and Use of Operators Controls and Indicators	2-1
Section II Preventive Maintenance Checks and Services (PMCS)	2-3
Section III Operation Under Usual Conditions	2-7
Section IV Operation Under Unusual Conditions	2-15

Section I. DESCRIPTION AND USE OF OPERATORS CONTROLS AND INDICATORS

Paragraph	Page
2-1 General	2-1
2-2 Operator's Control and Indicators	2-1
2-3 Safety Devices.....	2-1

2-1. GENERAL.

The instrument panel for the compressor unit is mounted on the compressor frame. It includes a filter system pressure gauge, a service line pressure gauge and an hourmeter. The instrument panel for the engine unit includes an hourmeter only Labels are installed in identifying the service of each instrument. Separate mounting brackets are provided for each hourmeter, labeled HOURMETER ON and HOURMETER OFF. The hourmeters are designed to record operating time by vibration of the unit while the instrument face is in a horizontal position. The HOURMETER OFF bracket allows installation of the hourmeter with the face in a vertical position to permit transportation of the model CAPITANO-PD without creating an error in the operating hours record.

2-2. OPERATOR'S CONTROLS AND INDICATORS.

Figure 2-1 and Table 2-1 provide a general description of the operator's controls and indicators for the model CAPITANO-PD split frame breathing air reciprocating compressor unit.

2-3. SAFETY DEVICES.

a. Purification Cylinder Venting Bore. The purification cylinder is arranged to allow air to escape if the cartridge is missing or not properly seated in place. With the cartridge in place, the vent closes, allowing air pressure to build up. This safety device, located inside purifier cylinder, prevents the operator from delivering unpurified air.

b. Drain/Purge Valves. Drain valves, located at the bottom of the oil/water separators, allow pressure and accumulated condensate to be bled from the system. See Figure 1-3, Compressor Pneumatic Air Flow Diagram. There is also a purge valve located under the Pressure Maintaining Valve to purge pressure from the system.

c. Pressure Maintaining Valve. This valve is a fluid pressure regulating valve, it is located downstream of the purification cylinder and is factory set at 2000 psi (138 bar). Air cannot be delivered to the service outlet until the purification cylinder has reached an internal pressure of 2000 psi.

d. Safety Relief Valves. Safety relief valves are installed on each stage of the compressor. Whenever air pressure upstream of each valve exceeds the preset relief pressure, the valve will open and dump air pressure to atmosphere. Once the upstream pressure goes below the safety relief valve pressure setting, the valve will close.

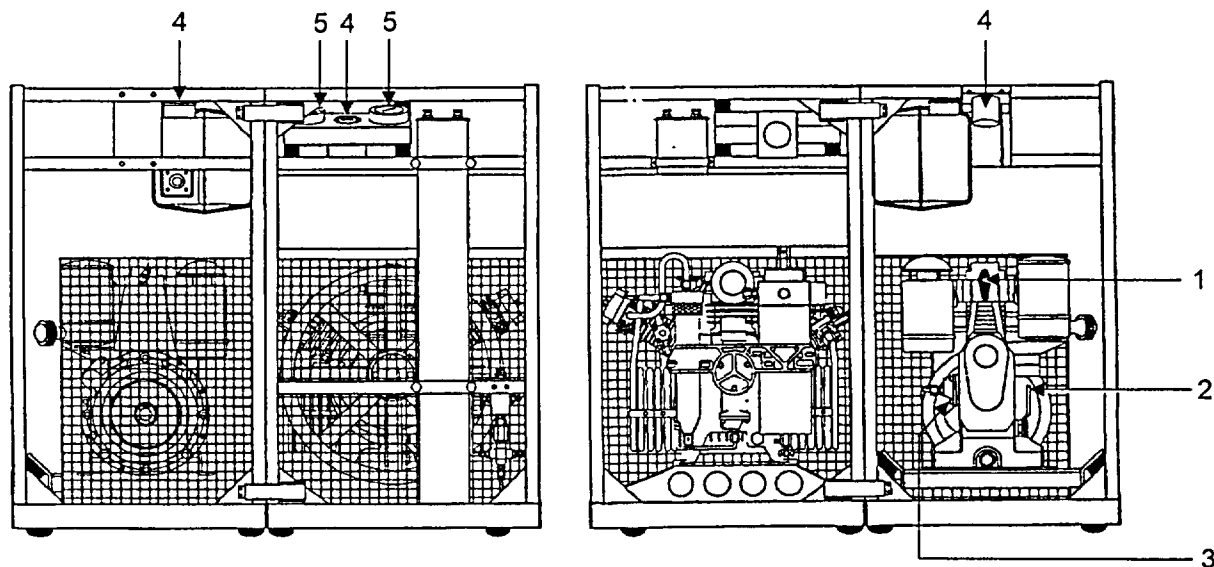

FIGURE 2-1. OPERATOR'S CONTROLS

TABLE 2-1. OPERATOR'S CONTROLS AND INDICATORS

Item	Control or Indicator	Function
1.	Decompression lever	Controls engine decompression. Lever is placed in START position for engine starting and returns to RUN position when engine reaches operating speed. Place decompression lever in FREEWHEEL position when freeing engine of compression to freewheel engine. (Figure 4-3)
2.	Throttle control hand lever	With the hand lever in the START position, the engine is at its highest operating speed. Speed is varied by moving the lever between START and STOP. Engine Operating speed for proper air delivery is full throttle.
3.	Extra Fuel Button	Provides more fuel to the engine during cold starting. Pulling the button out allows more fuel delivery to the engine. Button returns to normal when engine reaches operating speed.
4.	Hourmeters.	An hourmeter is provided for the compressor section and for the engine section. The purpose of the hourmeters is to indicate the number of hours of operation for each unit section.
5.	Pressure gauges.	Pressure gauges are installed in a panel on the air compressor frame. The gauges have a range of 0 to 7500 psi. They read pressure on the inlet and outlet side of the pressure maintaining valve.

Section II. PREVENTIVE MAINTENANCE CHECKS AND SERVICES (PMCS)

Paragraph	Page
2-4 General	2-3
2-5 PMCS Procedures	2-3
2-6 Operator's Preventive Maintenance Checks and Services (PMCS)	2-5

2-4. GENERAL.

a. Before You Operate Always keep in mind the CAUTIONS and WARNINGS. Perform your Before Operation (B) PMCS. Also perform Before Operation (B) PMCS if.

1. You are the assigned operator and have not operated the item since the last weekly PMCS.
2. You are operating the item for the first time.

b. While You Operate. Always keep in mind the CAUTIONS and WARNINGS. Perform your During Operation (D) PMCS

c. After You Operate. Be sure to perform your After Operation (A) PMCS

d. If your Equipment Fails to Operate Troubleshoot with proper equipment. Report any deficiencies using the proper forms, see DA PAM 738-750.

2-5. PMCS PROCEDURES.

a. Table 2-2 lists the PMCS which shall be performed at specified intervals by the operator.

b. Item numbers are assigned to each check or service task. These numbers are to be used as a source of item numbers for the TM NUMBER column on DA Form 2404, Equipment Inspection and Maintenance Worksheet, in recording results of PMCS.

c. The service intervals are divided into three categories, B - Before Operation; D - During Operation; A - After Operation A dot (.) is placed In the interval column for each check or service. If the same check or service is made in two or more intervals, a dot is placed in each applicable column.

d. The ITEM TO BE INSPECTED column lists the item to be checked or serviced

e. The PROCEDURE column describes the procedure by which the check or service is to be performed.

f. The EQUIPMENT IS NOT READY/AVAILABLE IF column contains the basis for classifying the equipment as not ready/available because it is unable to perform its primary mission. An entry in this column will:

1. Identify conditions that make the equipment not ready/available for readiness reporting purposes
2. Deny use of the equipment until corrective maintenance has been performed.

g. The designations left, right, front, and rear as used in the PMCS indicate the side or end of the compressor unit as viewed when facing the compressor flywheel.

h. Leakage definitions for PMCS shall be classified as follows:

Class I. Seepage of fluid (as indicated by wetness or discoloration) not great enough to form drops

Class II. Leakage of fluid great enough to form drops but not enough to cause drops to drip from item being checked/inspected.

Class III. Leakage great enough to form drops that fall from item being checked/inspected.

Equipment operation is allowable with minor leakage (Class I or II). Of course, you must consider the fluid capacity in the item or system being checked/inspected. When In doubt, notify your supervisor.

When operating with Class I or Class II leaks, continue to check fluid levels as required in your PMCS Class III leaks should be reported to your supervisor or unit maintenance shop. Refer to Table 2-2, Operator's Preventive Maintenance Checks and Services

If the equipment must be kept in continuous operation, check and service only those items that can be checked and serviced without disturbing operation. Make the complete checks and services when the equipment can be shut down.

2-6. OPERATOR'S PREVENTIVE MAINTENANCE CHECKS AND SERVICES (PMCS).

The operator's PMCS are shown in Table 2-2, Operator's PMCS.

TABLE 2-2. OPERATOR'S PMCS

NOTE: B=BEFORE OPERATION D=DURING OPERATION A=AFTER OPERATION						
ITEM NO.	Interval			ITEM TO BE INSPECTED	PROCEDURES	EQUIPMENT IS NOT READY/AVAILABLE IF
	B	D	A			
1	•			Reciprocating Compressor Unit	Check entire unit for cleanliness, loose bolts, nuts, and mounting hardware Check clamping devices which secure the two elements together as an operational unit Examine tubes and tube fittings for wear caused by rubbing	Deficiencies are noted
2	•	•	•	Meters and Gauges	Check service line pressure and final pressure gauges for current comparison/calibration label Check all gauges for damaged faces or loose mounting hardware (paragraph 3-17).	Faces, pointers, and lenses are damaged Gauges are out of calibration.
3	•		•	Engine Fuel Tank	Check the fuel supply Ensure the tank is full Check gasket (missing or damaged).	No fuel is available
4	•		•	Engine Oil Level	Check engine oil level, fill to proper level as required (paragraph 3-15)	
5	•			Engine Oil Bath Air Cleaner	Ensure that air cleaner bowl is filled to the 3 holes in the cup before starting the engine Use the same grade of oil as is used in the engine. Service air cleaner after every 120 hours of operation (paragraph 3-15.2.)	Oil level is below the oil level mark
6	•		•	Compressor Oil Level	Check oil level with dipstick. Ensuring the dipstick is screwed in correctly. Fill to proper level (paragraph 3-14.1).	Oil at or below the add line
7		•		Pressure Maintaining Valve (PMV)	Check pressure at the service line outlet on the final pressure gauge. It should be maintained at 2000 psi (138 bar) (paragraph 3-16.1)	PMV does not maintain 2000 psi on the final pressure gauge
8	•			Prefilter and Intake Hose	Check for damage, dirt or debris (paragraph 3-14.3).	Deficiencies are noted
9	•			Fill Hose Assembly	Check gauge and safety relief valve for current comparison/ calibration label Check safety line and fill hose for wear, abrasion or damage (paragraph 3-19)	Faces, pointers, and lenses are damaged Safety valve out of calibration. Wear or damage noted

NOTE: B=BEFORE OPERATION D=DURING OPERATION A=AFTER OPERATION						
ITEM NO.	Interval			ITEM TO BE INSPECTED	PROCEDURES	EQUIPMENT IS NOT READY/AVAILABLE IF
	B	D	A			
10	•			Fuel Lines (Engine)	Inspect fuel lines wear, abrasion, damage or leaks (paragraph 3-15.5). Replace damaged parts, tighten loose fittings and clamps.	
11	•			Fuel Injector (Engine)	Check mounting hardware, ensure injector is securely fastened.	
12		•		Fuel Injector (Engine)	Check for improper operation, indicated by black exhaust smoke. If maintenance of the injector is indicated refer to unit maintenance.	
13	•			Fuel Pump (Engine)	Check for leaks or loose mounting hardware. Operate extra fuel button to ensure ease of operation with no binding or sticking. If faults other than loose fasteners are found refer to Direct Support.	
14	•			Final Oil/Water Separator	Check maintenance record, service the separator every 1000 hours of operation (paragraph 3-16.3).	
15	•			Intermediate Filter	Check maintenance record, service the intermediate filter every 1000 hours of operation (paragraph 3-15.6).	
16	•			Crank Handle	Inspect cranking handle for cracks, distortion or defects. Ensure the handle fits properly in the mating parts of the engine without binding. Replace handle if it is defective.	
17	•			Cooling Fins/Belt Guard	Inspect the fins of the compressor intercoolers and aftercoolers for dust. Inspect the cooling fins of the engine and compressor cylinders and valve heads for dust. Check belt guard screens for obstructions/dust. Clean off dust with brush (Item 8, Appendix E), or with low pressure compressor air (30 psi).	
18	•			Inspect V-Belt Guards	Inspect the belt guard screen fasteners to ensure that each belt guard is securely held in place. Keep belt guards free of obstructions. Replace any damaged belt guards.	

NOTE: B=BEFORE OPERATION D=DURING OPERATION A=AFTER OPERATION

ITEM NO.	Interval			ITEM TO BE INSPECTED	PROCEDURES	EQUIPMENT IS NOT READY/AVAILABLE IF
	B	D	A			
19	•			Engine Exhaust Muffler	Check maintenance record and inspect the engine exhaust muffler every 40 hours, replace if unserviceable (paragraph 3-15.3).	
20	•			Engine Oil	Verify the engine oil has been changed within the last 120 hours of operation (paragraph 3-15.1).	
21	•			Compressor Oil	Verify the compressor oil has been changed within the last 240 hours of operation (paragraph 3-14.1).	
22	•			Purifier Cartridge	Replace the purifier cartridge after every 40 hours of operation (paragraph 3-16.2).	
23	•			Compressor Air Intake Filter	Replace the air cleaner filter element after every 120 hours of operation (paragraph 3-14.3)	
24		•		Oil Pressure Regulator	Check oil pressure setting, adjust if necessary, (oil pressure should be 850 psi) (paragraph 3-14.1)	
25	•			Throttle Control Hand Lever	Check for movement (paragraph 3-15.4)	

Section III. OPERATION UNDER USUAL CONDITIONS

Paragraph		Page
2-7	Assembly and Preparation for Use	2-7
2-8	Pre-Operational Checks	2-8
2-9	Start-Up Procedures	2-9
2-10	Shutdown Procedures	2-10
2-11	Preparation for Movement	2-10
2-12	Decals and Instruction Plates	2-11

2-7. ASSEMBLY AND PREPARATION FOR USE.

Before starting the engine, ensure that the person has the necessary qualifications and training, and is aware of all safety precautions and regulations that must be observed.

WARNING

To PREVENT INJURY, ENSURE THAT WORK CLOTHES ARE CLOSELY FITTING SO THAT THEY CANNOT BE CAUGHT IN ROTATING MACHINERY OR PROJECTING PARTS.

a. Inspection. Inspect the unit for damage. Report all discrepancies in accordance with DA PAM 738-750

b. Preparation. Remove the tarpaulin or protective cover from the unit. Verify that the assembly clamping devices are in place and in good condition. Insert the filter cartridge into the purification cylinder. (paragraph 3-16.2). Ensure that pipes, hoses and connections are securely in place. Place the compressor and engine units in the proper position for assembly by aligning the V-belt grooves in the engine and compressor pulleys. When the sections are aligned use the draw latches to clamp the units together (Figure 1-1 and 1-2).

1. Make sure all draw latches holding the two units together are securely in place in the fully locked-down position. (Figure 1-1 and Figure 1-2).

2. Remove the engine unit V-belt guard by unbolting seven bolts and lifting belt guard from frame.

3. Set decompression lever to FREEWHEEL position. (Figure 4-3)

WARNING

TO AVOID PERSONAL INJURY, AVOID TRAPPING FINGERS BETWEEN V-BELT AND PULLEY WHILE INSTALLING V-BELT.

4. Ensure V-belt is in compressor pulley groove, then place V-belt in groove on top of engine pulley, and Insert flat of screwdriver between belt and sheave at 2700 position. Keeping screwdriver perpendicular to sheave rotate left (ccw) until belt seats in sheave groove.

5. Reinstall the engine unit V- belt guard.

c. Location The site location must be free of contaminated air. A sufficient supply of fresh air for properly cooling the units must be available. The unit must be located at least 20 inches away from any wall and away from other machinery for proper cooling The combined compressor unit should be placed on a firm, level surface. Under no circumstance should the compressor be operated if tilted more than 15 degrees in any direction.

WARNING

TO ENSURE AS LITTLE AIR CONTAMINATION AS POSSIBLE, THE INTAKE HOSE MUST BE FULLY EXTENDED AND ALWAYS BE LOCATED UPWIND OF THE ENGINE EXHAUST. WHEN THE WIND CHANGES, THE COMPRESSOR AIR INTAKE MUST BE RELOCATED. THIS ACTION IS IMPERATIVE TO ENSURE THAT AS LITTLE CONTAMINATED AIR AS POSSIBLE ENTERS THE COMPRESSOR.

2-8. PRE-OPERATIONAL CHECKS.

a. Ensure the compressor intake hose is fully extended and located upwind of the engine exhaust.

b. Check oil level in compressor (paragraph 3-5.4).

- c. Check engine fuel tank (Table 2-2, Item 3)
- d. Check engine oil level (paragraph 3-4)
- e. Ensure the engine oil bath air cleaner has been filled (Table 2-2, Item 5).
- f. Check records to determine if the purification cartridge life has been exceeded.

2-9. START-UP PROCEDURES.

WARNING

CARBON MONOXIDE (EXHAUST GAS) CAN KILL YOU. EXPOSURE TO EXHAUST GASES PRODUCES SYMPTOMS OF HEADACHE, DIZZINESS, LOSS OF MUSCULAR CONTROL, DROWSINESS, OR COMA. BRAIN DAMAGE OR DEATH CAN RESULT FROM SEVERE EXPOSURE. FUMES FROM THE ENGINE BECOME CONCENTRATED WITH POOR VENTILATION. OPERATE ENGINE IN A VENTILATED AREA ONLY. IF SOMEONE IS EXPOSED TO CARBON MONOXIDE FUMES, IMMEDIATELY TAKE PERSONNEL TO FRESH AIR; KEEP WARM AND STILL; GIVE ARTIFICIAL RESPIRATION IF NEEDED. SEEK MEDICAL ATTENTION. ADMINISTER OXYGEN, IF AVAILABLE. GOOD VENTILATION IS THE BEST DEFENSE AGAINST EXHAUST POISONING.

a. General.

1. Unit must be operated at full speed (throttle lever must be at full throttle).
2. Intake hose must be fully extended with hose end upwind from engine exhaust.
3. Open condensate drain valves every 15 - 20 minutes during operation
4. Perform all maintenance schedule items at their Indicated intervals
5. Install hourmeters in HOURMETER ON positions for operation.
6. Install hourmeters In HOURMETER OFF positions for transportation.

b. Normal Start.

1. Open manual condensate drain valves.
2. Set throttle lever to full speed
3. Turn decompression lever to the START position. (Fig. 4-3)
4. Insert crank handle.
5. Make sure that compression is on the upstroke of the crank handle
6. Turn crank handle with increasing speed.
7. Pull crank handle out of engine as engine starts
8. Close manual condensate drain valves

c. Emergency Start in Cold Weather. Refer to paragraph 2-13 c.1 through 2-13 c.6

2-10. SHUTDOWN PROCEDURES.**CAUTION**

Immediate shutdown of the engine without a 5 minute idle may cause damage. Do so only when made necessary by overriding system requirements or emergency conditions.

- a. Allow engine to idle for 5 minutes to allow engine operating temperature to stabilize
- b. Move throttle control hand lever to STOP position as indicated on the crankcase.
- c. Open manual drain valves. Drain condensate from the oil/water separators.

2-11. PREPARATION FOR MOVEMENT.

- a. Purge service line pressure.
- b. Secure air intake hose in compressor side hose tray.
- c. Close and secure all valves.
- d. Secure engine crank handle to frame.
- e. Disconnect filling hose and secure it in compressor side hose tray.
- f. Unbolt and remove the engine unit V-belt guard.
- g. Set decompression lever to FREEWHEEL position. (Fig. 4-3)

WARNING

TO AVOID PERSONAL INJURY, AVOID TRAPPING FINGERS BETWEEN V-BELT AND PULLEY WHILE REMOVING V-BELT.

- h. Place flat of screwdriver at bottom of pulley between V-belt and pulley. Move screwdriver to 45° to lever belt out of line with pulley. Rotate sheave right (cw) until belt is fully disengaged from pulley groove.
- i. Replace engine unit V-belt guard
- j. Cover air intakes for engine and compressor. Cover exhaust outlet.
- k. Secure the hourmeters in the HOURMETER OFF position in compressor/engine HOURMETER panels to prevent hourmeters from recording travel time. (paragraph 3-17 B).
- l. If necessary, separate Reciprocating Compressor Unit into portable sections by releasing the draw latches and pulling Reciprocating Compressor Unit into two separate sections.
- m. If Reciprocating Compressor Unit is remaining unseparated, cover combined compressor/engine unit with tarpaulin cover.

2-12. DECALS AND INSTRUCTION PLATES

The following decals and instruction plates are attached to the frame of the unit All are self explanatory. If there are differences between this document and the decals or instruction plates, the procedures in this manual take precedence

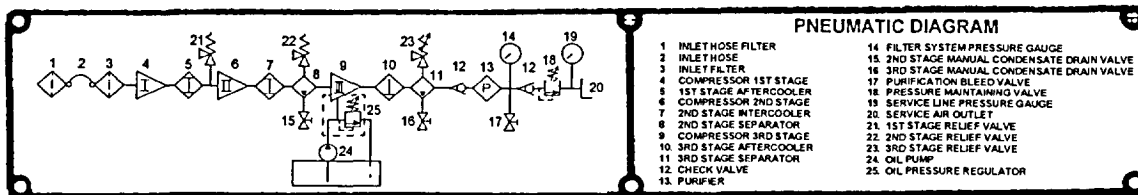
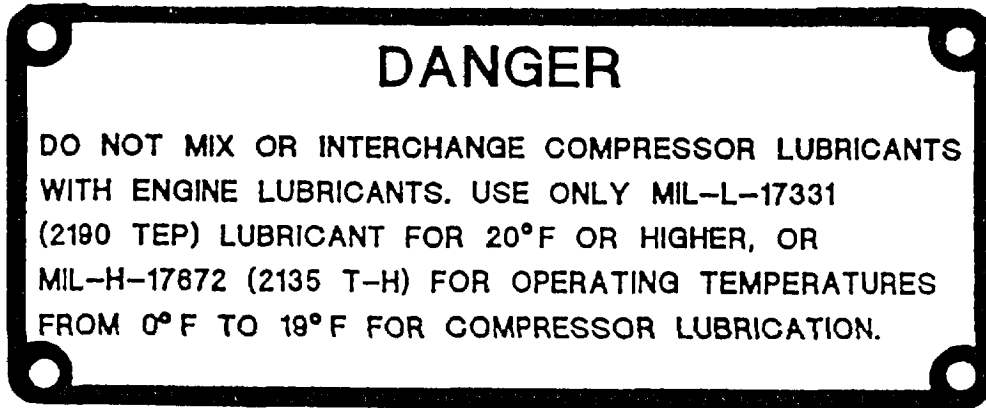
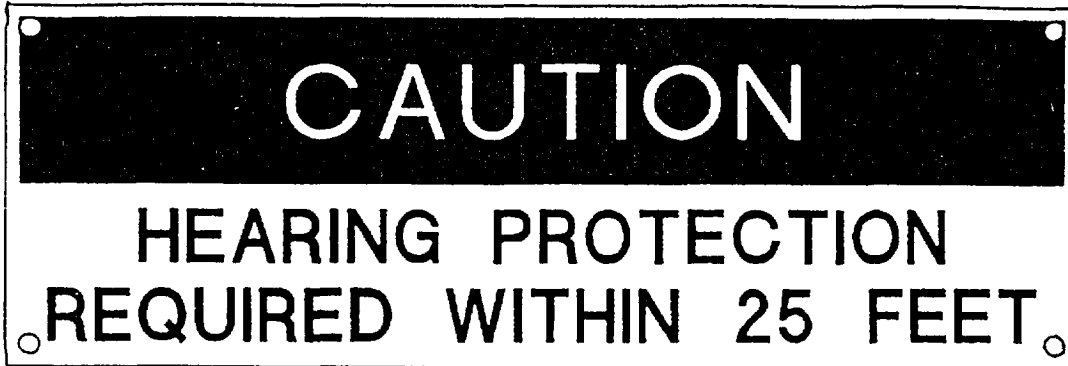

2-12. DECALS AND INSTRUCTION PLATES (Continued).

COMPRESSOR UNIT, BREATHING AIR, 5 CFM
3200 PSI, W/DIESEL ENGINE, 6 HP
MODEL: CAPITANO-PD
BAUER COMPRESSORS, INC.
NORFOLK, VIRGINIA, U.S.A.
SERIAL NO. 18782-C [REDACTED]
NSN: 4310-01-330-6549
[REDACTED]
DES. ACT. 57328 MFG. 57328 [REDACTED]
DATE OF MANUFACTURE: SEPTEMBER 1995
CONTRACT NO. DAAK01-90-C-0227
U.S.

○ HOURMETER ON ○

○ HOURMETER OFF ○

○ SERVICE
OUTLET ○

○ DIESEL FUEL
ONLY ○

○ FILTER SYSTEM PRESSURE HOURMETER ON SERVICE LINE PRESSURE ○

DANGER
THE CARTRIDGE IN THIS CYLINDER
MUST BE REPLACED NO LATER THAN
EVERY 40 OPERATING HOURS. CARTRIDGE
PART NO. 57328-068416.

2-12. DECALS AND INSTRUCTION PLATES (Continued).

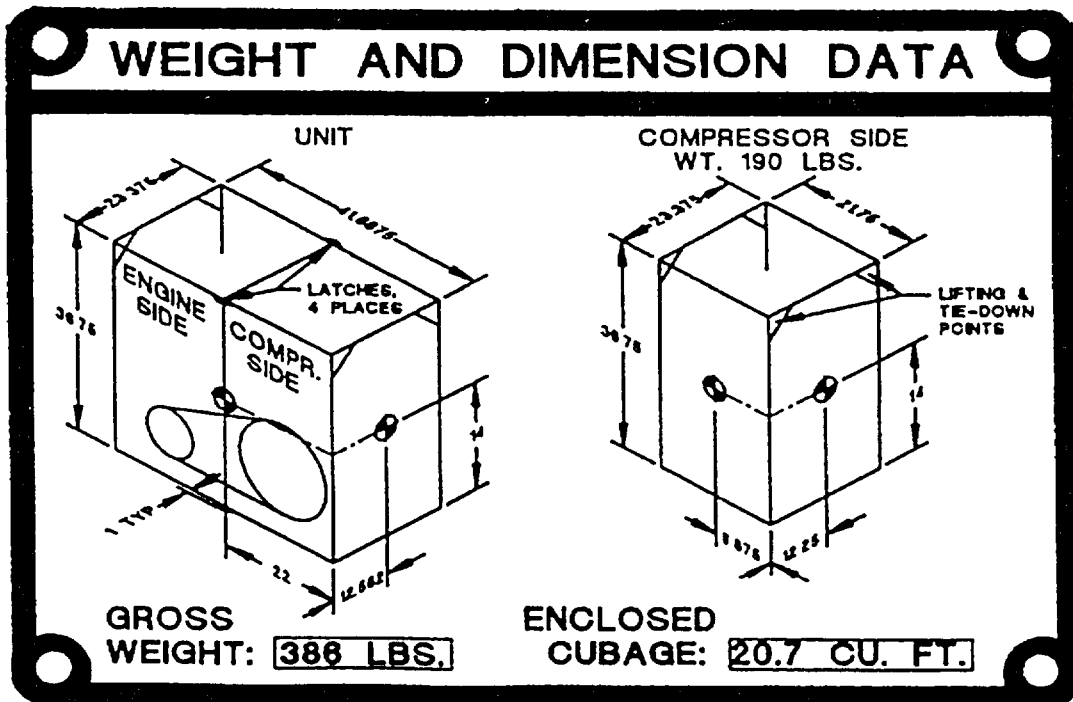
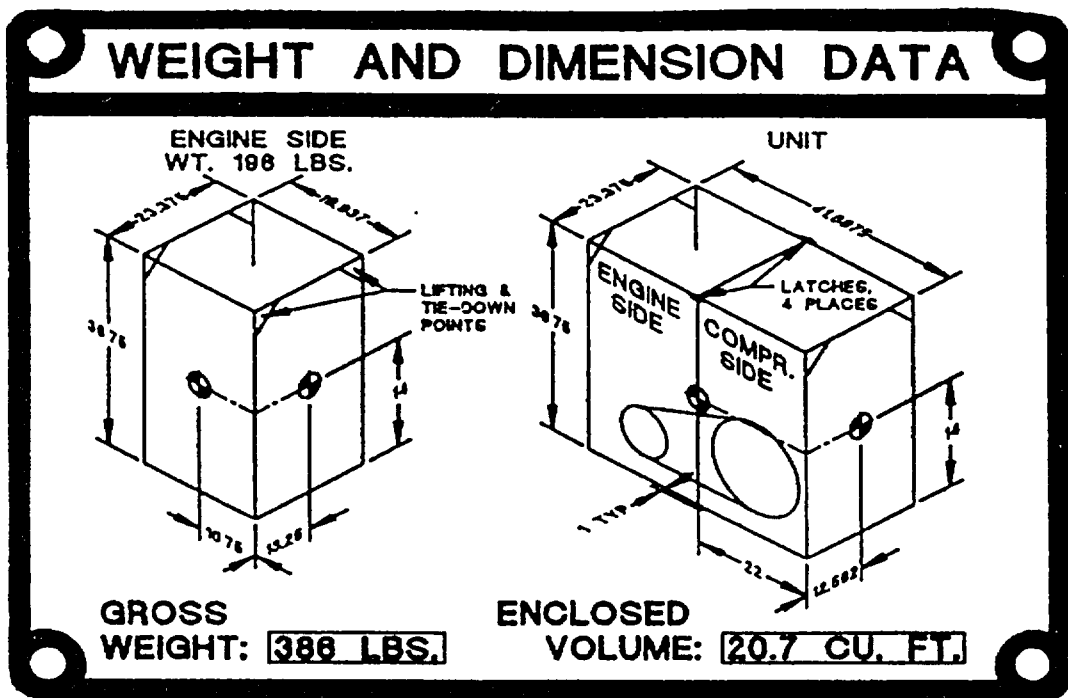

2-12. DECALS AND INSTRUCTION PLATES (Continued).

OPERATING INSTRUCTIONS

GENERAL

1. UNIT MUST BE OPERATED AT FULL SPEED (THROTTLE LEVER MUST BE AT FULL THROTTLE).
2. INLET HOSE MUST BE FULLY EXTENDED WITH HOSE END UP—WIND FROM THE ENGINE EXHAUST.
3. OPEN CONDENSATE DRAIN VALVES EVERY 15 MINUTES DURING OPERATION.
4. PERFORM ALL MAINTENANCE SCHEDULE ITEMS AT THEIR INDICATED INTERVALS.
5. INSTALL HOURMETERS IN HOURMETER ON POSITION FOR OPERATION.
6. INSTALL HOURMETERS IN HOURMETER OFF POSITION FOR TRANSPORT.

NORMAL START

1. OPEN MANUAL CONDENSATE DRAIN VALVES.
2. SET THROTTLE LEVER TO FULL SPEED.
3. TURN DECOMPRESSION LEVER TO THE VERTICAL POSITION.
4. INSERT CRANK HANDLE, MAKING SURE THAT COMPRESSION IS ON THE UP-STROKE OF CRANK HANDLE.

5. TURN CRANK HANDLE WITH INCREASING SPEED
6. PULL CRANK HANDLE OUT OF ENGINE AS ENGINE STARTS.
7. CLOSE MANUAL DRAIN VALVES.

EMERGENCY START IN COLD WEATHER

1. REMOVE ENGINE BELT GUARD COVER AND REMOVE BELT FROM ENGINE SHEAVE.
2. PULL UP ON EXTRA FUEL SWITCH.
3. FILL OIL PRIMING DEVICE AT TOP OF CYLINDER HEAD WITH CRANKCASE OIL AND REPLACE CAP. (NOTE: DO NOT PRIME MORE THAN 2 TIMES CONSECUTIVELY).
4. FOLLOW NORMAL START PROCEDURE AND RUN THE ENGINE FOR 10 MINUTES.
5. REATTACH BELT TO ENGINE SHEAVE AND REINSTALL ENGINE BELT GUARD COVER.
6. FOLLOW NORMAL START PROCEDURE.

STOPPING THE UNIT

1. MOVE THROTTLE LEVER TO THE STOP POSITION.
2. OPEN MANUAL CONDENSATE DRAIN VALVES.

<u>TIME INTERVAL</u>	<u>REQUIRED MAINTENANCE</u>
DAILY (OR BEFORE EACH USE)	<ul style="list-style-type: none"> • CHECK ENGINE OIL LEVEL. • CHECK COMPRESSOR OIL LEVEL.
AFTER FIRST 20 HOURS	<ul style="list-style-type: none"> • FIRST ENGINE OIL CHANGE. • FIRST COMPRESSOR OIL CHANGE, CHECK OIL PRESSURE. • CHECK ENGINE VALVE TAPPET CLEARANCE.
EVERY 20 HOURS	<ul style="list-style-type: none"> • TIGHTEN ANY LOOSE FASTENERS AND CHECK FITTINGS FOR LEAKS. • CHECK ENGINE AIR CLEANER FOR EXCESSIVE MUD OR LOW OIL MAINTENANCE IF NECESSARY. • CHECK COMPRESSOR AIR INLET FILTER, CLEAN OR REPLACE AS NEEDED. • IN EXTREMELY DUSTY CONDITIONS, REMOVE AND CLEAN ENGINE AIR CLEANER INSERT.
EVERY 40 HOURS	<ul style="list-style-type: none"> • REPLACE PURIFICATION CARTRIDGE. • CLEAN SPARK ARRESTOR AND MUFFLER.
EVERY 120 HOURS	<ul style="list-style-type: none"> • CHANGE ENGINE OIL. • SERVICE ENGINE AIR CLEANER. • CHECK ENGINE VALVE TAPPET CLEARANCE. • REPLACE COMPRESSOR AIR INLET FILTER. • CHECK DRIVE BELT TENSION AND WEAR, ADJUST OR REPLACE WHEN NEEDED. • CLEAN ENGINE COOLING FINS. • CLEAN ENGINE AND COMPRESSOR COOLING FINS.
EVERY 240 HOURS	<ul style="list-style-type: none"> • CHANGE COMPRESSOR OIL, CHECK OIL PRESSURE.
EVERY 480 HOURS	<ul style="list-style-type: none"> • CHANGE ENGINE FUEL FILTER
EVERY 1000 HOURS	<ul style="list-style-type: none"> • REPLACE VALVES ON COMPRESSOR. • CLEAN SINTERED METAL FILTER ELEMENT IN INTERFILER.

Section IV. OPERATION UNDER UNUSUAL CONDITIONS

Paragraph		Page
2-13	Operation in Extreme Cold.....	2-16
2-14	Operation in Extreme Heat	2-16
2-15	Operation in Dusty or Sandy Areas	2-16
2-16	Operation in Rainy or High Humidity Conditions	2-16
2-17	Operation in Salt Water Areas	2-16
2-18	Operation at High Altitude.....	2-16

2-13. OPERATION IN EXTREME COLD.

- a. Use proper engine and compressor oil for cold weather. See lubricants in paragraph 3-6

WARNING

DEATH OR SERIOUS INJURY COULD OCCUR IF FUEL IS NOT HANDLED CAREFULLY. USE IN A WELL VENTILATED AREA AWAY FROM OPEN FLAME, ARCING EQUIPMENT, IGNITION SOURCES, HEATERS, OR EXCESSIVE HEAT. ENGINE MUST BE TURNED OFF AND COOL BEFORE REFUELING. USE PROPER REFUELING PROCEDURES AND EQUIPMENT TO AVOID SPILLAGE. DO NOT RUN ENGINE NEAR OPEN FUEL CONTAINERS.

DO NOT SMOKE.

- b. Keep fuel tank full to prevent condensation. Condensation can freeze and clog fuel lines, filters, and injectors

- c. Cold Weather Starting.

1. Remove engine belt guard cover and remove belt from engine pulley.
2. Pull out on extra fuel button.
3. Fill cold start aid device at top of cylinder head with crankcase oil and replace cap (Note: Do not prime more than two times consecutively)

than two times consecutively)

CAUTION

ENGINE LOCKUP COULD OCCUR IF OIL IS Poured INTO CENTER OF COLD START ASSIST. TAKE CARE TO FILL COLD START ASSIST CUP FROM THE SIDE.

4. Follow normal start procedures and allow engine to run for 10 minutes. Stop engine
5. Reattach belt to engine pulley and reinstall engine belt guard cover.
6. Follow normal start procedures (paragraph 2-9, step b).

2-14. OPERATION IN EXTREME HEAT.

The engine and compressor are air cooled Heat can be removed from those units in three ways engine exhaust, lubrication oil, and the passage of air across and through cylinder fins and cooler coils When operating In high ambient temperatures, observe the following.

- a. With engine stopped, inspect frequently to be sure that cylinder cooling fins are clean and free of dirt. Dirt inhibits cooling

- b. With engine stopped, inspect frequently to be sure that engine and compressor lubricating oil levels are at the top mark on dipsticks. Add oil if necessary to bring oil levels up to the full mark.
- c. Follow unit maintenance procedures In Chapter 4. Refer to Table 4-1, Unit PMCS.

2-15. OPERATION IN DUSTY OR SANDY AREAS.

- a. During refueling and PMCS, be sure that sand or dust is not allowed to enter fuel or lubricating system.
- b. Perform maintenance schedule on engine oil bath air cleaner. (paragraph 3-15 A)
- c. With engine stopped, inspect frequently to be sure that cooling fins are clean and free of dirt. Dirt inhibits cooling.
- d. With engine stopped, inspect frequently to be sure that engine oil is to top mark on dipstick. Add oil as necessary.
- e. Be sure that the frequency of PMCS is increased In accordance with local condition requirements.

2-16. OPERATION IN RAINY OR HIGH HUMIDITY CONDITIONS.

- a. Check that fuel tank cap is tight. Fill tank immediately after every operating period to prevent condensation.
- b. Drain condensate separators every 10-15 minutes.

2-17. OPERATION IN SALT WATER AREAS.

- a. Avoid any direct contact with salt water to prevent corrosion. If salt water does come in contact with the unit, rinse the unit with clean, fresh water.
- b. Repair any paint damage, such as cracks and chips. Apply standard rustproofing material to all exposed ferrous (steel) surfaces. If rustproofing material is not available, apply a light film of oil or grease to all exposed metal surfaces.

2-18. OPERATION AT HIGH ALTITUDE.

- a. Engine power output will decrease by about 3 /percent for every 1000 feet of altitude above sea level. The compressor will have a similar loss of operating efficiency.
- b. Service the engine/compressor air cleaner filters often to minimize this loss of efficiency.

CHAPTER 3

OPERATOR MAINTENANCE INSTRUCTIONS

		Page
Section I	Lubrication Instructions	3-1
Section II	Service Upon Receipt of Material	3-7
Section III	Troubleshooting Procedures	3-9
Section IV	Operator Maintenance Procedures.....	3-14

Section I. LUBRICATION INSTRUCTIONS

Paragraph		Page
3-1	General	3-1
3-2	Oil Viscosity	3-1
3-3	Lubrication of Engine	3-1
3-4	Filling/Checking Engine Oil	3-2
3-5	Lubrication of Compressor	3-3
3-6	Oil Capacities/Specifications	3-5
3-7	Maintenance on a New Engine and Compressor.....	3-5

3-1. GENERAL.

The objective of this section is to present the operator with engine and compressor lubrication instructions. Proper lubrication is essential to operating life of any machine. Always check oil levels of both the engine and compressor before starting either unit.

3-2. OIL VISCOSITY.

The viscosity of oil is greatly influenced by ambient temperatures at the site of operation. Figure 3-1 shows the viscosity of oil recommended for use in the model CAPITANO-PD. When ambient temperatures fall below the limit of the oil selected, the starting performance of the compressor unit will be affected, but no equipment damage will be caused. Since a too viscous oil can cause starting difficulties, the choice of viscosity grades during winter operation should be governed by the ambient temperature prevailing at the time of engine starting. Oil changes resulting from ambient temperature changes can be avoided by using multigrade oils. All viscosities are subject to oil change intervals recommended in Table 2-2.

3-3. LUBRICATION OF ENGINE.

The engine is splash lubricated. A scooper, incorporated into the connecting rod cap, forces oil through drilled passages to lubricate the cylinder and connecting rod bearings.

3-3.1. ENGINE OIL CHANGE.

The engine oil should be changed regularly according to the PMCS schedule (Table 2-2)

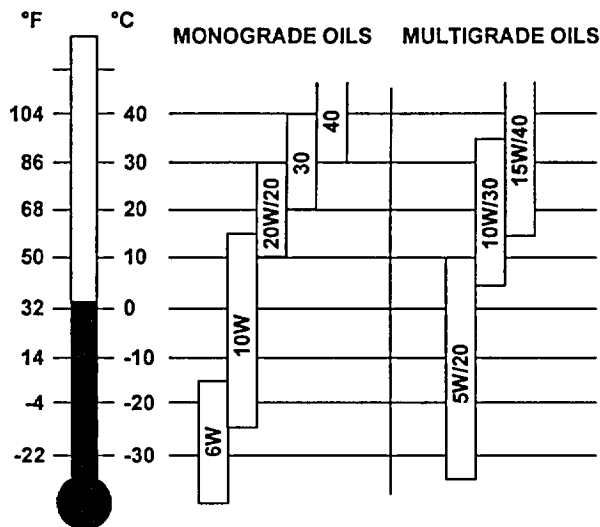

Figure 3-1. Recommended Viscosities

3-3.2. ENGINE OIL CHANGE PROCEDURE.

Refer to figure 3-4 and proceed as follows:

NOTE

ENGINE SHOULD BE IN A LEVEL POSITION.

- a. Run the engine until it reaches operating temperature.

WARNING

ALLOW ENGINE TO COME TO A COMPLETE STANDSTILL. AVOID CONTACT WITH HOT OIL, EXPOSURE MAY RESULT IN SCALDING OR OTHER INJURIES.

- b. Place a suitable oil drain pan beneath the engine oil drain plug.
- c. Remove the oil drain plug from the engine
- d. Allow the warm oil to totally drain.
- e. Clean the magnet on the oil drain plug of accumulated dirt.
- f. Reinstall the oil drain plug
- g. Remove the oil drain pan Dispose of the used oil in accordance with current instructions for waste oil disposal
- h. Remove the engine oil fill cap (3) Figure 3-2.
- i. Fill with 1.1 quarts (1 liter) of correct grade and viscosity oil by pouring it slowly into the filler neck. Wait five minutes after filling, check oil level (paragraph 3-4), reinstall the filler cap.

CAUTION

DO NOT MIX TYPE OR VISCOSITY GRADES OF OIL. DO NOT OVERFILL. ENGINE DAMAGE MAY RESULT.

3-4. FILLING/CHECKING ENGINE OIL.

Fill engine crankcase and check oil level in accordance with maintenance schedule (paragraph 3-15).

CAUTION

DO NOT MIX TYPE OR VISCOSITY GRADES OF OIL. DO NOT OVERFILL. ENGINE DAMAGE MAY RESULT.

- a. With engine level, check oil level. Remove oil dipstick (Figure 3-2, Item 1) and wipe with a lint free cloth. Insert oil dipstick all the way into engine Withdraw dipstick. Engine oil should coat dipstick to top mark (2) (max.).

- b. If oil coating is below top mark, remove oil cap (3) and fill with oil of proper viscosity as required.
- c. Select an oil viscosity grade to suit ambient temperature using Figure 3-1.
- d. After adding oil, check oil level again to be sure oil coats dipstick to top mark.

e. If oil coating extends above the top mark, loosen drain plug (Figure 1-2, Item 6) and drain enough oil to lower the oil level to top mark on dipstick then tighten drain plug securely The drain plug is located in the base of the engine opposite the flywheel, below the crankshaft.

f. When the procedure is complete, ensure that oil cap (3) is securely replaced.

3-5. LUBRICATION OF COMPRESSOR.

The third stage is force lubricated by a pump (Figure 3-3, Item 1) operated by a cam of the crankshaft The oil pressure regulator valve (2) maintains the proper working pressure Any oil not needed by the third stage is returned to the crankcase through the feedback tube (3). Other moving parts of the compressor are lubricated with oil splashed by the crankshaft Cylinders of the first and second stages receive additional lubrication from oil vapors from the crankcase vent feedback line (4).

3-5.1. Operation Under Severe Conditions.

For operation under severe operating conditions such as continuous running and/or high ambient temperatures, the use of synthetic compressor oil is recommended. This oil can also be used under normal conditions. See paragraph 3-6 for oil specifications

3-5.2. Compressor Oil Level Check.

Check the oil level before starting the compressor. To check the oil level, vent any residual pressure from the system by opening and then closing the manual drain valves/purge valves on the separators and purification system. Open the filler cap slowly, allowing any residual pressure to vent from the crankcase Remove the cap/dipstick from the oil filler neck. Wipe the dipstick with a lint-free cloth.

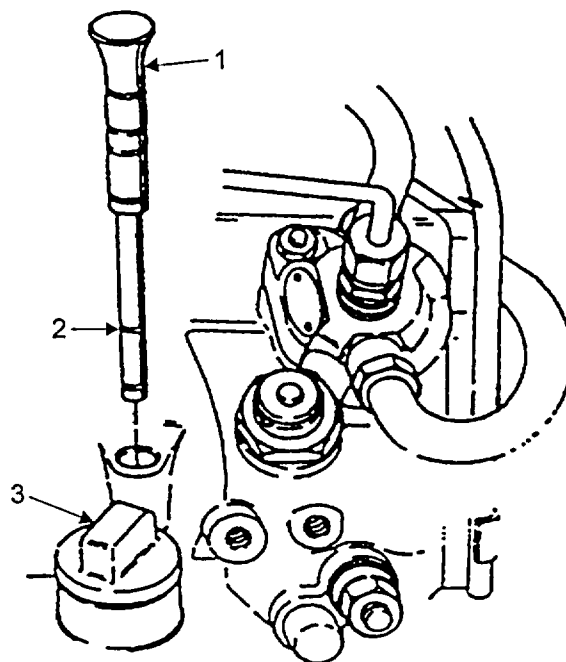

FIGURE 3-2. ENGINE OIL FILL

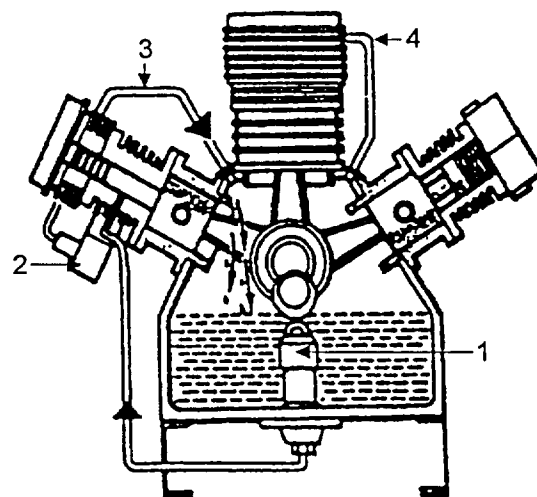

FIGURE 3-3. COMPRESSOR OIL SYSTEM

Return the oil cap/dipstick to the filler neck completely, then remove and note the oil level on the dipstick. Add or drain as necessary. The oil level must not exceed the maximum level mark on the dipstick.

3-5.3. Compressor Oil Change Procedure.

The compressor oil should be changed according to the PMCS schedule (Table 2-2). Refer to Figure 3-4 and proceed as follows:

- a. Run the compressor unit until it is warm. Turn off the compressor.

CAUTION

THE FEDERAL WATER POLLUTION CONTROL ACT PROHIBITS THE DISCHARGE OF OIL OR OILY WASTE INTO OR UPON THE NAVIGABLE WATERS OF THE UNITED STATES OR THE WATERS OF THE CONTIGUOUS ZONE, IF THE DISCHARGE CAUSES A FILM OR DISCOLORATION OF THE SURFACE OF THE WATER OR CAUSES A SLUDGE OR EMULSION BENEATH THE SURFACE OF THE WATER. ENSURE A CONTAINER OF SUFFICIENT SIZE IS USED WHEN DRAINING THE OIL.

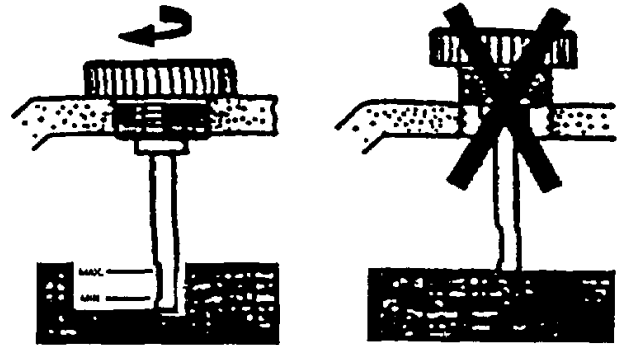

Figure 3-4. Compressor Oil Level

- b. Vent any residual pressure from the system by opening and then closing the manual drain valves on oil/water separators and purge valve of the purification system.

1. Open the oil filter cap/dipstick slowly, allowing any residual pressure to vent from the crankcase.
2. Remove the oil filter cap/dipstick from the oil filler neck.
3. Place a suitable oil drain pan beneath the drain plug at the back of the unit.
4. Remove the oil drain plug from the compressor, (Figure 3-5, item 3).
5. Allow the warm oil to totally drain.
6. Reinstall the oil drain plug.
7. Remove the oil drain pan. Dispose of the used oil in accordance with current instructions for waste oil disposal.

CAUTION

TO AVOID DAMAGE TO THE COMPRESSOR, DO NOT MIX TYPE OR VISCOSITY GRADES OF OIL. DO NOT OVERFILL.

- c. To fill with oil, pour 1.5 quarts of oil slowly into the oil filler neck. If necessary, add oil. Wait five (5) minutes after filling, check oil level per paragraph 3-5.2, reinstall the filler cap, then start the compressor unit.

- d. Check the operation of the oil pump It is working properly if no bubbles are visible in the oil pressure regulating valve sight glass (See figure 3-6, item 3)
- e. Vent the pump if bubbles are visible, (paragraph 3-5.4)

3-5.4. Venting the Compressor Oil Pump.

If bubbles are visible in the oil pressure regulating valve sight glass, especially after maintenance or repair work, venting the oil pump will be necessary. Refer to Figure 3-5 and proceed as follows:

- a. With the compressor shut off, and the crankcase vented, slowly loosen the tube nut (2) Turn the compressor by hand until bubble-free oil emerges from the fitting This should only take a few seconds.

- b. Tighten the tube nut (2)

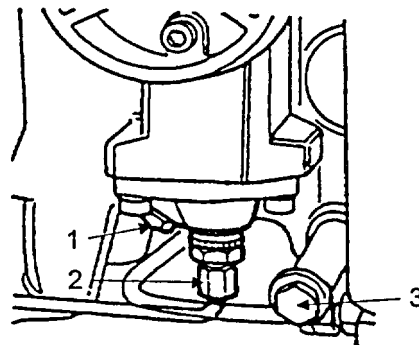

FIGURE 3-5. VENTING THE OIL PUMP

3-5.5. Compressor Oil Pressure Regulator.

- a. Remove cap nut (Figure 3-6, Item 1) to expose setscrew (2).

- b. Remove the tube plug (4)

- c. Connect a calibrated oil pressure gauge, 0-1500 psi, to the oil pressure regulator test connector (4) to read oil pressure

- d. Start compressor.

- e. Using a screwdriver, turn setscrew (2) in oil pressure regulator (5) to adjust oil pressure

- f. Turn the setscrew clockwise to increase pressure, counterclockwise to decrease pressure.

- g. Oil pressure should be 850 psi +/- 50 psi

- h. If bubbles are observed in the regulator site glass (3) on the oil pressure regulator, it is necessary to vent the pump, refer to paragraph 3-5.4.

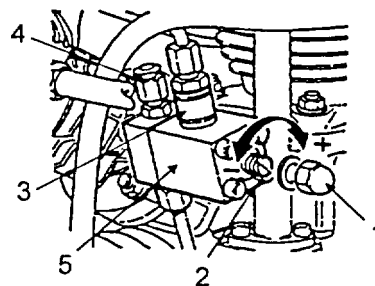

FIGURE 3-6. COMPRESSOR OIL PRESSURE REGULATOR

3-6. OIL CAPACITIES/SPECIFICATIONS.

Oil capacities of the separate units are:

Engine	1.16 qt (1.10 l)
Compressor	1.50 qt (1.42 l)

Oil specifications are:

Engine	MIL-L-2104
Compressor	MIL-L-17331 (Normal temperature, 2190TEP)
	MIL-L-17262 (Arctic temperature, 2135TH)

3-7. MAINTENANCE ON A NEW ENGINE AND COMPRESSOR.

a. Engine.

After the first 20 hours of operation:

1. Change oil.
2. Clean oil bath air cleaner.
3. Retighten engine mounting bolts
4. Check connections of air intake and exhaust for tightness.
5. Check V-belt tension.
6. Check engine valve tappet clearance. (Paragraph 4-13.2)

b. Compressor.

After the first 20 hours of operation

1. Change the oil.
2. Leak test all fittings with nonionic detergent solution.

Section II. SERVICE UPON RECEIPT OF MATERIALS

Paragraph	Page
3-8 Scope	3-7
3-9 Site and Shelter Requirements	3-7
3-10 Unpacking Instruction.....	3-7
3-11 Checking Unpacked Equipment	3-7
3-12 Preliminary Service and Adjustment	3-7

3-8. SCOPE.

The section covers information required by organization unit maintenance personnel to ensure the equipment will be adequately inspected, serviced, and operationally tested before it is subjected to normal use. These procedures include site and shelter requirements, service upon receipt of material, and preliminary servicing and adjustment

3-9. SITE AND SHELTER REQUIREMENTS.

WARNING

TO ENSURE AS LITTLE AIR CONTAMINATION AS POSSIBLE, THE INTAKE HOSE MUST BE FULLY EXTENDED AND ALWAYS LOCATED UPWIND OF THE ENGINE EXHAUST. WHEN THE WIND CHANGES, THE COMPRESSOR AIR INTAKE MUST BE RELOCATED. THIS ACTION IS IMPERATIVE TO ENSURE THAT AS LITTLE CONTAMINATED AIR AS POSSIBLE ENTERS THE COMPRESSOR.

The usage site for the compressor should be selected so as to avoid excessive dust, mud, rain, snow, heat, or cold. The compressor must be kept as level as possible. The compressor must never be operated if it is tilted at an angle in excess of 15 degrees in any direction. The unit should be mounted on a hard, flat surface from which all gravel, dirt, or other loose substances have been removed. Avoid the possibility of pickup of trash, stones and so forth by the rapidly rotating flywheels and V-belt. Ensure all loose trash is removed from the area of the compressor to prevent refuse from entering the cooling air inlets. Ensure compressor is not operated inside closed rooms or buildings. If such operation is mandatory, connect an extension pipe to engine exhaust and pipe exhaust fumes outside. Ensure the compressor is protected from rain, wind, snow, dust, and tropical or desert sun. A temporary shelter should be provided by tarpaulins or other means. The maximum utilization of natural shelter such as trees, hills, and rock formations is highly recommended.

3-10. UNPACKING INSTRUCTIONS.

No specific unpacking instructions are required. Refer to the Depreservation Guide DA Form 2258 packed with each unit.

3-11. CHECKING UNPACKED EQUIPMENT.

- a. Inspect the equipment for damage incurred during shipment. If the equipment has been damaged, report the damage on DD Form 6, Packaging Improvement Report.
- b. Check the equipment against the packing slip to see if the shipment is complete. Report all discrepancies in accordance with the instructions of DA PAM 738-750.

3-12. PRELIMINARY SERVICE AND ADJUSTMENT.

- a. Set up unit in accordance with paragraph 2-7.b.

b. Adjust Drive V-belt Adjust the drive V-belt tension by loosening the engine hold down bolts and sliding the engine toward or away from the compressor as needed to allow $\frac{1}{2}$ inch slack in the belt when depressed at the center distance between the engine and compressor. Retighten engine hold-down bolts.

c. Check engine crankcase oil level (paragraph 3-4).

d. Check compressor crankcase oil level (paragraph 3-5.2).

WARNING

DEATH OR SERIOUS INJURY COULD OCCUR IF FUEL IS NOT HANDLED CAREFULLY. USE IN A WELL VENTILATED AREA AWAY FROM OPEN FLAME, ARCING EQUIPMENT, IGNITION SOURCES, HEATERS OR EXCESSIVE HEAT. ENGINE MUST BE TURNED OFF AND COOL BEFORE REFUELING. USE PROPER REFUELING PROCEDURES AND EQUIPMENT TO AVOID SPILLAGE. DO NOT RUN ENGINE NEAR OPEN FUEL CONTAINERS. DO NOT SMOKE.

e. Check fuel level. Add diesel fuel if needed.

Section III. TROUBLESHOOTING PROCEDURES

Paragraph	Page
3-13 General	3-9

3-13. GENERAL.

a. This section provides information for identifying and correcting malfunctions which may develop while operating your Reciprocating Compressor Unit.

b. Before performing troubleshooting, read and follow all safety instructions found in the Warning Summary at the front of this manual

c. This section cannot list all malfunctions/symptoms that may occur, nor all probable causes and corrective actions. If a malfunction/symptom is not listed, or is not corrected by the listed corrective actions, notify your supervisor. There are other malfunctions/symptoms that may occur to the Reciprocating Compressor Unit listed in Table 4-2. These are related to topics that may be found by unit maintenance personnel.

d. When troubleshooting a malfunction/symptom:

(1) Find the troubleshooting procedure for the malfunction in question in Table 3-1. Headings at top of each page show how each troubleshooting procedure is organized. MALFUNCTION/SYMPTOM, PROBABLE CAUSE (in step number order), and TEST OR INSPECTION/CORRECTIVE ACTION.

(2) Perform in the order listed until the malfunction is corrected. DO NOT perform any maintenance task unless the troubleshooting procedure tells you to do so

e. The columns in Table 3-1 are defined as follows:

1. **MALFUNCTION.** A visual or operational indication that something is wrong with the Reciprocating Compressor Unit.

2. **PROBABLE CAUSE** A procedure that isolates the problem in a component or assembly.

3. **TEST OR INSPECTION/CORRECTIVE ACTION** A procedure to correct the problem

TABLE 3-1. OPERATOR/CREW TROUBLESHOOTING PROCEDURES.

MALFUNCTION/SYMPTOM	PROBABLE CAUSE	TEST OR INSPECTION/CORRECTIVE ACTION
---------------------	----------------	--------------------------------------

ENGINE

1. ENGINE HARD TO CRANK.

Compressor loaded.

Open drain/purge valves to unload the compressor.

Oil viscosity too high.

Refer to Figure 3-1.

2. ENGINE WILL NOT START.

Fuel supply.

Check fuel tank for fuel available. Pull out extra fuel button and attempt to start again.

Check valve.

Disconnect supply hose from fuel pump.

- a. If steady flow is not present, replace fuel filter per paragraph 4-15.
- b. If engine still will not start, refer to General Support.

Air supply.

Check air cleaner.

- a. Check rain hood for blockage and/or damage to the system.
- b. If no other reason for blockage is apparent, service air filter (paragraph 3-15.2).

3. ENGINE SPEED IS UNSTEADY (HUNTING).

Engine problem

Notify General Support.

4. DENSE SMOKE FROM ENGINE EXHAUST AFTER START.

Oil level.

Shut down engine and check oil level (paragraph 3-4). Correct as necessary.

Air supply.

See 2 above.

TABLE 3-1. OPERATOR/CREW TROUBLESHOOTING PROCEDURES (CONTINUED).

MALFUNCTION/SYMPTOM	PROBABLE CAUSE	TEST OR INSPECTION/CORRECTIVE ACTION
---------------------	----------------	--------------------------------------

COMPRESSOR

5. COMPRESSOR OIL SIGHT GLASS SHOWS BUBBLES

Air trapped in oil pump

Vent pump and line (paragraph 3-14.1)

Oil pressure regulator.

Clean and adjust oil pressure regulator (paragraph 3-14.1).

6. OIL FOAM IN COMPRESSOR CRANKCASE.

Refer to Unit Maintenance.

7. COMPRESSOR WORKS IRREGULARLY.

V-Belt slipping

Replace or adjust as indicated (paragraph 3-14.2)

8. OIL RESIDUE IN DELIVERED AIR.

Purification filter cartridge.

Replace filter cartridge (paragraph 3-16.2).

9 COMPRESSOR DOES NOT ATTAIN FINAL PRESSURE

Condensate drain valves

Valves or fittings leaking Tighten.

Final stage safety relief valve opening too soon.

Replace safety relief valve.

Piston rings worn.

Refer to Unit Maintenance.

Excessive piston clearance

Refer to Unit Maintenance.

TABLE 3-1. OPERATOR/CREW TROUBLESHOOTING PROCEDURES (CONTINUED).

MALFUNCTION/SYMPTOM	PROBABLE CAUSE	TEST OR INSPECTION/CORRECTIVE ACTION
---------------------	----------------	--------------------------------------

10 COMPRESSOR OUTPUT VOLUME LOW.

Intake air cleaner filter clogged.

Replace air cleaner filter element (paragraph 3-14.3).

Safety relief valves not seating.

Replace safety relief valve.

First stage valve not closing properly.

Check and clean. Replace if defective. Refer to Unit Maintenance.

11 OUTLET FLOW RESTRICTED.

Clogged final separator.

Remove filter. Replace filter element (paragraph 3-16.3)

Pressure maintaining valve (PMV) set too high.

Check valve for correct opening pressure. Adjust as necessary (paragraph 3-16.1).

12 PRESSURE MAINTAINING VALVE OPERATES AT WRONG PRESSURE

Incorrect setting

Reset (paragraph 3-16.1).

Dirt on valve seat.

Clean and reseal

Damaged valve seat.

Replace valve seat.

13 SAFETY RELIEF VALVES BETWEEN STAGES RELEASING.

Intermediate pressure too high.

Check inlet and discharge valves of higher stage. Clean or replace.

Valves not closing properly.

Replace safety relief valves (see Chapter 6).

TABLE 3-1. OPERATOR/CREW TROUBLESHOOTING PROCEDURES (CONTINUED).

MALFUNCTION/SYMPTOM	PROBABLE CAUSE	TEST OR INSPECTION/CORRECTIVE ACTION
---------------------	----------------	--------------------------------------

14 EXCESSIVE OIL CONSUMPTION.

Check all cylinders

Replace rings and pistons as required (see Chapter 6).

15 INCORRECT OIL PRESSURE.

Air trapped in oil pump.

Vent oil pump and line (paragraph 3-14.1).

Incorrect regulator setting.

Reset (paragraph 3-14.1).

Foreign material in regulator.

Remove regulator. Clean and reset (paragraph 3-14.1).

16. INCORRECT INTERSTAGE PRESSURE.

Inlet or discharge valves in preceding stage malfunctioning.

Repair or replace valves Refer to Unit Maintenance.

Safety relief valves leaking.

Replace safety valves.

Piston in final stage binding in bushing.

Check floating piston (see Chapter 6).

Section IV. OPERATOR MAINTENANCE PROCEDURES

Paragraph		Page
3-14	Reciprocating Compressor	3-14
3-15	Diesel Engine	3-21
3-16	Purification System	3-27
3-17	Instruments	3-28
3-18	Tubing and Fittings	3-30
3-19	Replace Fill Hose Assembly	3-31

3-14. RECIPROCATING COMPRESSOR

A. INTRODUCTION. This section covers maintenance procedures at the operator level for the compressor module.

B. COMPRESSOR DATA.

The reciprocating compressor block used with the model CAPITANO-PD is designated by the manufacturer as KC-FH US GOV'T. Table 3-2 lists important features of the Reciprocating Compressor. Figure 3-7 illustrates the general arrangement of the Reciprocating Compressor components.

Table 3-2. Reciprocating Compressor

Item	Data
Block designation	KC-FH US GOV'T
No. of stages	3
No. of cylinders	3
Cylinder bore, first stage	2.76 in (70 mm)
Cylinder bore, second stage	1.42 in (36 mm)
Cylinder bore, third stage	0.58 in (14 mm)
Piston stroke	1.57 in (40 mm)
Direction of rotation, facing flywheel	CCW
Oil capacity	1.5 quarts (1.42 l)
Pressure range per stage:	
First stage	50-65 psi (3.45-4.48 bar)
Second stage	450-610 psi (31-42.1 bar)
Third stage	5000 psi max. (345 bar) *
Safety relief valve settings (non adjustable):	
First stage	115 psi (8 bar)
Second stage	725 psi (50 bar)
Third stage	According to operating pressure **
Pressure maintaining valve setting	2000 psi.

* Factory set at 3200 psi for model CAPITANO-PD.

** 3450 psi for model CAPITANO-PD.

- 1. Intercooler, 2nd stage.
- 2. Inter-filter, 2nd stage
- 3. Oil pressure regulator.
- 4. Cylinder, 3rd stage.
- 5. Oil filler cap/dipstick.
- 6. Safety relief valve, 2nd stage.
- 7. Air intake filter.
- 8. Cylinder, 1st stage.
- 9. Safety relief valve, 1st stage.
- 10. Cylinder, 2nd stage
- 11. Intercooler, 1st stage.
- 12. Oil drain plug.
- 13. Manual condensate drain valve.
- 14. Filter Mount

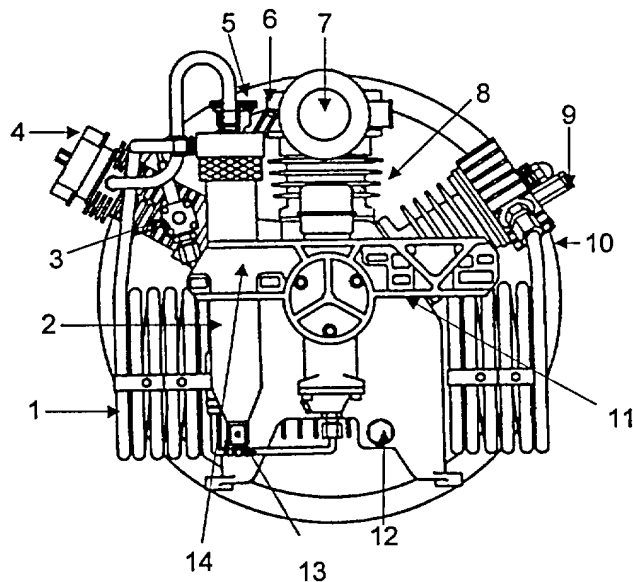

Figure 3-7. Reciprocating Compressor Components

Table 3-3 Compressor Repair Data

Stage	Item	Max.		min	
		in	mm	in	mm
First	Discharge valve spring length.	0.945	24	0.827	21
	Discharge valve stroke	0.049	1.25	0.039	1
	Valve seat bore diameter	0.049	1.25		
Second	Discharge valve spring length	0.945	24	0.827	21
	Discharge valve stroke	0.041	1.05	0.031	0.8
	Discharge valve seat bore	0.315	8		
	Inlet valve spring length	0.413	10.5	0.354	9
	Inlet valve stroke	0.049	1.25	0.039	1
Third	Inlet valve seat bore	0.492	12.5		
	Discharge valve seat bore.	0.157	4		
	Inlet valve stroke.	0.047	1.2	0.031	0.8
	Discharge valve stroke	0.047	1.2	0.035	0.9

3-14.1. COMPRESSOR LUBRICATION SYSTEM.

This task covers: A. Inspect B. Service C. Adjust

Tools:

Tool kit, General Mechanic's Set

Materials/Parts:

Oil
 Brush NSN 8020-00-224-8021
 Cloth, Lint-Free NSN 7920-00-044-9281

Equipment Conditions:

Compressor Unit Shut Down
 Purge All Air Pressure

A. Inspect.

1. Checking the Compressor Oil Level.

NOTE

Check oil level every day prior to putting compressor into operation.

WARNING

ENSURE THE UNIT IS SHUT DOWN AND THAT THE SYSTEM PRESSURE HAS BEEN BLED TO ZERO.

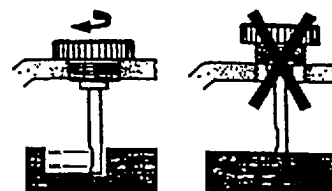

FIGURE 3-8. COMPRESSOR OIL LEVEL

- a. Unscrew and pull oil dipstick out (located at the top of the block).
- b. Wipe off dipstick with lint-free cloth; screw the dip stick all the way in, then remove again and examine (see figure 3-8).
- c. Oil level should rest between the indentation marks on the dipstick.
- d. If oil is required, add oil as necessary to fill compressor to level of full mark. Do not over fill.

B. Service.

1. Changing the Compressor Lube Oil.

CAUTION

The Federal Water Pollution Control Act prohibits the discharge of oil or oily waste into or upon the navigable waters of the United States or the waters of the contiguous zone, if the discharge causes a film or discoloration of the surface of the water or causes a sludge or emulsion beneath the surface of the water. Ensure a container of sufficient size is used when draining the oil.

- a. Run the compressor unit until it is warm. Turn off the compressor.

b. Vent any residual pressure from the system by opening and then closing the manual drain valves on separators and purge valve of the purification system

1. Open the filler cap slowly, allowing any residual pressure to vent from the crankcase.
2. Remove the cap/dipstick from the oil filler neck.
3. Place a suitable oil drain pan beneath the drain plug at the back of the unit.
4. Remove the oil drain plug from the compressor, (figure 3-9, item 3).
5. Allow the warm oil to totally drain.
6. Reinstall the oil drain plug.
7. Remove the oil drain pan. Dispose of the used oil in accordance with current instructions for waste oil disposal.

CAUTION

To avoid damage to the compressor, do not mix type or viscosity grades of oil. Do not over-fill.

c. To fill with oil, pour 1.5 quarts of oil slowly into the oil filler neck. Wait five (5) minutes after filling, check oil level (A above), if necessary add oil, reinstall the filler cap, then start the compressor unit.

d. Check the operation of the oil pump. It is working properly if no bubbles are visible in the oil pressure regulating valve sight glass. (See figure 3-10, item 3).

e. Vent the pump if bubbles are visible, (2 below).

2. Venting the Oil Pump.

a. Shut down the compressor and vent the crankcase.

b. Slowly loosen the tube nut (Figure 3-9, Item 2).

c. Turn the compressor by hand until bubble-free oil emerges from the fitting.

d. Tighten the tube nut.

C. Adjust.

1. Adjusting the Oil Pressure Regulating Valve.

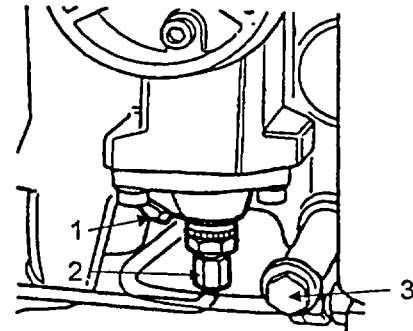

FIGURE 3-9. COMPRESSOR OIL PUMP AND DRAIN PLUG

NOTE

The compressor must be in operation. The oil pressure regulator is mounted on the third stage cylinder and adjusted to 850 psi (60 bar) (Normal operating range is 800 psi to 900 psi). The oil pressure is set at the factory and usually does not require adjustment.

- a. Remove cap nut (Figure 3-10, Item 1) to expose setscrew (2).
- b. Remove tube plug (4).
- c. Connect a calibrated oil pressure gauge to the oil pressure regulator test connector (4) to read oil pressure (the connector is 6mm L tube).
- d. Start compressor.
- e. Using a screwdriver, turn setscrew (2) in oil pressure regulator (5) to adjust oil pressure. Turn the setscrew clockwise to increase pressure; counterclockwise to reduce pressure.

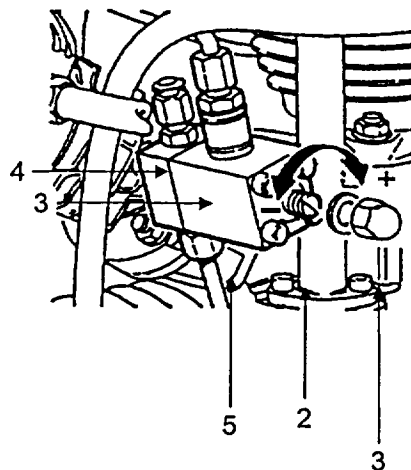

FIGURE 3-10. OIL PRESSURE REGULATOR

- f. Oil pressure should be 850 psi +/- 50 psi.
- g. If bubbles are observed in the regulator sight glass (3) on the oil pressure regulator (5), it is necessary to vent the pump; refer to paragraph 3-5.4 and 2. above.

3-14.2. COMPRESSOR DRIVE V-BELT

This task covers: A. Inspect B. Adjust C. Replace

Tools:

Tool kit, General Mechanic's Set

Materials/Parts:

V-Belt (PIN BET-0021)

Equipment Conditions:

Compressor Unit Shut Down
 Purge All Air Pressure
 V-Belt Guard Removed

A Inspect.

1 Inspecting the Drive System.

- a. Check tension of V-belt when joining the engine drive unit to the compressor unit.
- b. Press down on the belt midway between sheaves. Deflection should be 1/2 inch.

c. V-belt should be free of cracks, frayed edges, breaks in covering and/or broken cords. Sheave grooves should be free of excessive wear, corrosion and rough spots. The belt should fit in the groove without bottoming.

B. Adjust.

1. Adjusting the Belt Tension.

- a. Loosen the engine mounting bolts and slide the engine as necessary to obtain proper tension.

C. Replace.

1. Replacing the V-Belt.

a. Remove the engine unit V-belt guard (paragraph 2-7) Loosen the four bolts which hold the engine mounting bracket to the compressor frame and slide the engine toward the compressor. Remove old V-belt and replace it with a new V-belt size AP-78.

b. Run the compressor for a few minutes to seat the belt. Stop and restart the compressor while observing the belt There should be a slight bow on the bottom or slack side of the belt. If there is no bow, the belt is too tight. If the belt slips or squeals, it is too loose. In either case, readjust tension.

c. Replace engine unit V-belt guard after belt adjustments are complete.

3-14.3. COMPRESSOR INTAKE AIR CLEANER FILTER.

This task covers: A Inspect B. Service

Tools:

Tool kit, General Mechanic's Set

Materials/Parts:

- Brush NSN 8020-00-224-8021
- Lint-free cloth NSN 7920-00-044-9281
- Detergent, non-ionic NSN 7930-00-282-9699
- Filter element (PIN N00070)
- O-Ring (PIN 013757)
- O-Ring (P/N N04451)
- Grease, Halo Carbon NSN 9150-00-754-2760

Equipment Conditions:

- Secure equipment
- Purge air pressure

A dry micronic filter is used to filter the intake air (Figure 3-11).

A. Inspect.

1. Checking the Air Intake Hose.

- a. Check hose for damage.
- b. Inspect air intake prefilter, ensure it is free from obstruction.

B. Service.

1. Cleaning the Intake Filter.

- a. Remove cover (1) and filter element (2) (Figure 3-11, Item 2). Note position of element in housing.
- b. Clean the filter element with a brush or by blowing through it with low pressure compressed air, from inside out
- c. Clean inside of filter housing with a damp cloth and non-ionic detergent.

2. Reinstalling/Replacing the Filter Element.

a. Turn the element 90° on reinstallation and mark the end of the filter element in reference to the inlet opening of housing. Replace a dirty element once it has been turned three times.

b. Replace O-rings (3 & 4), if damaged. Lubricate O-rings with halo carbon grease when installing.

c. When reinstalling/replacing the element (2), ensure spring (5) on top cover (1) is placed properly.

3. Removing/Replacing the Intake Air Filter.

a. Loosen the clamp securing the air cleaner to the valve head.

b. Remove the air cleaner, replace if necessary.

c. Lubricate the O-ring on the valve head and reinstall the air cleaner.

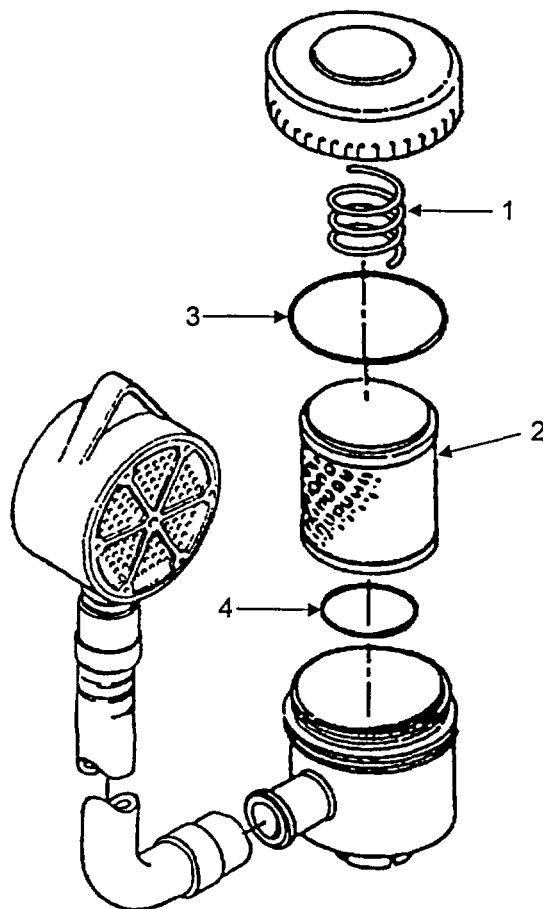

FIGURE 3-11. COMPRESSOR INTAKE AIR CLEANER FILTER

3-14.4 INTERMEDIATE FILTER.

This task covers: A. Service

Tools:

Tool kit, General Mechanic's Set

Materials/Parts:

- Lint-free Cloth NSN 7920-00-044-9281
- Grease, Halo Carbon NSN9150-00-754-2760
- Detergent, Non-ionic NSN7930-00-282-9699
- O-ring (P/N N03556)

Equipment Conditions:

- Engine Shut Down and Cool.
- System Purged of Pressure

A. Service.

1. Removing the Sintered Filter. Refer to figure 3-12.

a. Disconnect the inlet and outlet tubes from the filter head using an open end wrench.

b. Unscrew threaded collar (1). Remove filter head (2) and sintered filter assembly (3). Remove the center screw (4) to remove the filter element (5). Inspect O-ring (6) for damage. Replace if necessary.

2. Cleaning the Sintered Filter (5).

a. Clean the element using hot soapy water. Blow dry with compressed air.

3. Reassembling the Intermediate Filter.

a. Coat the threads and O-ring and the threads of the filter element with a thin coat of halo carbon grease.

b. Dry the inside of the filter housing with a clean cloth and check for corrosion before reinstalling the filter element. If excessive corrosion is found, refer to Unit Maintenance.

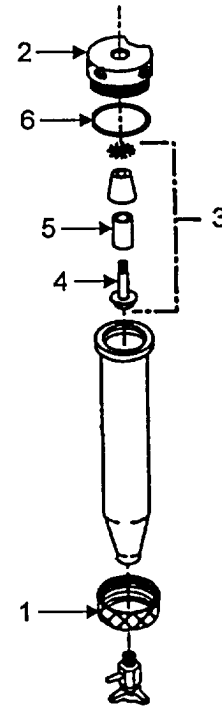

FIGURE 3-12. INTERMEDIATE FILTER

3-15. DIESEL ENGINE.

This task covers' A Inspect B. Service

Tools:

Tool kit, General Mechanic's Set

Materials/Parts

Oil
 Cloth, Lint-free NSN 7920-00-044-9281
 Copper Gasket PIN 50001500
 Equipment Conditions:
 Engine Shut Down After Running

A. INTRODUCTION. This paragraph covers maintenance procedures at the operator level for the diesel engine.

3-15.1. ENGINE OIL LEVEL.

A. Inspect.

1. Checking the Oil Level in Engine Crankcase.

- a. Remove dipstick (Figure 3-13, Item 1) and wipe with lint-free cloth.
- b. Insert dipstick all the way into the engine, then withdraw.
- c. Oil should coat the dipstick up to the top mark (2) (max.).
- d. If oil is below the top mark, remove cap (3) and add oil to bring oil level to top mark. Again check oil level to be sure oil coats dipstick to top (max.) mark.
- e. Check that oil cap (3) is tightly closed.

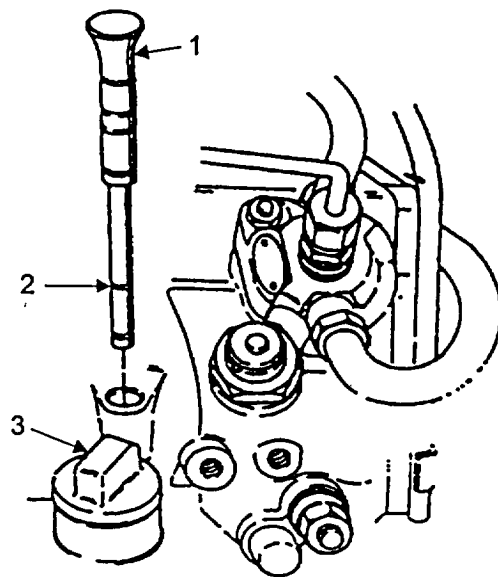

FIGURE 3-13. ENGINE OIL FILL

B. Service.

1. Changing the Oil.

- a. Change oil after first 20 hours of operation of new engine and then every 120 operating hours.

CAUTION

The Federal Water Pollution Control Act prohibits the discharge of oil or oily waste into or upon the navigable waters of the United States or the waters of the contiguous zone, if the discharge causes a film or discoloration of the surface of the water or causes a sludge or emulsion beneath the surface of the water. Ensure a container of sufficient size is used when draining the oil.

- b. With engine warm, place a suitable container under oil drain plug. Remove plug (figure 1-2) and drain oil. Inspect copper gasket, replace with new one if damaged. Reinstall plug.
- c. Remove oil cap (3) and fill engine crankcase to top mark on dipstick with oil. Crankcase capacity is 1.1 qt (1.0 l). Reinstall dipstick and cap.
- d. Remove the oil drain pan. Dispose of the used oil in accordance with current instructions for oil waste disposal.

3-15.2. ENGINE OIL BATH AIR CLEANER FILTER.

This task covers: A Service B. Replace.

Tools

Tool kit, General Mechanic's Set

Materials/Parts:

Engine Lubricating Oil
 Lint-free Cloth NSN 7920-00-044-9281
 Air Cleaner (P/N 4009400)
 Shim Set (P/N 01'-*4600)
 Equipment Conditions,
 Engine secured.

A. Service.

1. Servicing the Oil Bath Air Cleaner.

a Pull rain hood (4) off and check for dirt, debris and blockage. Replace rain hood if damaged.

b Unlatch two spring clips (Figure 3-14, Item 7).

c Remove bottom cup and gasket assembly (3) carefully so as not to spill oil.

d Empty oil from cup into a suitable container for disposal. Rinse cup with clean engine oil and wipe clean and dry with a lint free cloth

e Fill cup with clean engine lubricating oil to the three indicator holes in the side of inner cup in the bottom of the air cleaner.

f Replace cup and secure spring clips (7).

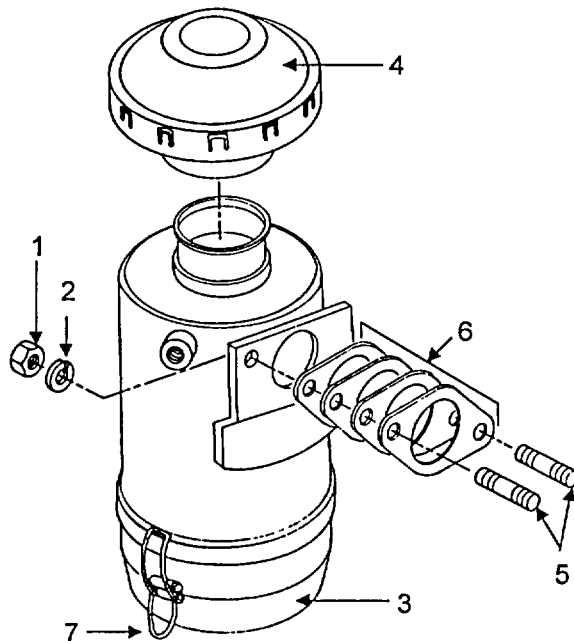

FIGURE 3-14. ENGINE OIL BATH AIR CLEANER FILTER

g. Wipe housing and rain cover clean with lint free cloth.

B. Replace.

1. Removing the Oil Bath Cleaner.

a Remove two 8 mm hex nuts (Figure 3-14, Item 1) and washers (2) from studs (5).

b Hold air cleaner in a vertical position and remove it from the crankcase.

c. Remove and discard the defective parts.

2. Installing the Oil Bath Cleaner.

a. Install the oil bath air cleaner and shims (6) with new parts in reverse order of removal.

3-15.3. ENGINE EXHAUST MUFFLER AND SPARK ARRESTER.

This task covers: A. Inspect B. Replace.

Tools:

Tool kit, General Mechanic's Set Scratch
Wire Brush NSN 7920-00-044-4857

Materials/Parts:

Shim Set (P/N 01284600)
Muffler (P/N MUF-0018)
Spark Arrester (P/N 18782-AP)

Equipment Conditions:

Engine secured, Muffler Cold

A. Inspect.

1. Cleaning the Muffler for Inspection.

a. Remove two hex nuts (Figure 3-15, Item 6), and washer (9) and remove the long bolt (2). Remove the bottom cup (10).

b. Remove u-bolt (7) and spark arrester (8).

c. Remove hex nut (11) and disassemble spark arrester.

d. Using a stiff brush, clean soot, carbon, and dirt from the cup, each spark arrester plate, and from the inside of muffler (1) and bottom cup (10).

NOTE

For best results, clean all parts dry, without solvents.

e. examine the cleaned parts for corrosion or burn-through

f. If parts are satisfactory, reassemble in reverse order. If unserviceable, replace the muffler.

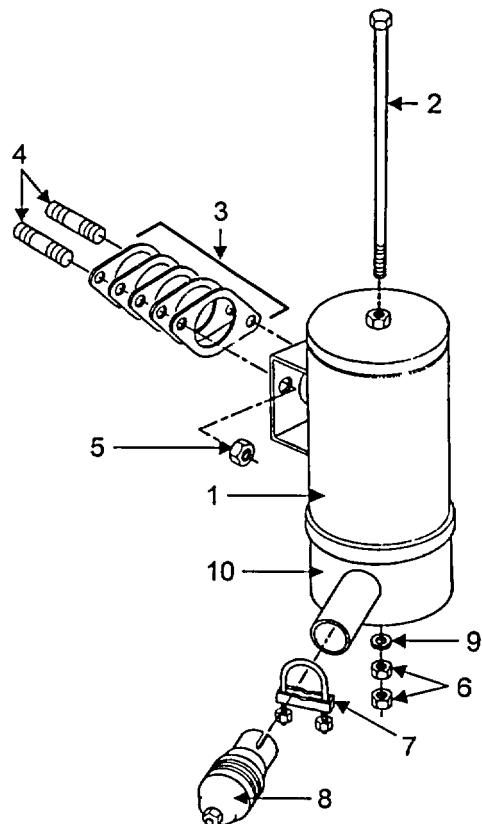

FIGURE 3-15. ENGINE EXHAUST MUFFLER AND SPARK ARRESTER

B. Replace

1. Replacing the Muffler.

a. Remove hex nuts (5) from studs (4) which secure the muffler to the crankcase. Remove and discard the shim set (3).

b. Replace the shim set, complete muffler and spark arrester with new parts as necessary, in reverse order of removal.

3-15.4. THROTTLE CONTROL HAND LEVER.

This task covers' A. Inspect

Tools:

Materials/Parts:
Equipment Conditions:
Engine Running

A. Inspect

1. Check the throttle control lever for movement and results. Operate the throttle control lever and observe the reaction of the engine. Movement should be snug but without binding throughout the full range of travel. With the engine running, ensure the throttle level produces the desired control. If deficiencies are observed, refer to Direct Support Maintenance (paragraph 5-6.9).

3-15.5. ENGINE FUEL LINES, HOSES, AND FITTINGS.

This task covers: A. Inspect B. Replace.

Tools:

Tool kit, General Mechanic's Set

Materials/Parts: Bulk Fuel Lines.
(PIN 03493600)
(P/N HOS-R-0031)
(P/N 03493300)
(PIN HOS-R-0029)
Equipment Conditions:
Unit Must Be Cool, Fuel Tank Empty
Well Ventilated Area

A Inspect.

1. Inspecting Fuel Lines and Fittings

a. Inspect all fuel lines for leaks, chaffing, loose fittings, or signs of deterioration. Pay particular attention to ends of hoses and fittings. Nylon ties should hold fuel lines firmly in place without vibration. Loose fittings may be tightened. Any hose that shows sign of swelling or leaking must be replaced.

2. Removing/Replacing the Defective Fuel Lines.

a. The following instructions cover all fuel lines. Only those found to be defective need to be removed and replaced Refer to Figure 3-16.

B. Replace.

WARNING

DEATH OR SERIOUS INJURY COULD OCCUR IF FUEL IS NOT HANDLED CAREFULLY. USE IN A WELL VENTILATED AREA AWAY FROM OPEN FLAME, ARCING EQUIPMENT, IGNITION SOURCES, HEATERS OR EXCESSIVE HEAT ENGINE MUST BE SHUT DOWN AND COOL BEFORE REFUELING. ALWAYS STORE FUEL IN PROPER, MARKED CONTAINERS. DO NOT SMOKE.

CAUTION

As each fuel hose, connection, or connection port is removed be sure to tape over or plug each open connection in order to prevent contaminants from entering the fuel system.

1 Non-pressure Lines.

a. The fuel lines and their type and service are shown in Figure 3-16. All non-pressure lines are made of rubber hose suitable for use with diesel fuel oil. Connections to the tank are made by banjo elbows. The ring pieces serve as hose barbs. All hose end connections are made fast with hose clamps. Replacement hoses may be cut to proper length from bulk material of like kind (reference Appendix F).

1. Fuel Filler Cap
2. Fuel Filter
3. Banjo Elbow
4. Gravity Feed Fuel Line (Hose)
5. Diesel Engine
6. Fuel Injector
7. Fuel Pump w/Automatic Venting Device
8. Return Fuel Line (Hose)
9. Fuel Pressure Line (Steel)
10. Vent Line (Hose)
11. Hose Barb Tee
12. Return Fuel/Vent Line (Hose)
13. Banjo Elbow
14. Fuel Tank

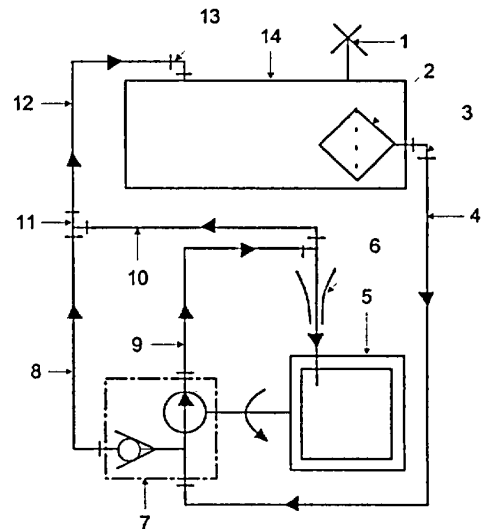

Figure 3-16. Diagram of Fuel Lines

2 Pressure Lines

a. The line from the fuel pump to the Injector is subject to high pressure. This is a numbered replacement part, refer to RPSTL TM 5-4310-393-24P. To replace, loosen the tube fitting nut at each end. Remove the tube and replace with a new part in reverse order.

NOTE

After replacement of any fuel line(s), start the engine and check for leaks. Tighten hose clamp or other fittings as appropriate.

3-16 PURIFICATION SYSTEM

This task covers: A. Inspect B. Service

Tools:

Materials/Parts:

Equipment Conditions:

A. INTRODUCTION.

The purification system of the model CAPITANO-PD consists of three parts, the Pressure Maintaining Valve, The Purification Cylinder, and the Oil/water Separators.

3-16.1. PRESSURE MAINTAINING VALVE

This task covers: A. Inspect

Tools:

Materials/Parts:

Equipment Conditions:

A. Inspect.

1. Depressurizing the System.

- a. Depressurize the final separator and purification chamber by slowly opening the manual drain valve (Figure 1-1, item 12).

2. Checking the PMV for Proper Operation.

- a. Close manual drain valve and start compressor. Observe the final pressure gauge and note the pressure at which the PMV opens Pressure should read 2000 PSI (138 BAR) If opening pressure is incorrect, refer to Direct Support Maintenance.

3-16.2. PURIFICATION CYLINDER.

This task covers: A Inspect B. Service

Tools:

Tool Kit, General Mechanic's Set

Purifier Wrench (P/N WRH-0002)

Materials/Parts:

Grease, Halo Carbon 9150-00-754-2760

O-ring (PIN N04736, N04735)

Equipment Conditions:

Compressor Shut Down

All Air Pressure Purged

A. Inspect.

1. Inspecting the Runtime Log.

- a. The only required operator service to the purification cylinder is reviewing the runtime logs to monitor life of the purification cartridge.

2. Checking the Run-Time Log.

- a. Replace the cartridge at interval specified in Table 2-2. If cartridge life has expired, replace per step B.

B. Service.

1. Replacing the Purification Cartridge.

- a. Replace the purification cartridge at interval specified in Table 2-2.
- b. Open condensate drain valves and purge valve to remove all pressure from the system.
- c. Unscrew the top cover plate with the special purifier wrench and lift cartridge out by the clip at the top of the cartridge.

CAUTION

To avoid reducing the effectiveness of the cartridge, do not remove replacement cartridge from its protective cover until ready to place it in the purification cylinder.

- d. Remove the plastic plug and apply a light coat of halo carbon grease to the O-rings supplied for the bottom of the cartridge.
- e. Carefully insert the cartridge into the cylinder. Gently press the cartridge to properly seat it.
- f. Inspect and replace any damaged O-rings, tightly coat all O-rings with halo carbon grease when installing.
- g. Reinstall cylinder cap.
- h. Start the compressor, close the drain and purge valves and observe pressure build-up. Pressure will not build in the system unless the purification cartridge is properly seated in the cylinder and drain and purge valves are closed.

3.16.3. OIL/WATER SEPARATOR.

This task covers A Service

Tools:

Tool Kit, General Mechanic's Set
Wrench, Strap (NSN 5120-01-192-9406)

Materials/Parts:

Lint-free Cloth NSN 7920-00-9281
Grease, Halo Carbon NSN9150-00-754-2760
Detergent, Non-ionic NSN7930-00-282-9699

Equipment Conditions'

Equipment secured
System Purged of Pressure
Intake Filter Removed

A. Service.

1. Removing the Sintered Filter.

a. Disconnect the inlet and outlet tubes from the separator head.

b. Unscrew and remove separator head (1) using the strap wrench

c. Unscrew the sintered filter element (2) from the separator head. Remove the center screw to remove the filter element

2. Cleaning the Sintered Filter.

a. Clean the element using hot soapy water. Blow dry with compressed air.

3. Reassembling the Oil/water Separator.

a. Coat the threads and O-rings and the threads of the filter element with a thin coat of halo carbon grease.

b. Dry the inside of the filter housing with a clean cloth and check for corrosion before reinstalling the filter element. If excessive corrosion is found, refer to Unit Maintenance.

c. Reinstall in reverse sequence of disassembly.

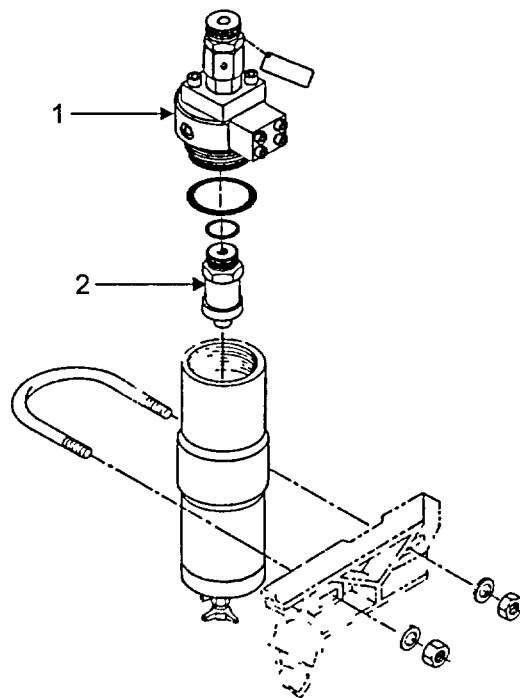

FIGURE 3-17. OIL/WATER SEPARATOR

3-17. INSTRUMENTS.

This task covers: A. Inspect B. Replace

Tools:

Tool Kit, General Mechanic's Set

Materials/Parts:

Tape, Teflon NSN 8030-00-889-3534

Detergent, Non-ionic NSN 7930-00-282-9699

Distilled Water NSN 6810-00-297-9540

Equipment Conditions:

Equipment secured

System Purged of Pressure

A. Inspect.

1. Inspecting the Instruments for Damage.

a. Inspect all system pressure gauges and hourmeters for physical damage such as broken or cracked lenses, leaking fittings and so forth. If gauges are suspected to be inaccurate, they should be calibrated. Refer to General Support Maintenance.

B. Replace.

1. Replacing the Gauges.

a. Replace gauges by unscrewing the pressure line fitting on the back of the gauge, then unscrewing the bezel nuts on the back of the gauge, which hold it in its mounting hole. Replace in reverse order of removal. Soap test pressure connections using non-ionic detergent solution. Make sure to keep any foreign matter from entering the pressure tubing.

2. Replacing the Hourmeters.

a. Hourmeters are provided to record hours of operation for the compressor section and the engine section. Each hourmeter is mounted in a bracket having two mounting positions. By design the hourmeters will not record when placed in with the face out of a horizontal position by more than 45°. For operation use the HOURMETER ON mounting hole in the bracket. For transportation of the unit, mount the hourmeter in the HOURMETER OFF position. To relocate the hourmeter from one position to the other:

1. Unscrew the large plastic mounting nut at the back of the bracket and remove the hourmeter.
2. Place the hourmeter in the appropriate mounting hole and re-secure the nut to hold the hourmeter in place.

3-18. TUBING AND FITTINGS.

This task covers. A. Inspect

Tools:

Tool Kit, General Mechanic's Set

Materials/Parts:

Tape, Teflon NSN 8030-00-889-3534

Detergent, Non-ionic NSN 7930-00-282-9699

Distilled Water NSN 6810-00-297-9540

Equipment Conditions:

Equipment Operating

A. Inspect

1. Checking the Tubing for Crimps, Bends, or Pit Holes.

a. If any damage is apparent, refer to step 2a.

2. Checking for leaks.

a. Check for leaks using a non-ionic detergent while unit is at full pressure. Replace hoses if cracking or deterioration is found. Replace tubing and fittings if excessive pitting, bending or crimping, or deformation is found. Always perform a leak test after replacing tubes, hoses, or fittings

3. Securing the unit and purging air (paragraph 2-3).

4. Tightening of the fittings as necessary.

a. Do not over tighten.

b. Do not tighten fitting with pressure in line.

3-19. REPLACE FILL HOSE ASSEMBLY.

This task covers' A Inspect B. Replace

Tools:

Tool Kit, General Mechanic's Set)

Materials/Parts,

Tape, Teflon NSN 8030-00-889-3534

Detergent, Non-ionic NSN 7930-00-282-9699

Distilled Water NSN 6810-00-297-9540

Equipment Conditions:

Equipment secured

System Purged of Pressure

A. Inspect.

1. Checking for Leaks.

a. Check for leaks using a non-ionic detergent while hose is at full pressure.

B. Replace.

1. Replacing the Fill Hose.

a. Replace the fill hose if cracking or deterioration is noted. Always perform a leak test after replacing hoses or fittings

CHAPTER 4
UNIT MAINTENANCE INSTRUCTIONS

		Page
Section I	Direct Support Trouble Shooting Procedures	4-1
Section II	Service Upon Receipt	4-1
Section III	Unit Preventive Maintenance Checks and Services (PMCS)	4-2
Section IV	Unit Troubleshooting	4-5
Section V	Unit Maintenance Instructions	4-11
Section VI	Preparation for Storage or Shipment	4-33
Section VII	Cleaning Procedures	4-36

Section I. DIRECT SUPPORT TROUBLE SHOOTING PROCEDURES.

This chapter contains unit level preventive maintenance checks and services, troubleshooting, maintenance and instructions for placing the equipment into storage.

		Page
Paragraph		
4-1	Common Tools and Equipment	4-1
4-2	Special Tools TMDE, and Support Equipment.	4-1
4-3	Repair Parts	4-1

4-1. COMMON TOOLS AND EQUIPMENT.

For authorized common tools and equipment, refer to the Modified Table of Organization and Equipment (MTOE) applicable to your unit.

4-2. SPECIAL TOOLS, TMDE, AND SUPPORT EQUIPMENT.

Refer to Repair Parts and Special Tools List RPSTL TM 5-4310-393-24P and the Maintenance Allocation Chart pertaining to unit maintenance for the CAPITANO-PD Reciprocating Compressor Unit.

4-3. REPAIR PARTS.

Repair parts are listed and illustrated in the RPSTL TM 5-4310-393-24P.

Section II. SERVICE UPON RECEIPT

		Page
Paragraph		
4-4	Service Upon Receipt	4-1

4-4. SERVICE UPON RECEIPT.

The CAPITANO-PD Reciprocating Compressor Unit may arrive at your unit crated or unboxed on a common carrier. "Service Upon Receipt" instruction may be accomplished at the operator level. Refer to Chapter 3, Section II. for details

Section III. UNIT LEVEL PREVENTIVE MAINTENANCE CHECKS AND SERVICES

Paragraph		Page
4-5	General	4-2
4-6	Service Interval	4-2
4-7	Reporting Repairs	4-2
4-8	General PMCS Procedures	4-2
4-9	Specific PMCS Procedures	4-3

4-5. GENERAL.

To ensure that the CAPITANO-PD Reciprocating Compressor Unit is ready for operation at all times, It must be inspected on a regular basis so that defects may be found before they result in serious damage, equipment failure, or injury to personnel. This section contains systematic Instructions on inspections, adjustments, and corrections to be performed by unit maintenance.

4-6. SERVICE INTERVALS.

- a. perform PMCS, found in Table 4-1, at the following intervals:
 - (1) Perform Monthly (M) PMCS once every month.
 - (2) Perform Biannually (B) PMCS twice each year.
 - (3) Perform Annual (A) PMCS once each year.

4-7. REPORTING REPAIRS.

Report all defects and corrective actions on DA Form 2404. If a serious problem is found, report It to your supervisor immediately.

4-8. GENERAL PMCS PROCEDURES.

WARNING

DRY CLEANING SOLVENT P-D-680 IS TOXIC AND FLAMMABLE. ALWAYS WEAR PROTECTIVE GOGGLES AND GLOVES, AND USE ONLY IN A WELL-VENTILATED AREA. AVOID CONTACT WITH SKIN, EYES AND CLOTHES AND DO NOT BREATHE VAPORS. DO NOT USE NEAR OPEN FLAME OR EXCESSIVE HEAT. THE SOLVENT'S FLASH POINT IS 1 00°F-1 30°F (38°C-590C). IF YOU BECOME DIZZY WHILE USING CLEANING SOLVENT IMMEDIATELY GET FRESH AIR AND MEDICAL HELP. IF SOLVENT CONTACTS EYES, IMMEDIATELY WASH YOUR EYES AND GET MEDICAL AID.

DO NOT USE DRY CLEANING SOLVENT P-D-680 ON ANY DIVING LIFE SUPPORT AIR SYSTEM COMPONENTS. ONLY USE THE CLEANING AGENTS SPECIFIED IN CHAPTER 4, SECTION VII FOR CLEANING DIVING LIFE SUPPORT AIR SYSTEM COMPONENTS. USE OF UNAUTHORIZED CLEANING AGENTS COULD RESULT IN PERSONNEL INJURY OR DEATH.

- a. Keep equipment clean. Dirt, oil and debris may cover up a serious problem. Clean as you work and as needed. Use dry cleaning solvent (Item 22, Appendix E) on all metal surfaces. Use soap and water on rubber, plastic, and painted surfaces.

- b. While performing PMCS, inspect the following components:
 - (1) **Bolts, Nuts, and Screws.** Ensure that they are not loose, missing, bent, or broken. Tighten any that are

loose.

(2) **Welds.** Inspect for gaps where parts are welded together. Report bad welds to your supervisor.

(3) **Electric Wires or Connectors.** Inspect for cracked or broken insulation, bare wires, and loose or broken connectors. Make repairs or replace as required.

(4) **Hoses, Lines, and Fittings.** Inspect for wear, damage, and leaks. Ensure that clamps/fittings are tight. If a leak originates, from a loose fitting or connector, tighten it. If a component is broken or worn, correct problem if authorized by the Maintenance Allocation Chart (MAC (Appendix B)). If not authorized, report it to your supervisor.

c. Separation into portable sections

(1) Prepare for movement (paragraph 2-11 steps a through j)

(2) Using the draw latches, unlatch the model CAPITANO-PD into two separate units

(3) Forward the malfunctioning unit to the appropriate maintenance activity

4-9. SPECIFIC PMCS PROCEDURES.

a. Unit level PMCS are provided in Table 4-1. Always perform PMCS in the order listed. Once it becomes a habit, anything that is not right can be spotted in a minute. If anything wrong is discovered through PMCS, perform the appropriate troubleshooting task in Section IV of this chapter. If any component or system is not serviceable, or if given procedures do not correct problem, notify your supervisor.

b. Before performing preventive maintenance, read all the checks required for the applicable interval and prepare tools needed to make all checks. Have several clean rags (Item 23, Appendix E) handy. Perform all inspections at the applicable interval.

c. The columns in Table 4-1 are defined as follows:

(1) Item No. Provides a logical sequence for PMCS to be performed and is used as a source of item numbers for the "TM ITEM NO" column on DA Form 2404 in recording PMCS results.

(2) Interval. Specifies interval at which PMCS is to be performed.

(3) Item to be Inspected. Lists the system and common name of items that are to be inspected. Included in this column are specific servicing, inspection, replacement, or adjustment procedures to be followed.

(4) Procedures. Tells you how to do the required check or service.

Table 4-1. Unit Preventive Maintenance Check and Services (PMCS)

Item No.	Interval			M-Monthly	B-BIANNUALLY	A-Annually
	M	B	A	ITEM TO BE INSPECTED		PROCEDURES
1		•		Diesel Engine		Remove the diesel engine if It needs to be removed for repairs or if it is non-repairable (paragraph 4-13.1).
2	•			Engine Cylinder Head Valves		Check tappet clearance, check decompression mechanism paragraph 4-13.2).
3		•		Engine Fuel Injector		Remove, Test, Install (paragraph 4-13.3).
4		•		Compressor Cooling System		Inspect, Replace if damaged (paragraph 4-14.1).
5		•		Compressor Lubrication System		Inspect, Repair, Replace (paragraph 4-14.2).
6		•		Compressor Impeller/Groove Pulley		Inspect, Remove, Repair, Replace (paragraph 4-14.3).
7		•		Compressor Valve Head and Valves		Inspect, Replace (paragraph 4-14.4, 4-14.5, & 4-14.6).
8		•		Fuel Filter		Replace the fuel filter annually or after every 480 hours of operation which ever comes first (paragraph 4-15)
9		•		Purifier Cylinder		Inspect, Replace if corrosion is excessive or if otherwise defective (paragraph 4-16).
10		•		Oil/Water Separators		Inspect, Replace as necessary (paragraph 4-17).
11	•			Pressure Maintaining Valve		Adjust, Replace (paragraph 4-18).
12		•		Interstage Pressures		Check (paragraph 4-19).
13		•		Tubing and Fittings		Replace if damaged (paragraph 4-20)
14		•		Safety Relief Valves		Remove and bench test all safety valves every 6 months to ensure proper setting and function. Replace defective valves. Leak test after installation.
15		•		Reciprocating Compressor		Remove the compressor as required for repair or if It needs to be replaced (paragraph 4-14.7).
16		•		V-Belt		Remove belt guard and visually inspect the drive V-belt for wear, fraying, and peeling. Check belt tension. Replace V-belt if damaged or worn. (paragraph 3-14.2)

Section IV. UNIT TROUBLESHOOTING PROCEDURES

Paragraph		Page
4-10	General	4-5
4-11	Explanation of Columns	4-5
4-12	Troubleshooting Procedures.	4-5

4-10. GENERAL.

a. This section provides information for identifying and correcting malfunctions which may develop when operating or maintaining the Service Unit.

b. Before performing troubleshooting, read and follow all safety instructions found in the Warning Summary at the front of this manual.

c. This section cannot list all malfunctions that may occur, nor all probable causes and corrective actions. If a malfunction is not listed, or is not corrected by the listed corrective actions, notify your supervisor.

d. When troubleshooting a malfunction:

(1) Question the operator to obtain any information that might help determine the cause of the problem. Before continuing, ensure that all applicable operator/crew troubleshooting (Chapter 3, Section III) was performed.

(2) Identify the general area of the Servicing Unit where the problem has occurred for instance, if the cylinders are not filling correctly, go to the **COMPRESSED GAS SYSTEM** listing Then, review the malfunction/symptom description that describes your problem. Headings at the top of each page show how each troubleshooting procedure is organized: **MALFUNCTION/SYMP TOM, PROBABLE CAUSE, and TEST OR INSPECTION/CORRECTIVE ACTION.**

(3) Perform each step in the order listed until the malfunction is corrected. DO NOT perform any maintenance task unless the troubleshooting procedure tells you to do so.

4-11. EXPLANATION OF COLUMNS.

a. The columns in Table 4-2 are defined as follows-

- 1) MALFUNCTION/SYMP TOM A visual or operational indication that something is wrong with the Reciprocating Compressor Unit.
- (2) PROBABLE CAUSE A procedure that isolates the problem within a component or system.
- (3) TEST OR INSPECTION/ CORRECTIVE ACTION A procedure to correct the problem.

4-12. TROUBLESHOOTING PROCEDURES.

The Unit Maintenance troubleshooting procedures are found in Table 4-2.

Table 4-2. Direct Support Troubleshooting Procedures

MALFUNCTION/SYMPTOM	PROBABLE CAUSE	TEST OR INSPECTION/CORRECTIVE ACTION
----------------------------	-----------------------	---

RECIPROCATING COMPRESSOR**1. COMPRESSOR WILL NOT LOAD.**

Stage safety valve.

Replace defective safety valve.

Purifier cartridge not in place.

Check purifier cartridge.

2. COMPRESSOR OUTPUT LOW.

Compressor running too slow.

Check engine throttle setting.

Intermediate stage safety valve.

Perform intermediate pressure check.

Compressor valves or rings.

Check, repair/replace as necessary.

3. LOW COMPRESSOR OIL PRESSURE.

Oil pressure regulator setting.

Adjust, repair or replace as needed.

4. COMPRESSOR AIR HAS AN OILY TASTE.

Purifier cartridge.

Replace cartridge.

Oil pressure regulator pressure set too high.

Adjust pressure regulator.

Table 4-2. Direct Support Troubleshooting Procedures (Continued)

MALFUNCTION/SYMPTOM	PROBABLE CAUSE	TEST OR INSPECTION/CORRECTIVE ACTION
----------------------------	-----------------------	---

5. SIGHT GLASS SHOWS AIR BUBBLES.

Oil pressure regulator.

Clean and adjust regulator.

Oil pump final pressure.

Clean and adjust pump.

Third stage piston clearance.

Replace piston.

6. COMPRESSOR DOES NOT ATTAIN FINAL PRESSURE.

Final stage safety valve

Replace as necessary.

Drain valves open or leaking.

Check drain valves.

Intermediate stage pressures

Replace valves/rings as needed.

7. EXCESSIVE VIBRATION.

Fuel timing of engine.

Check, adjust as necessary.

Loose mounting bolts.

Check, adjust as necessary.

Cracked frame.

Weld as needed.

8. NO OIL PRESSURE.

Oil pump failure.

Test and service as required.

Oil pressure regulator.

Test and service as required.

Table 4-2. Direct Support Troubleshooting Procedures (Continued)

MALFUNCTION/SYMPTOM	PROBABLE CAUSE	TEST OR INSPECTION/CORRECTIVE ACTION
---------------------	----------------	--------------------------------------

9. SAFETY VALVES BETWEEN STAGES RELEASING PRESSURE.

Next stage inlet/discharge valves.

Repair/replace as needed.

Stage safety valve bad.

Replace safety valve.

10. ENGINE WILL NOT START.

No fuel.

Check fuel supply and fuel lines. Correct as required.

Injector.

Check, repair or replace as needed.

Inadequate cranking speed.

Too high a starting load.

Unload the compressor by opening drain/bleed valves.

Oil viscosity too high.

Change oil to suit.

11. ENGINE GIVES POOR PERFORMANCE.

Fuel system.

Clean fuel system.

Exhaust back pressure.

Clean/Replace muffler or spark arrester if required.

12. ENGINE BACKFIRES.

Fuel delivery.

Adjust timing as needed.

Table 4-2. Direct Support Troubleshooting Procedures (Continued)

MALFUNCTION/SYMPTOM	PROBABLE CAUSE	TEST OR INSPECTION/CORRECTIVE ACTION
---------------------	----------------	--------------------------------------

13. EXCESSIVE ENGINE OIL CONSUMPTION.

Tappet clearance.

Adjust as needed.

Valve guides.

Check/Replace defective guides.

Piston/cylinder.

Check/Replace defective components

14. ENGINE SMOKES WHITE.

Injector or injector sealing washer.

Clean or replace as necessary.

Fuel pump timing

Retime pump.

Injector pump pressure.

Repair/Replace as necessary.

Engine compression low.

Test for compression. Replace rings and piston if required

15. ENGINE SMOKES BLUE.

Valve guides.

Check valve guides. Replace defective components.

Poor compression.

Replace rings and piston if required. Test for compression.

16. ENGINE SMOKES BLACK.

Table 4-2. Direct Support Troubleshooting Procedures (Continued)

MALFUNCTION/SYMPTOM	PROBABLE CAUSE	TEST OR INSPECTION/CORRECTIVE ACTION
---------------------	----------------	--------------------------------------

Injector.

Clean or replace injector.

Fuel delivery (timing).

Adjust timing as needed.

Fuel quality.

Adjust as necessary.

Engine compression.

Run compression test Notify General Support.

17. EQUIPMENT DOES NOT RUN SMOOTHLY.

Broken or loose engine or compressor mounts.

Repair as needed

Section V. UNIT SUPPORT MAINTENANCE PROCEDURES

Paragraph		Page
4-13	Diesel Engine	4-11
4-14	Reciprocating Compressor	4-15
4-15	Fuel Filter	4-29
4-16	Purification Cylinder	4-29
4-17	Oil/Water Separators	4-30
4-18	Pressure Maintaining Valve	4-31
4-19	Interstage Pressures	4-32
4-20	Tubing and Fittings	4-33

4-13 DIESEL ENGINE

A. INTRODUCTION. This paragraph covers maintenance and repair activities for the diesel engine at the Unit Level.

4-13.1. REPLACE ENGINE

This task covers: A. Remove B. Install

Tools:

- Tool Kit, General Mechanic's Set
- Shop Equipment, Automotive Maintenance and Repair
- Suitable lifting device to handle 200 lb

Materials/Parts,

- Replacement Engine (P/N ENG-0040)
 - Equipment Conditions'
 - Engine Unit Shut Down
 - Fuel Tank Empty
 - Engine and Compressor Sections Separated (paragraph 4-8C)
-

A. Remove

1. Removing the Engine.

- a. Remove the fuel lines between the fuel tank and engine at the engine end. Cap the fuel lines and plug the engine connections
- b. Attach a suitable lifting device to the lifting eye on the engine The engine weighs approximately 106 lb (48 kg).
- c. Remove the hold-down bolts securing the engine to the slotted engine supports and lift the engine out of the engine frame.

B Install

1. Installing the Engine

- a. Attach the lifting device to the new engine lifting eye. Lift high enough to clear engine frame then lower engine into engine frame.
- b. Align engine mounts to slotted holes in the base and secure with the mounting bolts.
- c. Remove closure fittings as necessary and connect the fuel lines to the new engine.
- d. When the engine unit is reassembled with a compressor unit, it will be necessary to loosen the engine hold-down bolts and align the engine sheave with the compressor drive sheave. With the grooves of the two sheaves in line,

adjust tension on the V-belt (see paragraph 3-14.2). When engine and compressor are in proper alignment, and V-belt tension is correct, retighten the hold down bolts.

4-13.2. ENGINE CYLINDER HEAD AND VALVE ASSEMBLY.

This task covers: A. Inspect B. Adjust C. Check
D. Install

Tools:

Tool Kit, General Mechanic's Set
Torque Wrench

Materials/Parts:

Valve Cover Gasket (PIN 03208902

Equipment Conditions:

Engine Unit Shut Down and cold

A. Inspect.

1. Checking the Tappet Clearance.

a. Rotate decompression lever clockwise until audible click is heard.

b. Loosen the screw (1) securing the valve cover vent line clamp (3) with an open end wrench (see figure 4-1).

c. Remove valve cover retaining nuts (4), and washers (5) lift off valve cover (6) and gasket (7).

d. Using the hand crank, turn engine slowly in the direction of rotation until compression resistance is felt.

e. Using a 0.004 inch (0.10mm) feeler gauge, measure distance between rocker arm and valve stem

f. Tappet clearance is correct when this measurement is 0.004 inch (0.10mm) when engine is cold and there is a slight drag felt on the feeler gauge.

B. Adjust.

1. Adjusting the Tappet Clearance and Decompression Mechanism.

a. Put decompression lever (Figure 4-2, Item 1) in the RUN position. See figure 4-3.

b. Turn engine clockwise when facing throttle control lever until compression resistance can be felt.

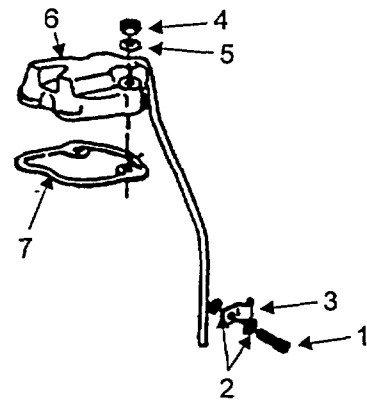

Figure 4-1. Removing Valve Cover

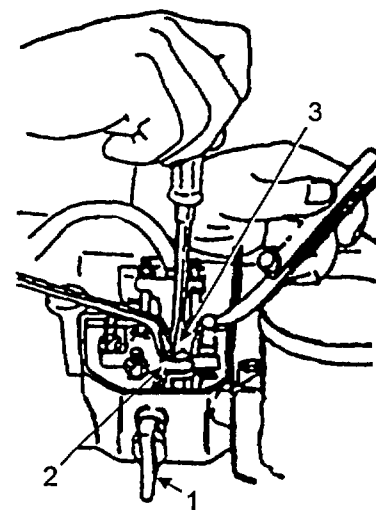

Figure 4-2. Tappet Adjustment

c. Check clearance between rocker and valve stem with a feeler gauge. Tappet clearance cold should be 0.004 inch (0.10mm). To correct clearance, loosen nut (Item 2, figure 4-2).

d. Adjust screw (Figure 4-2, Item 3) with a screwdriver until feeler gauge can be pulled between rocker and valve stem with very slight resistance after nut (2) has been tightened.

C. Check

1. Checking the Decompression Mechanism Setting

- a. Rotate the decompression lever (Figure 4-2, Item 1) clockwise to START position (see Figure 4-3).
- b. Verify that the engine is decompressed by turning engine clockwise with the crank handle.
- c. If adjustment of decompression mechanism is indicated, refer to Direct Support Maintenance.

D. Install.

1. Reinstalling the Valve Cover.

- a. Position a new gasket (Item 7, figure 4-1) on the mating surface of the cylinder head.
- b. Position the valve cover (6) on the cylinder head and secure with washers (5) hex nuts (4) Torque to 35 Nm (25 lb.-ft) then additional 1/8 turn with T-handle & socket.
- c. With screw (1) and washers (2) reinstall the vent line clamp (3) and tighten with an open-end wrench

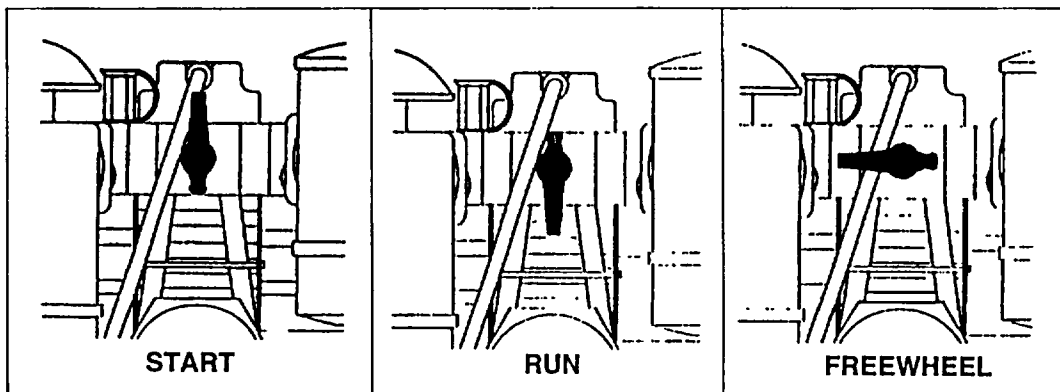

Figure 4-3. Decompression Lever Positions

4-13.3. FUEL INJECTOR.

This task covers: A. Remove B. Test C. Install

Tools:

- Tool Kit, General Mechanic's Set
- Torque Wrench
- Shop Equipment, Automotive
- Maintenance and Repair
- Testing Device 60462800
- Torque Wrench

Materials/Parts:

- Diesel Fuel (NSN 9140-00-286-5294)
- Grease (NSN 9150-00-754-2760)
- Joint Washers (P/N 40003100)

Equipment Conditions:

- Fuel Pressure Line Removed

A. Remove.

1. Removing the Injector.

CAUTION

The fuel injection system is extremely intricate and complex. All possible care should be taken in the removal, inspection, testing, and reassembly of these components. While handling the fuel injector, be careful not to touch the nozzle or the pin assembly on the nozzle end.

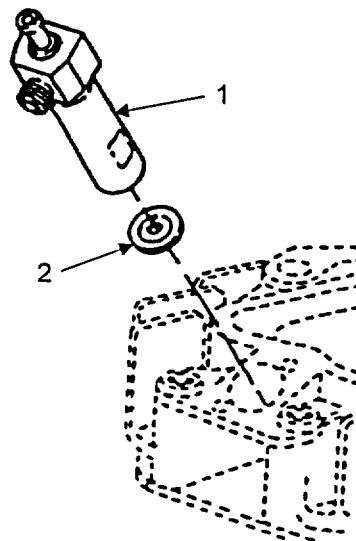

Figure 4-4. Fuel Injector

- a. Remove the injector (Figure 4-4, Item 1) from the cylinder head.
- b. Remove seal washer (2) and discard.

B. Test.

1. Conducting Test of the Injector.

- a. Visually inspect injector (1) for scoring or burning. inspect to see if injector is bent, cracked, or damaged.

NOTE

Loosen the pressure gauge connection and crank the engine until trapped air is removed from the system.

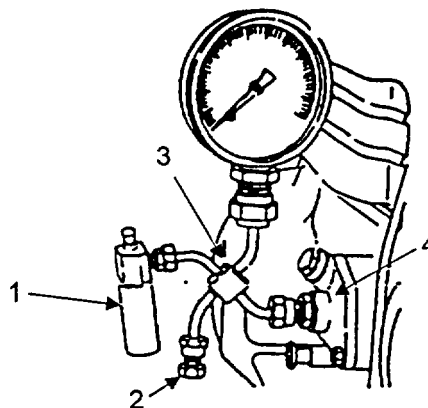

Figure 4-5. Injector Test Setup

- b. Connect testing device 60462800 (Figure 4-5, Item 3) to injector pump (4) and injector (1). Ensure side connection (2) is tightly capped.

WARNING

DEATH OR SERIOUS INJURY COULD OCCUR IF FUEL IS NOT HANDLED CAREFULLY. USE IN A WELL VENTILATED AREA AWAY FROM OPEN FLAME, ARCING EQUIPMENT, IGNITION SOURCES, HEATERS, OR EXCESSIVE HEAT. ENGINE MUST BE SHUT DOWN AND COOL BEFORE REFUELING. ALWAYS STORE FUEL IN PROPER, MARKED CONTAINERS. DO NOT SMOKE.

SERIOUS INJURY COULD RESULT FROM INJECTOR SPRAY. KEEP HANDS AWAY FROM FUEL SPRAY.

NOTE

Prior to testing injector, ensure throttle control hand lever is in the STOP position.

c. Crank engine by hand. As the engine is cranked, read fuel injection pressure on the gauge and check fuel spray pattern from the injector. Injection pressure should be 1958 to 2074 psi (135 to 143 bar). Fuel should spray out in an even spray pattern if spray is not even, replace injector. If injector nozzle drips fuel before or after it has reached recommended Injection pressure, replace the injector.

C. Install.

1. Installing the Injector

a. Be certain injector seat in cylinder is clean. Lightly coat a new seal washer (Figure 4-4, Item 2) with grease and install on nozzle end of injector (1). Make sure outside bevel edge of new joint washer points toward cylinder head.

b. Carefully install injector (1) into injector bore in cylinder head. Make sure not to damage nozzle needle. Tighten injector to 7 lb.-ft (10 Nm) using a torque wrench.

4-14 RECIPROCATING COMPRESSOR

A. INTRODUCTION. This paragraph covers maintenance and repair activities for the reciprocating compressor at the Unit Level.

4-14.1. COOLING SYSTEM.

This task covers A Replace

Tools:

Tool Kit, General Mechanic's Set

Materials/Parts

Equipment Conditions:
Compressor Secured

A. Replace

1. Replacing Cooling System Components.

a. The model CAPITANO-PD is air cooled. For maintenance procedures for the Compressor Impeller/Groove Pulley refer to paragraph 4-14.3. Intercoolers (Figure 3-7) and after coolers (the finned tube located behind the

Compressor Impeller/Groove Pulley) are also provided for the compressed air. Each of these units is replaced by unbolting the affected part and replacing it with a manufacturer's numbered part.

4-14.2. LUBRICATING SYSTEM

This task covers: A. Inspect B. Repair C. Replace

Tools:

- Tool Kit, General Mechanic's Set
- Calibrated Test Pressure Gauge

Materials/Parts:

- O-ring (P/N N07091)
- Halo Carbon Grease, NSN 9150-00-754-2760
- Equipment Conditions
- Compressor Removed and Secured

NOTE

The compressor oil pump is a non-repairable item. Inspection and venting of the pump are described in paragraph 3-14.1. In case the pump becomes inoperable, replace it as follows:

A. Replace.

1. Replacing the Lube Oil Pump (Figure 4-6).

- a. Remove oil line from bottom of oil pump.
- b. Remove three cap screws (4) and washers (3).
- c. Remove oil pump (2) and gasket (1) from compressor crankcase.
- d. Replace pump with a new one in reverse order of removal.
- e. Remove the filter mount (figure 3-7 item 14) from the crankcase pump housing to provide access to the pump drive cam.

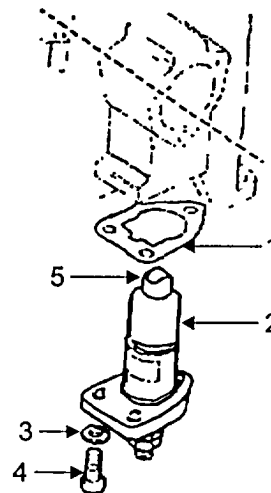

Figure 4-6. Oil Pump

- f. The actuator (5) of the pump must always be in contact with the cam.
- g. Put a 0.018 inch (0.3 mm) feeler gauge between the pump actuator (5) and the low side of cam.
- h. Turn the fan wheel by hand. This should be possible without heavy resistance.
- i. If heavy resistance is felt, install a new gasket of proper thickness. The pump actuator must always be in contact with the cam, but must not overstroke the pump.
- j. Reassemble removed components as original.

B. Inspect.

1. Inspecting the Oil Pressure Regulator.

- a. The lube oil pressure regulator is mounted on the third stage cylinder of the compressor. Oil from the lube oil pump enters the regulator at a port in the mounting flange. Oil returns to the crankcase from the regulator through

a port at the base of the second stage cylinder. A sight glass is provided at the return port. When oil pressure is properly regulated, full oil flow is visible without bubbles. Adjustment of the lube oil pressure regulator is described in paragraph 3-14.1. A plug in the top of the mounting flange provides a connection for a pressure gauge to check oil system pressure. Normal operating oil pressure is 850 psi \pm 50 psi. If proper oil pressure cannot be maintained by the regulator, the unit must be replaced.

C. Replace.

1. Replacing the Oil Pressure Regulator.

CAUTION

The regulator is internally spring loaded. Remove and disassemble with care.

- a. Remove inlet and return oil lines (Figure 4-7, Items 2 and 3). Cap or plug open ends to prevent contamination of the oil system
- b. Remove mounting socket head cap screws (1) and remove the regulator (4) and O-ring (8).
- c. Install O-ring with halo carbon grease into piston cylinder
- d. Install the regulator by attaching it to the third stage cylinder with the socket head cap screws as original.
- e. Reinstall the oil lines from the oil pump and from the second stage cylinder

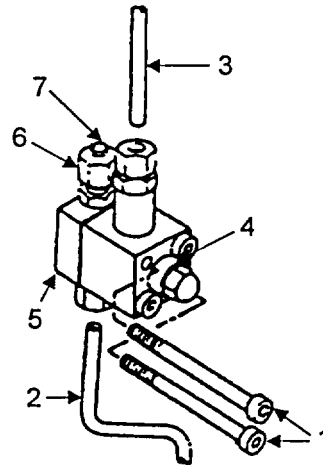

Figure 4-7. Oil Pressure Regulator

NOTE

Before the compressor is placed in service it will be necessary to check oil pressure with a suitable pressure gauge.

- f. Remove the plug (7) from the gauge port, fitting (6) in the top of flange (5).
- g. Install a calibrated test pressure gauge, suitable for testing oil pressure in the range of 700 to 1000 psi (48.9 to 69 bar). The connector (6) is for 6mm L tube.
- h. With the compressor in operation, verify that oil pressure is normal and the regulator is properly adjusted in accordance with paragraph 3-14.1.

2. Oil Lines

- a. The oil lines provided with the model CAPITANO-PD are available as assemblies. In case of damage they should be replaced as assemblies. The oil lines consist of a supply line between the oil pump and the oil pressure regulator, and a return line from the oil pressure regulator to the second stage cylinder. Each is fabricated of 6 mm OD tube, shaped to fit the configuration of the compressor. The supply line includes a filter which is an integral part of the line.

- b. Remove the selected oil line by releasing the tube end fittings and removing the oil line
- c. Cover or plug the opened fittings to avoid entry of dirt into the compressor oil system.
- d. Replace the oil line in the reverse order of removal

4-14.3. COMPRESSOR IMPELLER/GROOVE PULLEY

This task covers: A. Inspect b. Remove C. Repair D. Install

Tools

Socket Wrench, N04447

Materials/Parts:

Equipment Conditions:
 Compressor Secures.
 Belt Guard Removed

A. Inspect.

1. Inspecting the Compressor Impeller/Groove Pulley

- a. Remove the drive V-belt and clean the flywheel with a stiff brush.
- b. Inspect the belt groove. If the groove is worn so that the belt bottoms in the groove, the impeller/groove pulley must be replaced.
- c. Inspect the Impeller blades for cracks or other damage. If damage is present, replace the component.

B. Remove.

1. Removing the Compressor Impeller/Groove Pulley.

- a. Remove four socket head cap screws (1) and lock washers (2) to separate Impeller (3) from hub (4)

C. Repair.

1. Repairing the Compressor Impeller/Groove Pulley.

- a. Only minor repairs such as cleaning and removing dirt deposits and corrosion from the Impeller blades and belt groove are practical. If physical damage to the assembly exists, replace it.

D. Install

1. Installing the Compressor Impeller/Groove Pulley.

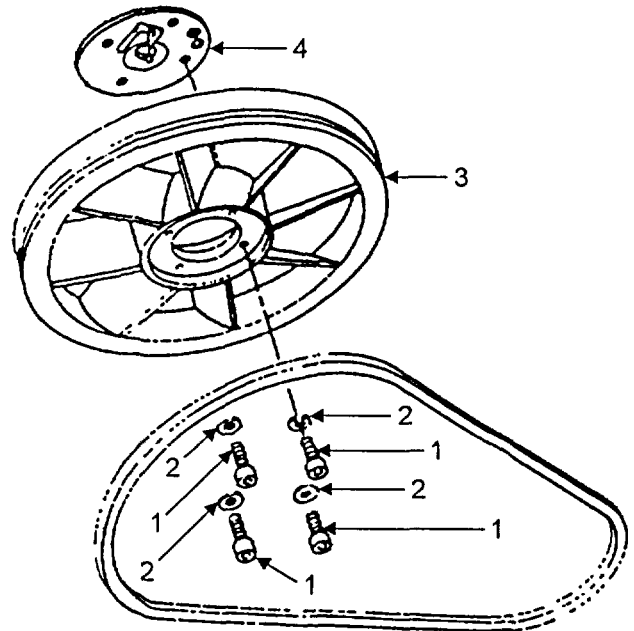

Figure 4-8. Compressor Impeller/Groove Pulley

- a. Reinstall the impeller/groove pulley in reverse order of removal.

4-14.4. VALVE HEAD ASSEMBLY, FIRST STAGE.

This task covers: A. Inspect B. Replace

Tools:

Valve Head Wrench,(P/N 004555)
Torque Wrench (P/N 6006NMA)

Materials/Parts

O-ring (P/N N02169)
Halo Carbon Grease, NSN 9150-00-754- 2760

Equipment Conditions:

Compressor Secured,
Air Pressure Purged From System

General Instructions. Observe the following instructions for all valve maintenance.

- Always replace valves as a complete set.
- Observe the correct sequence when reassembling.
- Remove and check valves in accordance with PMCS schedules.
- Tighten the screws and nuts for the valve heads and cylinders equally and in a diagonal sequence.
- Be sure that valves are cold before tightening Refer to Appendix E for torque requirements.

A. Inspect.

1. Inspecting the First Stage Discharge Valve.

a. Remove the plain cap nut (Figure 4-9, Item 3) and the gasket (4) and inspect the gasket. The gasket should be replaced if it is damaged.

b. Unscrew and remove the socket set screw (5) and the discharge valve cover (6).

c. Remove the disc spring (7) and the O-ring (8). The O-ring should be undamaged and nonporous. Replace it if necessary.

d. Extract the discharge valve assembly (9).

e. Discard the valve gasket (14) and replace it with a new one. The valve gasket must always be replaced

f. Inspect the valve seat (13). The sealing surface must be in good condition: devoid of pitting or cracking. The maximum valve seat width is 0.039" (1.0 mm).

g. Clean and inspect the valve plate (12). The maximum acceptable groove depth must not exceed 0.008" (0.2 mm).

h. Check the tolerance of the inside diameter of the valve body (10). The valve body must not show any grooves at ID 0.669"-0.673" (17.0-17.1mm).

i. The valve spring (11) is serviceable again if it shows no outside scuffing and the spring ends have not picked up on the next coil.

2. Inspecting the Intake Valve.

NOTE

To remove the first stage inlet valve, it is necessary to first remove the valve head.

- a. Remove the tube nuts, tubes and ferrules from the tube connections (Figure 4-9, Item 16 and 18) to the valve head (17) and the intake filter (not shown).
- b. Inspect the O-ring (19). Replace It If it is damaged.
- c. Unscrew and remove the socket head cap screws (15).
- d. Lift the valve head (17) from the piston cylinder.

NOTE

The valve plate (21) rests free on the piston cylinder; it is not spring operated.

B. Replace.

1. Replacing the Valves.

- a. Apply halo carbon grease to the O-ring.
- b. Place the valve plate (Figure 4-9, Item 21) and O-ring (20) into the valve seat of the piston cylinder.
- c. Install the discharge valve assembly (9) and the valve cover (6) with gasket (7) and O-ring (8). Position the set screw (5). Do not tighten set screw.

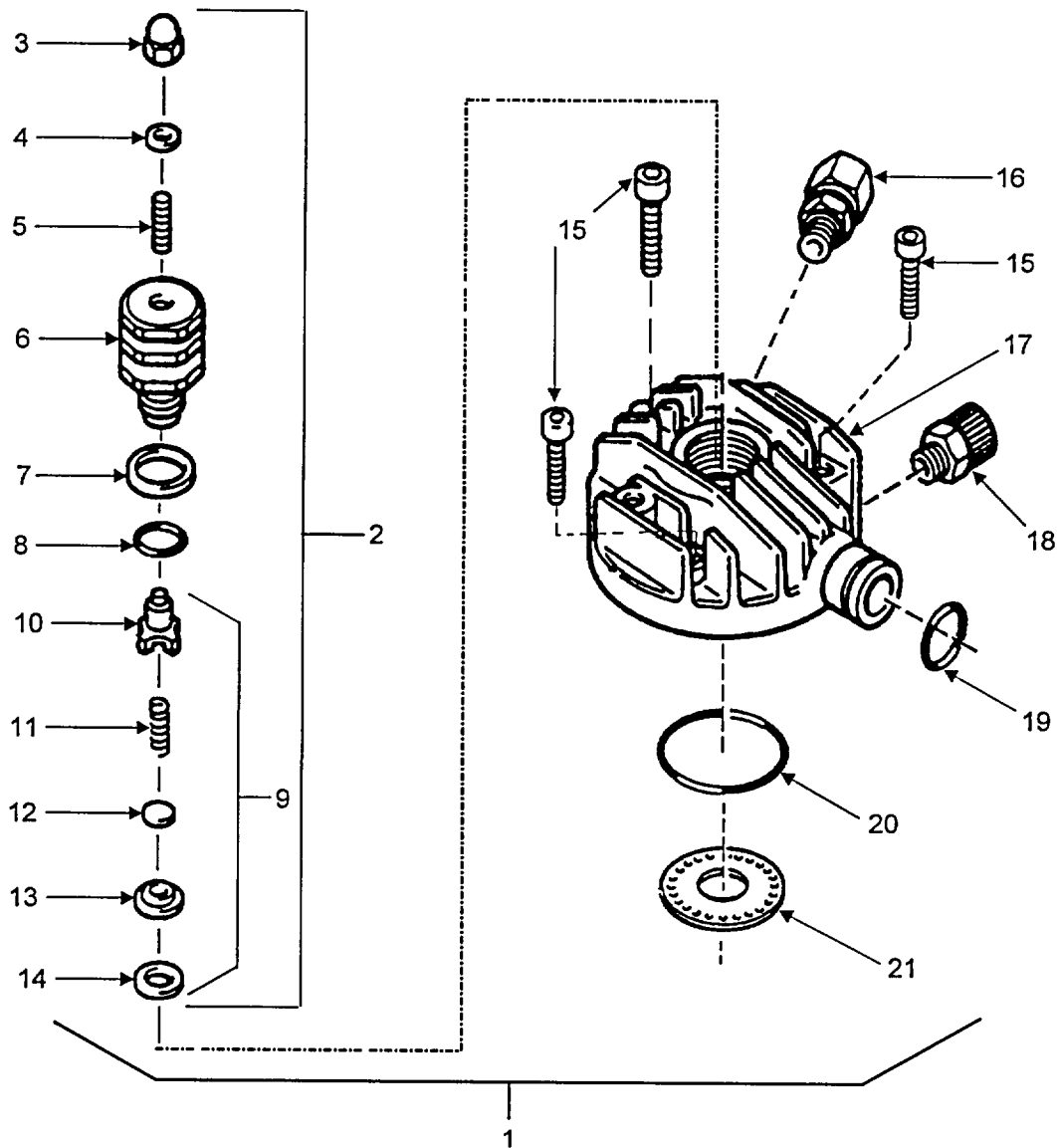

- | | | | |
|----|---------------------------------|-----|-----------------------|
| 1 | 1st Stage Valve Head Assembly | 12. | Valve Plate |
| 2 | Discharge Valve Assembly | 13. | Valve Seat |
| 3 | Plain Cap Nut | 14. | Gasket |
| 4 | Gasket | 15. | Socket Head Cap Screw |
| 5 | Set Screw | 16. | Male Connector |
| 6 | Valve Cover | 17. | Valve Head |
| 7 | Spring Plate | 18. | Plastic Connector |
| 8 | O-Ring | 19. | O-Ring |
| 9 | Discharge Valve Insert Assembly | 20. | O-Ring |
| 10 | Discharge Valve Insert | 21. | Intake Valve |
| 11 | Spring | | |

Figure 4-9. Valve Head and Valves, First Stage

- d. Torque the valve head cap screws (15) to 18 lb -ft (25 Nm) before tightening the socket set screw (5) in order to avoid damage to the valve body (10).
- e. Tighten the socket set screw (5) with the appropriate sized hex key.
- f. Position the gasket (4) and plain cap nut (3) and tighten it with an open end wrench.
- g. Reinstall the tube connections (16, 18) and the inlet connection to the valve head (17).

4-14.5. VALVE HEAD ASSEMBLY, SECOND STAGE.

This task covers: A. Inspect B. Replace

Tools:

- Valve Head Wrench (P/N 004555)
- Torque Wrench (P/N 6006NMA)

Materials/Parts:

- Gaskets
- RTV Sealant NSN 8040-00-225-4548
- Grease (Item 17) NSN 9150-00-754-2760

Equipment Conditions:

- Compressor Secured and Cold
- All Air Pressure Purged From System

A Inspect.

1. Second Stage Discharge Valve. Remove and inspect the 2nd stage discharge valve as follows:

- a. Remove the plain cap nut (Figure 4-10, Item 3) and the gasket (4). Inspect the gasket. The gasket should be replaced if damaged.
- b. Unscrew and remove the socket set screw (5) and the discharge valve cover (6).
- c. Remove the spring washer (7) and the O-ring (8). The O-ring should be undamaged. Replace it if necessary.
- d. Extract the discharge valve assembly (9).
- e. Discard the valve gasket (14) and replace it with a new gasket.
- f. Inspect the valve seat (13). The sealing surface must be in good condition: devoid of pitting or cracking. The maximum valve seat width is 0.039" (1.0 mm)
- g. Clean and inspect the valve plate (12). The maximum acceptable groove depth must not exceed 0.008" (0.2 mm).
- h. Check the tolerance of the inside diameter of the valve body (10). The valve body must not show any grooves at ID 0.669"-0.673" (17.0-17.1mm).
- i. The valve spring (11) is reusable if it shows no outside scuffing and the spring coils are not touching.

2. Removing the 2nd Stage Inlet Valve. To remove the 2nd stage inlet valve, it is necessary to first remove the valve head. Proceed as follows:

- a. Remove the tube nuts, tubes and ferrules from the tube connections (Figure 410, Item 18) to the valve head (19)
- b. Unscrew and remove the socket head cap screws (15)
- c. Lift the valve head off the piston cylinder.
- d. Unscrew the valve cover (23) from the bottom of the valve head (19) using the valve wrench

B. Replace

1. Reassembly of the 2nd Stage Valve Head and Valves

- a. To reassemble the valve head and valves, refer to figure 4-10 and proceed as follows.
- b. Before fitting the inlet valve to the valve head, grease the Inlet valve plate (12) slightly and place it correctly on the valve seat to make reassembly easier.
- c. After having assembled the inlet valve,peen the valve head twice, once on each side of the valve, to lock the threads in place.
- d. Apply a temperature-resistant, non-age-hardening RTV sealing compound to the sealing surface of the valve head.
- e. Torque the valve head cap screws (15) to 18 ft-lb (25 Nm) in accordance with the sequence shown in Appendix G **before** tightening the socket set screw (5) in order to avoid damage to the valve body (10)
- f. Tighten the socket set screw (5) with the appropriate size Hex head wrench
- g. Position the gasket (4) and plain cap nut (3) and tighten it with an open end wrench
- h. Reinstall the tube connections (18) to the valve head (19).

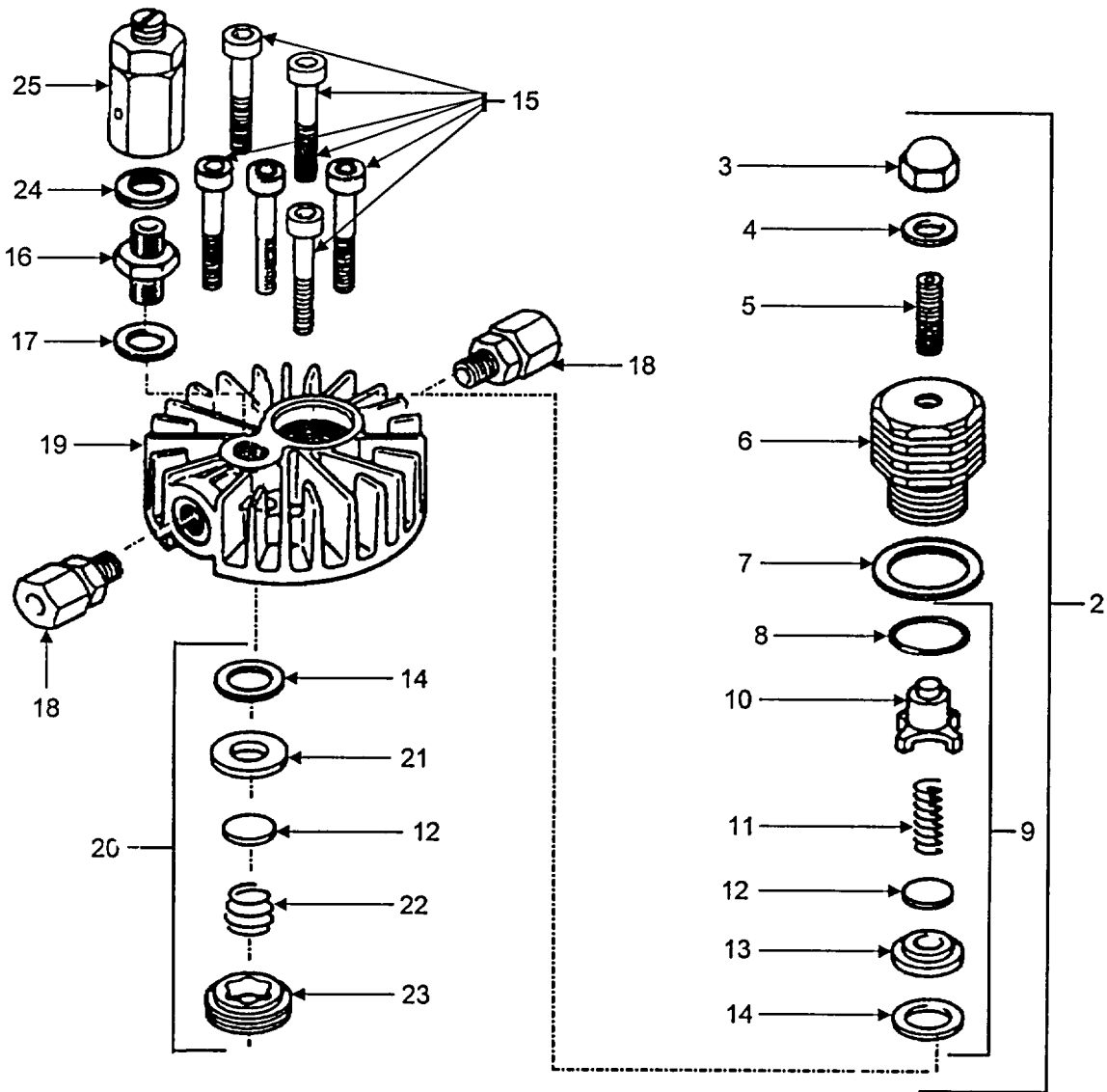

- | | | | |
|----|---------------------------------|-----|--------------------------|
| 1 | Valve Head Assembly | 13. | Valve Seat |
| 2 | Discharge Valve Assembly | 14. | Gasket |
| 3 | Plain Cap Nut | 15. | Socket Head Cap Screw |
| 4 | Gasket | 16. | Male Connector |
| 5 | Set Screw | 17. | Gasket |
| 6 | Valve Cover | 18. | Male Connector |
| 7 | Spring Plate | 19. | Valve Head, Second Stage |
| 8 | O-Ring | 20. | Inlet Valve Assembly |
| 9 | Discharge Valve Insert Assembly | 21. | Valve Seat |
| 10 | Discharge Valve Insert | 22. | Inlet Valve Spring |
| 11 | Spring | 23. | Inlet Valve Cover |
| 12 | Valve Plate | 24. | Gasket |
| | | 25. | 1st Stage Safety Valve |

Figure 4-10. Valve Head and Valves, Second Stage

4-14.6. VALVE HEAD ASSEMBLY, THIRD STAGE

This task covers' A Remove B Inspect C Install

Tools:

- Valve Head Wrench (PIN 004555)
- Torque Wrench (P/N 6006NMA)

Materials/Parts:

- O-ring (P/N N02789)
- Halo Carbon Grease, NSN 9150-00-754-2760
- Gasket (P/N N03625)

Equipment Conditions:

- Compressor Secured and Cold
- All Air Pressure Purged From System

A Remove.

1. Removing the 3rd Stage Discharge Valve Remove the 3rd stage discharge valve for inspection as follows:

NOTE

The discharge valve (Figure 4-11, Item 8) is inserted into the valve head (10) It is sealed by an O-ring (7) and fixed to the valve head with a set screw (4)

- a. Remove the plain cap nut (Figure 4-11, Item 2) and the gasket (3). Unscrew the socket set screw (4) three or four turns If the gasket is damaged, replace it with a new gasket
- b. Remove the socket head cap screws (5) that secure the valve head (10), then remove the valve head cover (6).
- c. Place two screwdrivers into the groove of the discharge valve body and lift out the discharge valve (8) together with the O-ring (7). If necessary, loosen the valve first, using a 13 mm open-end wrench on the flat surfaces

2. Removing the Inlet Valve.

- a. Remove the tube connections to the valve head (10).
- b. Unscrew and remove the socket head cap screws (5).
- c. Remove the valve head cover (6).
- d. Extract the inlet valve (13) using the valve tool provided with the unit.

B Inspect

1. Inspecting the Discharge Valve.

- a. Check the O-ring. It should be undamaged and not torn. Replace it if necessary.
- b. If the discharge valve does not close tightly, It should be replaced. The bore diameter of the valve seat should be 4 0 mm

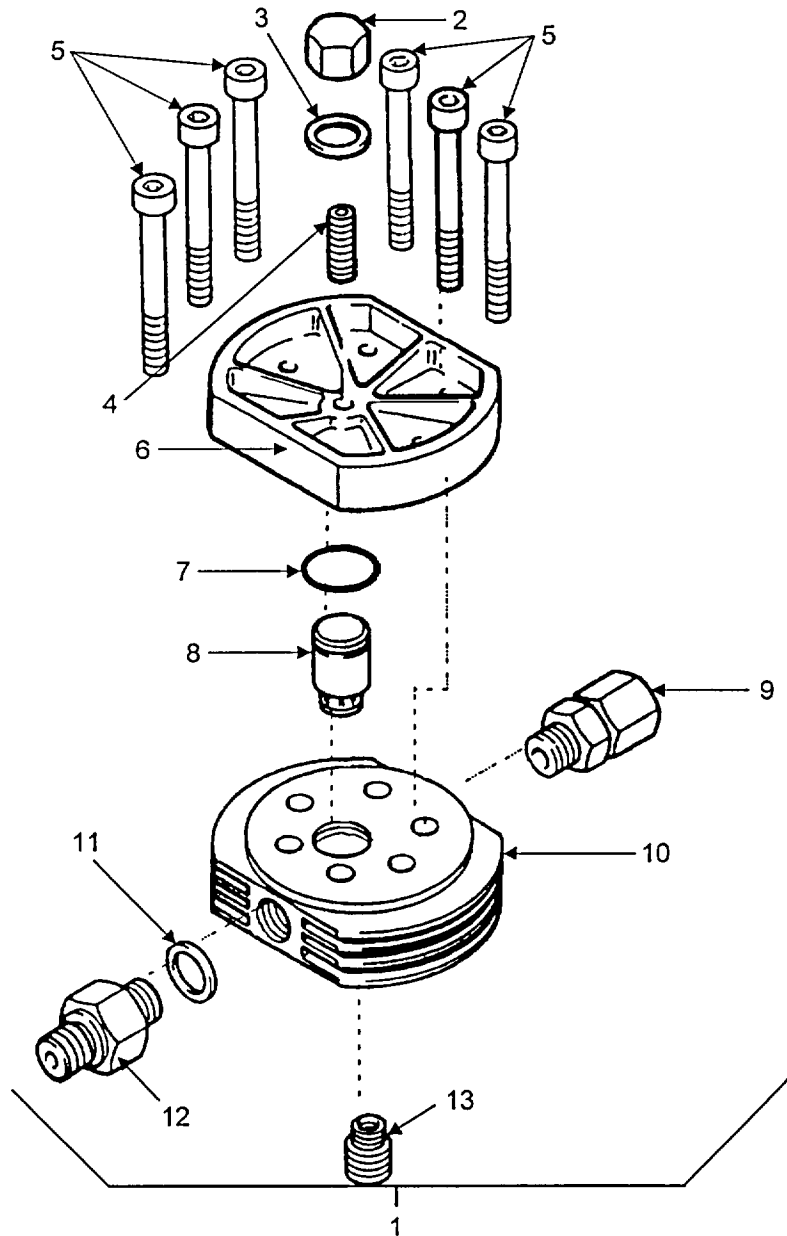

- | | | | |
|---|-----------------------|-----|--------------------------|
| 1 | Valve Head Assembly | 7 | O-Ring |
| 2 | Plain Cap Nut | 8 | Discharge Valve Assembly |
| 3 | Gasket | 9. | Male Connector |
| 4 | Socket Set Screw | 10. | Valve Head |
| 5 | Socket Head Cap Screw | 11. | Gasket |
| 6 | Valve Head Cover | 12. | Adapter |
| | | 13. | Intake Valve Assembly |

Figure 4-11. Valve Head Assembly, Third Stage.

2. Inspecting the Inlet Valve

- a. Check all parts for condition and acceptable measurements. Refer to Table 4-1 for wear limits.
- b. The inlet valve should be replaced if it no longer closes tightly. The bore diameter of the valve seat should be 4.0 mm.

C Install

1. Installing the Valves. Reassemble the 3rd stage valves and valve head using replacement parts as needed. Proceed as follows:

- a. Reinstall the intake valve (Figure 4-11, Item 13) in the reverse sequence of its removal
- b. Insert the discharge valve (8) with the O-ring (7) into the valve head (10).
- c. Position the valve head cover (6) Do not use a sealing compound on the third stage valve head.
- d. Insert and torque the valve head cap screws (5) to 18 lb.-ft (25 Nm = 2.5 kgm) in a diagonal sequence before tightening the socket set screw (4) in order to avoid damage to the valve head cover (6).
- e. Screw in the set screw (4) with hex key. Fit the gasket (3) and the plain cap nut (2) and tighten with an open end wrench.
- f. Reinstall the tube connections to the valve head (10).

Table 4-1. Compressor Repair Data

Stage	Item	Max.		min	
		in	mm	in	mm
First	Discharge valve spring length.	0.945	24	0.827	21
	Discharge valve stroke.	0.049	1.25	0.039	1
	Valve seat bore diameter	0.049	1.25		
Second	Discharge valve spring length	0.945	24	0.827	21
	Discharge valve stroke	0.041	1.05	0.031	0.8
	Discharge valve seat bore	0.315	8		
	Inlet valve spring length	0.413	10.5	0.354	9
	Inlet valve stroke	0.049	1.25	0.039	1
Third	Inlet valve seat bore	0.492	12.5		
	Discharge valve seat bore	0.157	4		
	Inlet valve stroke	0.047	1.2	0.031	0.8
	Discharge valve stroke	0.047	1.2	0.035	0.9

4-14.7. REPLACE COMPRESSOR

This task covers A Remove B Install

Tools:

Tool Kit, General Mechanic's Set
 Shop Equipment, Automotive
 Maintenance and Repair
 Suitable Lifting Device to Handle
 100 lb.

Materials/Parts:

Replacement Compressor (P/N KC-FH US GOV'T)
 Distilled Water NSN 6810-00-297-9540
 Non-ionic Detergent NSN 7930-00-282-9699

Equipment Conditions:

Unit Shut Down
 Pressure Purged From System
 Engine and Compressor Sections Separated

A Remove.

1. Removing the Compressor.

- a. Remove the pressure lines between compressor and all components (gauge panel, purification system, etc.).
- b. Attach a suitable lifting strap to the intercoolers on both sides of the compressor. The compressor weighs approximately 77 lb.(35 kg).
- c. Remove the hold-down screws securing the compressor to the frame and lift the compressor out of the frame.
- d. Install plugs or closures to open tubing.

B Install.

1. Installing the Compressor.

- a. Attach the lifting strap to the new compressor. Lift compressor high enough to clear frame then lower into frame.
- b. Align compressor mounting holes to the holes in the frame and secure with mounting bolts.
- c. Remove closure fittings as necessary and connect the tubing to the new compressor.
- d. Leak test all connections under pressure, using non-ionic detergent solution.

4-15. FUEL FILTER.

This task covers A. Replace

Tools:

Tool Kit, General Mechanic's Set

Materials/Parts:

Tape, Masking NSN 7510-00-283-0612
Filter, Fuel P/N 00329102

Equipment Conditions:

Unit Must Be Cool:
Fuel Tank Empty
Well Ventilated Area

A. Replace.

1. Removing the Fuel Filter.

a. Disconnect gravity feed line (Figure 4-12, Item 1) at the pump end and drain fuel tank into a suitable container. Reconnect fuel line (1) to pump

b. Remove banjo bolt (2) and ring piece (3) and washers (4) Apply closures to open end of fuel line.

c. Remove four cap screws (5) from filter mounting plate (6). Remove and discard fuel filter assembly (7).

2. Installing the Filter.

a. Remove closures from fuel lines and replace fuel filter with new part in reverse order of removal

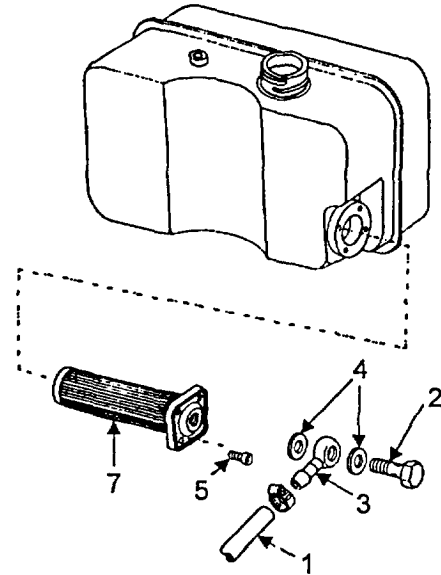

Figure 4-12. Fuel Filter

4-16. PURIFICATION CYLINDER.

This task covers: A. Replace

Tools:

Tool Kit, General Mechanic's Set
7/16" Deep Well Socket

Materials/Parts:

Non-ionic Detergent, NSN 7930-00-282-9699
Distilled Water, NSN 6810-00-297-9540

Equipment Conditions:

Compressor Secured
Pressure Purge From System

A. Replace

1. Replacing the Purification Cylinder.

NOTE

Replace the purification cylinder with an identical unit only.

- a. Purge all pressure (paragraph 2-3) from the system by opening purge valve.
- b. Disconnect inlet and outlet air lines from the bottom of the cylinder.

- c. Release T-bolt clamps which secure the cylinder to its mounting bracket. Remove hole plugs.
- d. Install a replacement unit in reverse order of removal.
- e. Install a purification cartridge in the cylinder per paragraph 3-16.2 and start the compressor.
- f. Test all air line connections with a non-ionic detergent solution to ensure the system is leak free.

4-17. OIL/WATER SEPARATORS.

This task covers: A. Replace

Tools:

Tool Kit, General Mechanic's Set

Materials/Parts:

Non-ionic Detergent, NSN 7930-00-282-9699

Distilled Water, NSN 6810-00-297-9540

Equipment Conditions:

Compressor Secure

Pressure Purge From System

A Replace.

- 1. Replacing the Oil/water Separators.

NOTE

The system includes two oil/water separators. One is installed between the second and third stages and is referred to as the intermediate filter (Figure 1-2, Item 10). The second or final oil/water separator (Figure 1-2, Item 8) is installed after third stage and before the purification cylinder. Both separators are fitted with safety relief valves and manual condensate drain valves. Each separator is replaced with the manufacturer's corresponding numbered part using the following steps:

- a. Open the purge valve and release all air pressure from the system (paragraph 23).
- b. Disconnect the air lines from the unit and remove the unit from its mounting bracket by releasing the U-bolt clamps that secure it to the mounting bracket.
- c. Remove the safety relief valve and manual drain valve from the separator.
- d. Replace the oil/water separator in reverse order of removal. Leak test all connections with nonionic detergent solution.

WARNING

THE FINAL OIL/WATER SEPARATOR IS SUBJECT TO DYNAMIC LOADING. IT IS DESIGNED TO OPERATE FOR UP TO 90,000 HOURS. AFTER REACHING THE MAXIMUM NUMBER OF HOURS, THE FINAL OIL/WATER SEPARATOR SHOULD BE REPLACED. FAILURE TO FOLLOW THIS WARNING MAY RESULT IN PERSONNEL INJURY, DEATH OR DAMAGE TO EQUIPMENT.

4-18. PRESSURE MAINTAINING VALVE.

This task covers. A Adjust B. Replace

Tools:

Tool Kit, General Mechanic's Set

Materials/Parts:

Non-ionic Detergent, NSN 7930-00-282-9699
 Distilled Water, NSN 6810-00-297-9540

Equipment Conditions:

Compressor Operational
 Pressure Purged From System

NOTE

The setting of the PMV at the factory is 2000 psi (138 bar)..

A Adjust

1. To determine if the Pressure Maintaining Valve PMV is properly adjusted:

a. Depressurize the final separator and purification chamber by slowly opening the manual purge valve.

b. Close the purge valve and then start the compressor with the delivery valve open.

c. Observe the final pressure and note the pressure at which the PMV opens (air is delivered) If the pressure is not within 2000 ± 200 psi ($138 + 14$ bar), readjust the PMV.

d. To readjust the pressure setting loosen the locking ring (Figure 4-13, Item 2), and using a hex key, turn adjusting screw (1) clockwise to increase pressure, counter-clockwise to reduce pressure

B. Replace.

1. Replacing the PMV.

a. Open the purge valve and release all air pressure from the system (paragraph 23)

b. Disconnect the air lines from the PMV and install a new unit in its place. Soap test all fittings for leaks

c. Adjust new valve as in steps 1, a through c.

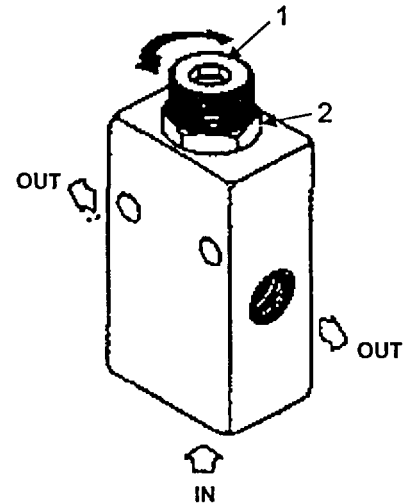

Figure 4-13. PMV

4-19. INTERSTAGE PRESSURES.

This task covers, A Check B Install C. Test

Tools:

Tool Kit, General Mechanic's Set
 Pressure Gauge, Test (P/N 057491)
 Pressure Gauge, Test (P/N 057492)

Materials/Parts:

Cloth, Lint-free NSN 7920-00-044-9281
 Detergent, Non-ionic NSN 7930- 00-282-9699
 Water, Distilled NSN 6810-00-297-9540

Equipment Conditions:

Unit Shut Down

Pressure Purged From System

A Check.

1. Checking the Interstage Pressure Readings.

- a. Remove dust from test port connectors with a lint-free cloth.
- b. Remove tube plugs and install appropriate pressure gauges in test ports.
- c. Operate the unit and observe pressure readings should be approximately 56 psi (4 bar) at first stage, 50psi (35 bar) at 2nd stage.
- d. If pressures are incorrect refer to Unit Troubleshooting Section IV

B Install.

1. Installing the Tube Plugs.

- a. Remove test gauges and reinstall tube plugs.

C Test.

1. Testing the Interstage Connections.

- a. Leak test with detergent/water solution .

4-20. TUBING AND FITTINGS.

This task covers: A. Replace B Test

Tools:

Materials/Parts:

- Cloth, Lint-free NSN 7920-00-044-9281
- Detergent, Non-ionic NSN 7930-00-282-9699
- Tape, Teflon NSN 8030-00- 889-3534
- Water, Distilled NSN 6810-00-297-9540

Equipment Conditions:

- Unit Shut Down
 - Pressure Purged From System
-

A Replace

1. Replacing Tubing and Fittings.

- a. Remove dust with lint-free cloth from tube connections.
- b. Unscrew tube nuts/fittings of defective tube.
- c. Install new tube or fittings, use Teflon tape on pipe threads.

B. Test.

1. Testing Tube Connections

- a. Leak test with detergent/water solution.

Section VI. PREPARATION FOR STORAGE OR SHIPMENT

Paragraph		Page
4-21	Preparation for Shipment	4-33
4-22	Storage Requirements	4-33
4-23	Preparation for Storage	4-33
4-24	Preservation	4-34
4-25	Preventive Maintenance During Storage	4-35
4-26	Reactivation After Storage	4-35

4-21. PREPARATION FOR SHIPMENT.

The model CAPITANO-PD can be shipped complete with both drive and compressor units or each section can be shipped separately. In either case it is necessary to remove the hour meters from the HOURMETER ON brackets and place them in the HOURMETER OFF brackets. This is necessary to preserve an accurate log of real operating time. If the engine and compressor sections are to be shipped together, ensure that the clamp devices are securely fastened. Drain the fuel tank. Provide a safe means of securing the unit in the transportation vehicle to avoid damage or potential personnel injury from load shifting.

4-22. STORAGE REQUIREMENTS.

- a. Ensure that the compressor is kept indoors in a dry, dust-free room
- b. Store the unit indoors, with its tarpaulin cover over it
- c. Store where no water can form under the unit or collect in low areas of the tarpaulin

NOTE

If this procedure cannot be followed, or if the compressor will be out of service for more than 24 months, contact the manufacturer's Service Department for special instructions appropriate for the particular storage circumstances.

4-23. PREPARATION FOR STORAGE.

a. If the model CAPITANO-PD will be out of service for several months, it should be preserved in accordance with the following instructions. Prior to preserving the compressor unit, it must be run until warm, i.e., up to the specified service pressure. Operate the unit for approximately 10 minutes, then carry out the following steps:

1. Check all pipes, filters and valves (including safety relief valves) for leakage
2. Tighten all couplings, as required.
3. After 10 minutes, open the outlet valve and operate the compressor at 2000 psi (138 bar) using the pressure maintaining valve for approximately 5 minutes.
4. After the 5 minutes, shut the compressor unit down and completely drain all separators and filters. Close all valves.

5. Remove filter heads and lubricate the threads with halo carbon grease and reinstall filter heads.

CAUTION

To prevent oil from entering the outlet lines as a result of preservation procedures, ensure that filter elements remain in the filters.

6. Remove the intake filter/intake pipe completely and seal openings.

4-24. PRESERVATION.

4-24.1. PRESERVING THE COMPRESSOR.

- a. Operate the compressor again and slowly spray approximately 0.35 oz. (10 cc) of MIL-L-17331 compressor oil into the inlet port while the compressor is running.
- b. Keep the delivery valve open and the condensate drain valves closed. After spraying the oil into the inlet port, run the compressor unit for an additional 5 minutes before shutting the compressor unit down.
- c. Close the delivery valve.
- d. Close the inlet port with a dust cap and/or tape.

4-24.2. PRESERVING THE ENGINE.

- a. Drain crankcase oil Then fill crankcase to operating level with MIL-L-21260 preservative lubricating oil, Grade 2.

WARNING

DEATH OR SERIOUS INJURY COULD OCCUR IF FUEL IS NOT HANDLED CAREFULLY. USE IN A WELL VENTILATED AREA AWAY FROM OPEN FLAME, ARCING EQUIPMENT, IGNITION SOURCES, HEATERS, OR EXCESSIVE HEAT. ENGINE MUST BE SHUT DOWN AND COOL BEFORE REFUELING. ALWAYS STORE FUEL IN PROPER, MARKED CONTAINERS DO NOT SMOKE.

- b. Remove fuel tank cap and hose connection to bottom of tank Collect fuel in a suitable metal container.
- c. Replace fuel filter.
- d. Reconnect hose to bottom of fuel tank and pour approximately one pint of MIL-L46002 preservative oil, Grade 1, into fuel tank.
- e. Start engine and allow to operate for not less than 5 to 7 minutes. Shut down engine.
- f. Drain engine crankcase and fuel tank into suitable metal container.
- g. Service air cleaner in accordance with paragraph 3-15.2.

4-25. PREVENTIVE MAINTENANCE DURING STORAGE.

Operate the compressor once every three months as follows:

- a. Remove the dust cap from the inlet port and install the inlet filter.
- b. Open the discharge valve and allow the system to run approximately 5 minutes until there is outflow from the valve and oil is visible in the sight glass of the oil regulating valve.
- c. Shutdown the compressor.
- d. Open the condensate drain valves, depressurize the unit then close the drain valves again
- e. Remove the intake filter and replace the dust cap on the inlet port.

4-25.1. LUBRICATION OILS FOR PRESERVATION.

After prolonged storage periods, the oil will age in the compressor. The oil must be drained at least every 36 months and replaced with fresh preservative oil. The stated period can only be attained when the crankcase is sealed during the preservation period in accordance with the preservation requirements.

- a. After changing the oil, the compressor must be operated according to the instructions above.
- b. Check the lubrication of the compressor in accordance with section 4 during the every-three-month brief operation or when turning the compressor.

4-26. REACTIVATION AFTER STORAGE.**4-26.1. COMPRESSOR UNIT.**

- a. Remove the dust cap from the inlet port and install the intake filter.
- b. Check the oil level of the compressor. If necessary, change the oil and oil filter.
- c. For units with a filter system, change all filter cartridges.
- d. Run the compressor with open discharge valve for approximately 5 minutes. Check for proper operation of the lubricating system.
- e. After 5 minutes, close discharge valve and run the system up to final pressure until the final pressure safety relief valve vents.
- f. Check the 1st and 2nd stage safety relief valves for leakage (Figure 3-7).
- g. Establish the cause of any faults from the troubleshooting table, Table 3-1 and remedy.
- h. Stop the unit when it is running properly. The compressor is then ready for operation.

4-26.2. ENGINE UNIT.

Drain preservative oil from crankcase and fuel tank. Restore engine to operating condition as for a new unit. Refer to Chapter 2, Section III.

Section VII. CLEANING PROCEDURES

Paragraph		Page
4-27	General	4-36
4-28	Determining System Cleanliness	4-36
4-29	Clean Area	4-36
4-30	Removing and Installing System Components or Piping	4-36
4-31	Pre-cleaning of Components or Piping	4-37
4-32	Cleaning Method - Non-ionic Detergent	4-37
4-33	Hydrocarbon Inspection and Analysis	4-37
4-34	Documentation and Record Keeping	4-38

4-27. General.

This section covers the cleaning procedures for diving life support air systems. The importance of maintaining a diver's air breathing system in a clean and operable condition cannot be over emphasized. This procedure provides basic steps and methods for removing and installing components and piping, and provides the simplified methods for cleaning small components, pipes and hoses for air systems, and methods for cleaning soft goods.

4-28. Determining System Cleanliness.

A periodic inspection of the air system will verify system cleanliness. If a system is suspected of contamination samples may be taken to determine the level of system cleanliness.

4-29. Clean Area.

All cleaning of life support air systems to be performed on components and piping shall be cleaned in a "clean area." This is an area isolated from oil, grease, paper, lint particles and other airborne contaminants. It shall be as free as possible of dust and debris. Work benches shall be covered with easily cleaned surfaces such as stainless steel, synthetic rubber vinyl linoleum or Formica. Floor shall be non-dusting Walls and ceiling shall be covered with washable vinyl, latex paint, or polyurethane-based paint.

4-30. Removing and Installing System Components or Piping.

The following steps are guidelines for the removal and installation of piping or components from or into a clean system. In general, common sense and clean work habits must prevail at all times to maintain system cleanliness. prior to the removal of any component or pipe, the appropriate maintenance forms are to be completed and approved.

4-30.1. Removal

Extreme care shall be used in the removal of any component or pipe from a clean system to avoid introducing any contamination. To eliminate any chance of contamination, the following steps shall be adhered to.

1. Secure the system by closing valves and controls both up and down stream of the component being removed. The system shall be tagged to ensure that the system will not be pressurized.
2. Removal of all debris such as dust, dirt, loose paint, and grease. This includes cleaning the component being removed as well as any adjacent components which may cause contamination.
3. Wipe all external surfaces of component with detergent or alcohol solvent to remove grease or dirt.
4. All personnel shall have clean hands.
5. All tools used in the removal must be clean and grease-free.
6. Remove component or piping.
7. Immediately bag or seal all exposed ends of system with plastic.

4-30.2. Installation or Reinstallation.

1. The new component or cleaned pipe shall be wrapped or double bagged. If not, the item shall be returned for cleaning.

2. The component or piping shall be removed from bagging and shall be inspected for damage at the mating surfaces, threads, or connecting surfaces and any primary surface. Inspect for dust or minor particle contamination, and remove with a lint-free rag 3 Mating components and pipes shall have protection materials or plugs removed.

4. Mating surfaces, preformed packings and threads shall be lightly coated with an approved lubricant. Threaded surfaces must be coated to prevent galling of threads at assembly.

A pressure test shall be performed to verify that there are no leaks and that the correct fittings have been installed in the system

4-31. Pre-Cleaning of Components or Piping.

Upon receipt of new components not cleaned or components or piping removed from the system for cleaning, the item shall be pre-cleaned. Doing this shall prepare the component for final cleaning. Pre-cleaning will be accomplished in an area separate from the clean area This precleaning will include but is not limited to the following'

1. All wrapping shall be removed.
2. Loose paint, rust, brackets, panels, tags, supports, and other such items shall be removed.
3. If hydrocarbons and other contaminants are known to have been introduced into the component or piping, a through degreasing procedure shall be initiated
4. Visually inspect the pre-cleaned articles under bright light to ensure that all gross contamination has been removed.
5. Bag all components and ends of pipes with plastic to await cleaning.

4-32. Cleaning Method - Non-Ionic Detergent.

This method outlines the cleaning procedures for oil-free cleaning of metallic/non-metallic components or assemblies using non-ionic detergent This procedure is only to be used if there is no equipment available to conduct the TSP cleaning method.

4-32.1. Cleaning Components or Assemblies (Excluding Hose Assemblies)**CAUTION**

Chemical protective gloves should be worn to prevent skin irritation from detergent and hot water.

- a. Disassemble components down to the smallest parts Separate soft goods and clean as specified in paragraph 4-34,
- b. Clean each component by scrubbing with non-ionic detergent solution 1/2 teaspoon (2.4 ml) detergent to 1 gallon (3 81) water using a nylon bristle brush and clean cloths.
- c. Rinse with distilled water at 125 degrees F (54 degrees C) until effluent shows no visible signs of detergent
- d. Collect some of the water rinsed over the items, in a flask that can be fitted with a rubber stopper. Shake the flask for a few seconds and if any bubbles form and remain on the surface of the water In the flask, continue to rinse item until further shake tests have no bubbles forming and remaining on the surface of the water.
- e. Purge with dry, oil-free nitrogen until visually dry, or allow to air dry. Date and sign a record containing the identification of the parts cleaned and the results of the shake test.
- f. Reassemble Items in reverse order of disassembly
- g. Double bag all components in plastic and close securely.

4-32.2. Cleaning Hose Assemblies

- a. Clean hose assemblies in accordance with the following steps, using the specific materials and utilizing proper equipment. Pre-clean hose assemblies outside the clean area by rinsing externally with distilled water.
- b. Most hose assemblies will not lend themselves to disassembly. Disassemble to the maximum extent without removing fitting or clamps.
- c. The cleaning solution shall be made by adding 1/2 ounce (14.7 ml) non-ionic detergent to 80 gallons (302.81) of distilled water.
- d. Heat the cleaning solution to 120 degrees F (49 degrees C) and circulate through the hose assembly for thirty minutes at a flow rate of not less than 1 gallon (3.81) per minute.
- e. Rinse the hose assembly with distilled water heated to 125 degrees F (52 degrees C) for 30 minutes minimum at a flow rate of not less than 1 gallon (3.81) per minute. Do not recirculate the water.
- f. Perform a shake test by collecting a 1000 ml sample of the rinse water in a flask that can be fitted with a rubber stopper. Shake the flask for a few seconds and if any bubbles form and remain on the surface of the water in the flask, continue to rinse hose until further shake tests have no bubbles forming and remaining on the surface of the water.
- g. Purge hose assembly with clean, dry, oil-free nitrogen (preferably heated to 200 degrees F (93 degrees C) until all visible signs of water are absent. Continue drying process for 1 to 2 hours after initial purge.
- h. After drying, cover each hose end with a clean plastic bag to maintain internal cleanliness. Secure the bag with tape.
- i. When components and systems have been reassembled an air sample shall be taken to verify cleanliness.

4-33. Hydrocarbon Inspection and Analysis

a. Visual Method Visibly clean is defined as the absence of all particulate and nonparticulate matter visible to the normal, unaided (except for corrected vision) eye. Particulate is defined as matter of miniature size with observable length, width and thickness. Non-particulate is film matter without definite dimension. Visual inspection may be performed by:

A clean cloth placed over the discharge end may collect particulates when air or nitrogen blown through the system.

A component has been in service and has visible signs of grease, dirt, etc.

A surface wipe with a clean filter paper results in the absorption of oil or grease.

b. Hydrocarbons exhibit fluorescence when exposed to ultra-violet light therefore passing an ultra-violet light over a components surface or the agitated cleaning solution may detect the presence of any remaining hydrocarbons.

4-34. Documentation and Record Keeping.

A diving system must retain records and documents to substantiate safety standards. A sequential record of components cleaned and tested under this procedure should be maintained by the unit doing the cleaning.

CHAPTER 5

DIRECT SUPPORT MAINTENANCE INSTRUCTIONS

	Page
Section I Repair Parts, Special Tools; Test Measurement and Diagnostic Equipment (TMDE), and Support Equipment	5-1
Section II Direct Support Maintenance Instructions	5-1

Section I. REPAIR PARTS; SPECIAL TOOLS; TEST MEASUREMENT AND DIAGNOSTIC EQUIPMENT (TMDE); AND SUPPORT EQUIPMENT

	Page
Paragraph	
5-1 Common Tools and Equipment	5-1
5-2 Special Tools (TMDE), and Support Equipment	5-1
5-3 Repair Parts	5-1

5-1. COMMON TOOLS AND EQUIPMENT.

For authorized common tools and equipment, refer to the Modified Table of Organization and Equipment (MTOE) applicable to your unit

5-2. SPECIAL TOOLS, TMDE, AND SUPPORT EQUIPMENT.

Refer to Repair Parts and Special Tools List (RPSTL) TM-5-4310-393-24P and the Maintenance Allocation Chart pertaining to direct support maintenance for the CAPITANO-PD Reciprocating Compressor Unit.

5-3. REPAIR PARTS.

Repair parts are listed and illustrated in the Repair Parts and Special Tools List. TM 5-4310-393-24P for this equipment

Section II. DIRECT SUPPORT MAINTENANCE INSTRUCTIONS

	Page
Paragraph	
5-4 General	5-1
5-5 Operating Parameters and Tolerances	5-1
5-6 Diesel Engine	5-7
5-7 Instruments - Gauges	5-51
5-8 Frame Assembly	5-52

5-4. GENERAL.

This chapter will describe maintenance to be performed on the engine and compressor assemblies beyond authorized capability of lower levels This chapter contains maintenance at the Direct Support Level as authorized by the Maintenance Allocation Chart (MAC)

5-5. OPERATING PARAMETERS AND TOLERANCES.

This section will contain an itemized list of manufacturer's specifications, sizes, and tolerances required for the CAPITANO-PD Reciprocating Compressor Unit

5-5.1. ENGINE EQUIPMENT.

Table 5-1. General Engine Data

Item	Data
Type	E 673 LHK
Total piston displacement	17.09 cu. in. (280 cu. cm.)
Working cycle	Four stroke, air cooled
Combustion system	Direct Injection
Bore	2 874 in (73 mm)
Stroke	2 6387 in (67 mm)
Weight of engine	106 lb. (48 kg)
Direction of rotation (when facing flywheel)	CCW
Rated speed (max.)	3600 rpm
Idle speed	750 to 800 rpm
Compression ratio	19.1
Compression pressure	294-412 psi (20-28 bar)
Tappet clearance	0 004 in (0.1 mm)

Table 5-2. Fuel Injection System

Item	Data
Injection nozzle.	DNO SD21
Injection operating pressure.	1956 + 117 psi (135 + 8 bar)
Injection pressure in new condition.	2021 + 118 psi (139 + 8 bar)

Table 5-3. Engine Repair Data

Item	Size (In)	Size (mm)	Max. Perm. Wear (in)	Remarks
Cylinder Head				
Bumping clearance.	0.0216/ 0.0255	0.55/ 0.65		As required between cylinder and crankcase.
Cylinder head gasket thickness	0.0157/ 0.0197	0.4/0.5		Use only one cylinder head gasket with the required thickness.
	0.0236/ 0.0276	0.6/0.7		
	0.0315	0.8		
Tappet clearance, cold. (20 ± 10 deg. C)	0.004	0.10		
Inlet valve stem diameter.	0.2740/ 0.2736	6.96/ 6.95	0.002	
Exhaust valve stem diameter	0.2740/ 0.2736	6.96/ 6.95	0.002	
Inlet valve head diameter	1.197/ ± 0.004	30.4/ ± 0.1		

Item	Size (In)	Size (mm)	Max. Perm. Wear (in)	Remarks
Exhaust valve head diameter	1.197/ ± 0.004	30.4/ ± 0.1		
Valve clearance.	.0350/ .0177	0.9/0.45		Attention: Valve clearance must not be less than 0.018 in (0.45 mm) otherwise there is danger of valve head touching the piston. The cylinder head can be machined up to a max. of .0196 in (0.5 mm) provided the minimum valve clearance is maintained.
Valve guide bore diameter.	0.2756/ 0.2760	7.009/ 7.000	0.002	
Outside diameter	0.3948/ 0.3946	10.029/ 10.023		
Bore for valve guide in cylinder head	0.3941/ 0.3937	10.011/ 10.000		
Inserting pressure	220 lb.	100 kg		With cylinder head cold.
Valve guide protrusion.	0.165/ 0.157	4.2/4.0		Valve guides without collar only.
Rocker bore diameter.	0.7099/ 0.7096	18.033/ 18.024	0.002	
Rocker shaft diameter	0.7084/ 0.7080	17.994/ 17.983	0.002	After pressing in.
Rocker radius.	0.315	8		No flattening permitted.
Rocker axial play.	0.008/ 0.026	0.20/ 0.65		
Valve seat ring seat angle.	45 deg.			
Crankshaft				
Roughness RA. (μ)	0.3			
Crank pin width.	1.2992/ 1.3017	33.062/ 33.000		Bearing clearance new .0018-.0030 in (0.046-0.076 mm)
Hardness at crank pin. (RC)	50/55			Max. permissible bearing clearance 0.009 in (0.23 mm).
Hardness depth at crank pin.	0.043/ 0.060	1.1/1.5		Out-of-round over total length max. 0.0002 in (0.005 mm)
Diameter of crankpin (new engine)	1.6512/ 1.6508	42.00/ 41.93		Max. permissible out-of-round of crankpin 0.0020 in (0.05 mm). Amount of taper over total length max. 0.00012 in (0.003 mm).

Item	Size (In)	Size (mm)	Max. Perm. Wear (in)	Remarks
Wall thickness of bearing shells (new engine).	0.0787/ 0.0791	2.010/ 1.998		
Diameter of crankpin (undersize).	1.6315/ 1.6311	41.440/ 41.430		Corner radius crankpin 0.1181 in (3 mm).
Wall thickness of bearing shells (oversize).	0.0885/ 0.0890	2.260/ 2.248		
Diameter for ball hub (governor).	1.1428/ 1.1433	29.041/ 29.028		
Diameter for ball shell.	1.1015/ 1.1007	27.980/ 27.959		
Ball shell inside diameter.	1.1035/ 1.1055		0.0007	
Diameter for gearwheel on crankshaft	0.8675/ 0.8680	22.048/ 22.035		
Regrind at crank pin.	0.0197	0.5		
Axial play: a) Cold engine (10-30° C).	0.012/ 0.032	0.3/0.8		
b) At working temperature	0.016/ 0.036	0.4/0.9		
Connecting Rod				
Bore diameter for piston pin bushing.	1.1024/ 1.1029	28.013/ 28.000		
Bore for journal bearing.	1.8108/ 1.8114	46.010/ 45.094		
Bushing, piston pin, external diameter.	1.1043/ 1.1037	28.048/ 28.035		
Bushing, piston pin, internal diameter: Loose Assembled	0.9875/ 0.9869 0.9856/ 0.9850	25.082/ 25.068 25.033/ 25.020	0.006 in 0.15mm	
Bearing cap bolt thread		M8		
Journal Bearing				
Outside diameter.	1.811	46		Bearing play In new condition .0015/.0030in, 0.040/0.076mm
Inside diameter	1.6529/ 1.6538	42.006/ 42.014	1.659 in 42.15mm	
Width.	1.0433/ 1.0354	26.5/26.3		

Item	Size (In)	Size (mm)	Max. Perm. Wear (in)	Remarks
Undersize.	1.6339	415		
Piston				
Piston diameter.	2.8724	72.96		
Oversize.	+0.1968/ +0.0393	+0.5/ +0.1		
Length of piston.	3.2283	82.0		
Cylinder				
Bore diameter. 2 8744	2.8740/	73 00/ 73.01	Up to 0.0006 in 0.15mm	
Roughness (RA).		0.9/1.3		
Oversize	0.0197/ +0.0393	+0 5/ +1.0		

Table 5-4. Piston Ring Data

Groove No.	Designation	Dimension (mm)		Gap (mm)	
				Nom.	Max.
I	R-ring (barrel-machined) if CRB	Standard	73 x 2	0.20	0.8
		Oversize	74 x 2	0.45	0.8
II	M-compr-ring(taper faced)	Standard	73 x 2	0.25	1.5
		Oversize	74 x 2	0.45	1.5
III	G-ring (double beveled oil control ring)	Standard	73 x 4	0.20	1.5
		Oversize	74 x 4	0.45	1.5

5-6. DIESEL ENGINE.

A INTRODUCTION This paragraph contains repair and maintenance instructions for the Direct Support Level on the Diesel Engine

5-6.1. ENGINE FLYWHEEL.

This task covers: A. Inspect B. Replace

Tools:

Shop Set, Automotive Field
Maintenance, Basic
Socket, 61209900

Materials/Parts:

Diesel Fuel Oil NSN 9140-00-286-5294
Equipment Conditions:
Engine Secured and Cooled

A. Inspect.

1. Removing the Flywheel Assembly.

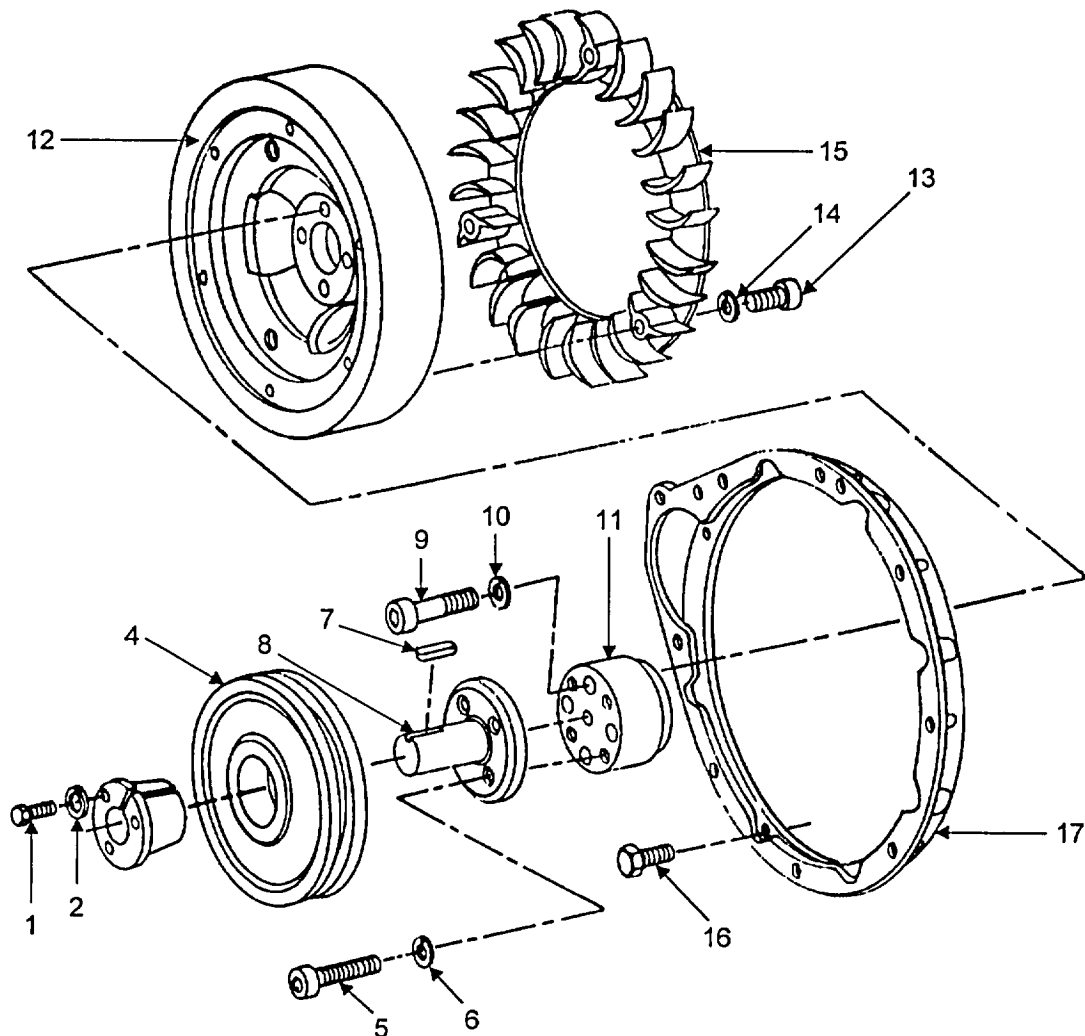

FIGURE 5-1. ENGINE FLYWHEEL/IMPELLER ASSEMBLY

- a. Remove three hex head cap screws (Figure 5-1, Item 1) and lock washers (2) from split taper bushing (3).
- b. Remove bushing (3) and groove pulley (4).
- c. Remove four socket head cap screws (5) and washers (6) from the stub shaft (8).
- d. Remove stub shaft (8). Be sure not to misplace stub shaft key (7).

- e. Remove socket head screws (9) that go through the retainer (11) into the crank shaft.
- f. Slide flywheel (12) and impeller (15) off the crankshaft as a unit
- g. Remove three screws (13) and six lock washers (14).
- h. Separate impeller (15) from flywheel (12).

2. Cleaning and Inspecting the Parts.

WARNING

DEATH OR SERIOUS INJURY COULD OCCUR IF FUEL IS NOT HANDLED CAREFULLY. USE IN A WELL VENTILATED AREA AWAY FROM OPEN FLAME, ARCING EQUIPMENT, IGNITION SOURCES, HEATERS, OR EXCESSIVE HEAT. ENGINE MUST BE SHUT DOWN AND COOL BEFORE REFUELING. ALWAYS STORE FUEL IN PROPER, MARKED CONTAINERS. DO NOT SMOKE.

WARNING

DEATH OR SERIOUS INJURY COULD OCCUR IF COMPRESSED AIR IS DIRECTED AGAINST THE SKIN. DO NOT USE COMPRESSED AIR FOR CLEANING OR DRYING UNLESS THE PRESSURE HAS BEEN REDUCED TO 30 PSI (2.06 BAR) OR LESS. WHEN WORKING WITH COMPRESSED AIR ALWAYS USE CHIP GUARDS, EYE PROTECTION, AND OTHER PERSONAL EQUIPMENT.

- a. Clean flywheel thoroughly with diesel fuel Use wire brush if necessary.
- b. Dry flywheel with low pressure compressed air.
- c. Inspect flywheel for cracks, rust, corrosion or other damage.
- d. Replace damaged or cracked flywheel
- e. Clean impeller thoroughly with diesel fuel. Use a soft-bristle brush to clean impeller.
- f. Dry impeller with low pressure compressed air.
- g. Inspect impeller for cracks, rust, corrosion, or other damage.
- h. Check for damaged, chipped, or broken impeller blades.
- i. If blades are broken, cracked or chipped, replace impeller.
- j. Check keyway of stub shaft for cracks or galling

B. Replacing/Reinstalling the Flywheel Assembly.

- a. Smooth out nicks or burrs on flywheel and impeller. Remove rust or corrosion, then clean with diesel fuel oil.
- b. Dry components, with low pressure compressed air.
- c. Reassemble the components, using replacement parts as necessary.
- d. Reinstall parts in reverse order of removal.

e. Torque cap screws (Figure 5-1, Items 5 and 9) to 51.6 lb.-ft (70 Nm) and cap screws (13) to 22.13 lb.-ft (30 Nm).

5-6 2. FUEL INJECTION PUMP.

This task covers: A. Test B. Remove C. Install D. Adjust

Tools:

- Tool Kit, General Mechanic's Set
- Shop Equipment, Automotive Maintenance and Repair
- Testing Device for Injection Equipment 60462800
- Dial Gauge, 61208700
- Spill Device, 66503001
- Socket Wrench, 30 mm, 66833500
- Special Wrench, 60600000

Materials/Parts:

- Diesel Fuel NSN 9140-00-268-5294
- Lubricating Oil
- Shim Set

Equipment Conditions:

- Fuel Lines and Check Valve Removed

A. Test.

1. Testing the Fuel Injection Pump.

NOTE

Perform this test both before removal of the injection pump from the engine and after re-installation.

WARNING

DEATH OR SERIOUS INJURY COULD OCCUR IF FUEL IS NOT HANDLED CAREFULLY. USE IN A WELL VENTILATED AREA AWAY FROM OPEN FLAME, ARCING EQUIPMENT, IGNITION SOURCES, HEATERS, OR EXCESSIVE HEAT. ENGINE MUST BE TURNED OFF AND COOL BEFORE REFUELING. ALWAYS STORE FUEL IN PROPER, MARKED CONTAINERS. DO NOT SMOKE.

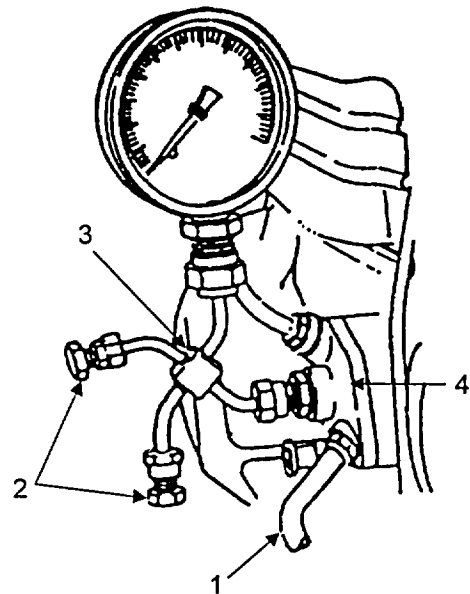

FIGURE 5-2. INJECTION PUMP TEST

- a. Connect fuel hose (Figure 5-2, Item 1) from fuel tank to injection pump (4).
- b. Ensure the extra fuel device button is not pulled out. If the button is extended, push it back in.
- c. Connect testing device 60462800 (3) to injection pump (4). Ensure side connections (2) are tightly capped.
- d. Loosen the pressure gauge connection and crank the engine until trapped air is removed from the system.
- e. Tighten pressure gauge connection.

CAUTION

Do not scratch or mar mating surfaces of pump body or cover. The fuel injection pump may leak or otherwise malfunction after reassembly.

f. Slowly crank the engine by hand. As the engine is cranked, read fuel injection pressure on the gauge. Injection pressure should be 4350 to 5075 psi (300 to 350 bar). Stop cranking engine and observe. If pressure is maintained. If pressure drops below 3625 psi (250 bar) within 10 to 15 seconds, then injection pump is not in working order.

- g. Depressurize fuel injector by loosening side nuts (2).
- h. Remove testing device 60462800 (3).

B. Remove.

1. Removing the Fuel Injection Pump

- a. Move throttle control lever to the STOP position and pull out the extra fuel button

CAUTION

Do not scratch or mar mating surfaces of pump body or cover. The fuel injection pump may leak or otherwise malfunction after reassembly.

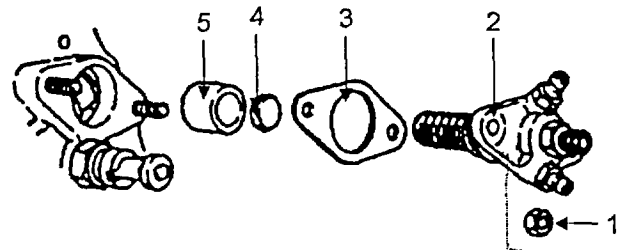

- b. Remove two hex nuts (Figure 5-3, Item 1) and remove injection pump (2).

- c. Remove shim(s) (3), plate (4), and tappet (5)

FIGURE 5-3. FUEL INJECTION PUMP - REMOVAL

WARNING

DEATH OR SERIOUS INJURY COULD OCCUR IF FUEL IS NOT HANDLED CAREFULLY. USE IN A WELL VENTILATED AREA AWAY FROM OPEN FLAME, ARCING EQUIPMENT, IGNITION SOURCES, HEATERS, OR EXCESSIVE HEAT. ENGINE MUST BE SHUT DOWN AND COOL BEFORE REFUELING. ALWAYS STORE FUEL IN PROPER, MARKED CONTAINERS. DO NOT SMOKE.

WARNING

DEATH OR SERIOUS INJURY COULD OCCUR IF COMPRESSED AIR IS DIRECTED AGAINST THE SKIN. DO NOT USE COMPRESSED AIR FOR CLEANING OR DRYING UNLESS THE PRESSURE HAS BEEN REDUCED TO 30 PSI (2.06 BAR) OR LESS. WHEN WORKING WITH COMPRESSED AIR ALWAYS USE CHIP GUARDS, EYE PROTECTION, AND OTHER PERSONAL EQUIPMENT.

C. Install.

1. Installing the Fuel Injection Pump.

a. Install tappet (Figure 5-4, Item 1) into crankcase (2).

b. Turn engine by hand until tappet (1) reaches the lowest point of cam.

c. Position throttle control hand lever so that governor lever slot (3) lies exactly in the center of the tappet bore.

d. Install plate (4) with the flat surface toward injection pump (6). Place appropriate shims from shim set (5) on crankcase studs.

f. Position injection pump (6) so that control sleeve pin is aligned with the slot in the governor lever.

g. Insert injection pump (6) taking care not to move the control sleeve pin out of alignment.

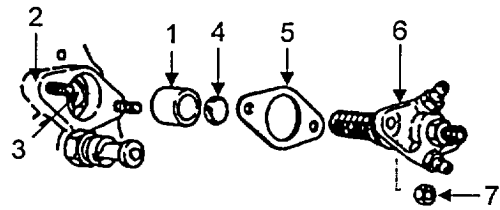

FIGURE 5-4. FUEL INJECTION PUMP-INSTALLATION

NOTE

No resistance should be felt until the pump is within 0.160 inch (4 mm) of the crank-case, then a resistance due to initial load of plunger spring can be felt.

CAUTION

Do not tighten pump if not seated properly. Damage to pump, governor lever, or engine could result if improperly installed.

h. Using hand pressure, insert injection pump (6) fully into crankcase (2) and install two hexagon nuts (7).

i. If the pump does not seat properly, the control sleeve pin of injection pump has not entered the slot (3) in the governor lever and steps f through h should be repeated.

D. Adjust.

CAUTION

When adjusting timing, give special attention to rotation of engine. Timing can be accomplished only when engine is rotated correctly. Correct rotation is counter-clockwise when facing the flywheel.

1. Preliminary Steps. Prepare for adjustments of the injection pump as follows:

a. Remove obstructions to expose engine flywheel.

- b. Connect a gravity feed fuel hose to the injection pump.
- c. Place hand throttle control lever in full throttle position and center the pump control fork in relation to the bore in the crankcase.

NOTE

It may be necessary to loosen the lock nut with 30 mm socket wrench 66833500 and turn the extra fuel button slightly, using special tool 60600000, adjusting wrench for extra fuel device.

- d. Hold the extra fuel device and tighten the lock nut to establish a reference point
- e. Install the injection pump without shim but using two paper gaskets

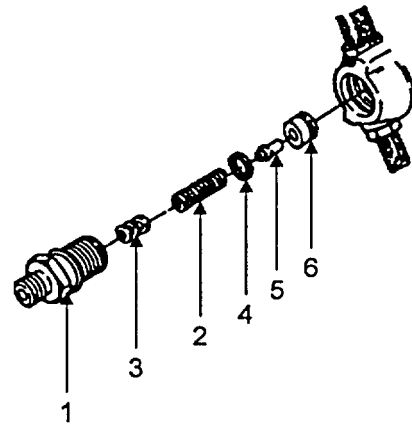

FIGURE 5-5. DELIVERY VALVE HOLDER

- f. Turn the crankshaft so that the cam is at its lowest point
- g. Unscrew delivery valve holder (Figure 5-5, Item 1) and remove spring (2), filling piece with shims (3), copper washer (4), delivery valve (5), and valve body (6).
- h. Insert copper washer (4) and delivery valve body (6) only into spill device 66503001.

i. Thread spill device 66503001 (Figure 5-6, Item 1) into injection pump with spill pipe (2) in the up position, and then secure in place.

j. Install dial gauge 61208700 with adapter pin 1.64 inch (41 mm) long attached, into spill device and pretension approximately 1 mm (one rotation of dial indicator hand).

k. Remove fuel shutoff clamp from fuel hose.

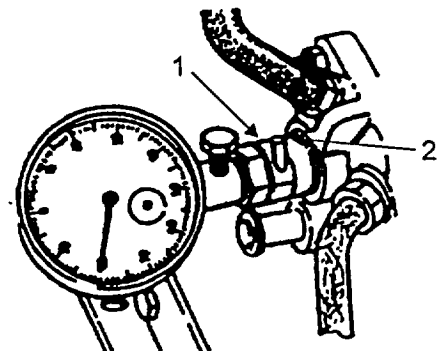

FIGURE 5-6. FUEL PUMP AND SPILL DEVICE

NOTE

Fuel emerging from the spill pipe on spill device 66503001 must be bubble free.

- 2. Adjustment of Delivery End. Delivery end of the fuel injection pump is adjusted as follows:

NOTE

The position of TDC (Figure 5-7, Item 2) and end of delivery (3) is marked on the flywheel (1). The corresponding alignment mark (4) is on the right upper side of the crankcase.

- a. Slowly rotate the flywheel counterclockwise (when facing flywheel) until no fuel emerges from spill pipe on spill device 66503001.
- b. Continue to very slowly rotate flywheel while frequently blotting spill pipe with rag to absorb fuel, until fuel just begins to weep from the spill pipe.

NOTE

The position achieved above is the end of delivery. When the shim set is of the correct thickness, the timing marks (3) on the fly-wheel (1) (11.5 to 12.5 degrees) should align with reference mark (4).

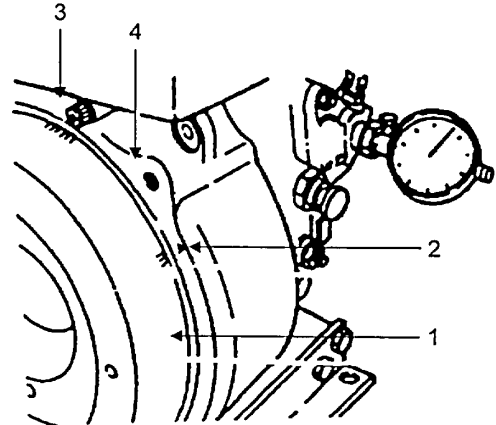

FIGURE 5-7. REFERENCE MARKS

- c. Block fuel hose (from fuel tank) using fuel shutoff clamp.
- d. If timing marks do not align with reference mark (4), rotate the outer face of the dial gauge 61208700 until "0" mark aligns with needle

- e. Slowly rotate the flywheel (1) in either direction to align timing marks of 11.5 to 12.5 degrees with reference mark (4) Gauge reading will indicate amount of re-shimming required

NOTE

The end of delivery is delayed or advanced by adding or removing shims (Figure 5-8, Item 1) to injection pump (2). The general rule for shimming is as follows: More shims = end of delivery later (lower number of degrees). Less shims = end of delivery earlier (higher number of degrees).

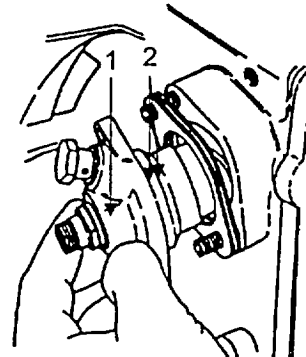

FIGURE 5-8. PLACING SHIMS

- f. Remove fuel shutoff clamp from fuel hose.

- g. After correction of shimming, repeat steps 1 and 2.

3. Adjustment of Delivery Lift. Adjust for delivery lift as follows:

NOTE

Delivery lift controls the quantity of fuel which is injected at full throttle. The delivery lift measurement for a particular engine is stamped on the engine data and serial number plate.

- a. With flywheel timing marks (Figure 5-9, Item 2) (11.5 to 12.5 degrees) aligned with reference mark (3), rotate dial gauge 61208700 face to zero.

b. Slowly rotate flywheel (1) in a clockwise direction when facing flywheel, until dial gauge indicates the delivery lift measurement. See note above.

c. Stop flywheel at position indicated in step 2.

WARNING

DEATH OR SERIOUS INJURY COULD OCCUR IF FUEL IS NOT HANDLED CAREFULLY. USE IN A WELL VENTILATED AREA AWAY FROM OPEN FLAME, ARCING EQUIPMENT, IGNITION SOURCES, HEATERS, OR EXCESSIVE HEAT. ENGINE MUST BE TURNED OFF AND COOL BEFORE REFUELING. ALWAYS STORE FUEL IN PROPER, MARKED CONTAINERS. DO NOT SMOKE.

d. At this point, fuel should emerge again from the spill pipe (Figure 5-10, Item 1) of spill device (2)

NOTE

If fuel does not emerge, turn the extra fuel device. If the results are not obtained, turn the extra fuel device in the opposite direction.

e. Loosen extra fuel button jam nut (Figure 5-11, Item 2) with 30 mm socket wrench, 66833500.

f. Using special wrench 60600000, slightly rotate extra fuel device (1) until fuel starts dripping.

- g. Tighten extra fuel button jam nut (2)
- h. Block fuel hose (from fuel tank) using fuel shutoff clamp.
- i. Remove dial gauge, with spill device attached.
- j. Remove delivery valve body (Figure 5-12, Item 1) and copper washer (2) from spill device.
- k. Install filling piece with three shims (3) in delivery valve holder (4).
- l. Insert spring (5) in delivery valve holder (4).
- m. Insert copper washer (2) in delivery valve holder (4)
- n. Insert delivery valve (6) in valve body (1)
- o. Insert delivery valve (6), and valve body (1) into delivery valve holder (4)

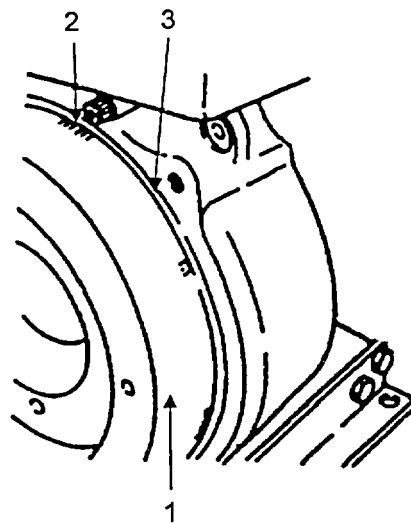

FIGURE 5-9. TIMING MARKS

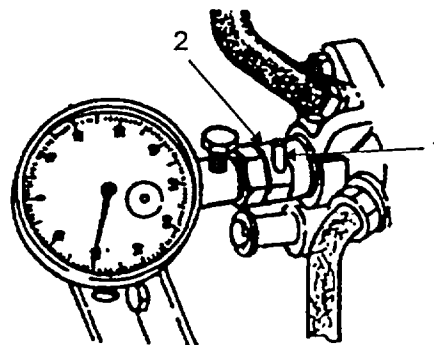

FIGURE 5-10. CHECKING DELIVERY LIFT

NOTE

Verify that grooved end in the valve body enters injection pump opening first.

p. Install new preformed packing (7), and then tighten delivery valve holder assembly into injection pump.

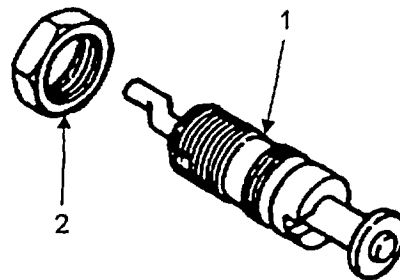

FIGURE 5-11. EXTRA FUEL DEVICE

WARNING

BEFORE STARTING THE ENGINE AND AFTER MAKING REPAIRS OR ADJUSTMENTS ON THE FUEL SYSTEM, A 17 MM OPEN END WRENCH MUST BE AVAILABLE TO ALLOW RAPID REMOVAL OF THE STEEL FUEL LINE AT THE INJECTION PUMP IN CASE OF A RUNAWAY CONDITION. FAILURE TO HEED THIS WARNING COULD RESULT IN INJURY OF PERSONNEL AND EQUIPMENT DAMAGE.

q. Install fuel hoses, and hose clamps in reverse order of removal. Remove fuel shutoff clamp from fuel hose.

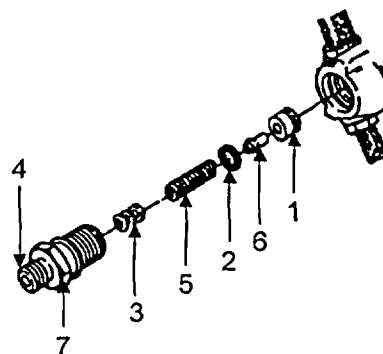

FIGURE 5-12. DELIVERY VALVE REASSEMBLY

5-6 3. HAND CRANK ASSEMBLY GEARS.

This task covers. A. Remove B. Inspect C Install

Tools:

- Shop Equipment, Automotive
- Maintenance and Repair
- Tool Kit, General Mechanic's Set

Materials/Parts:

- Diesel Fuel NSN 9140-00-286-5294
- Grease, MIL-G-10925 NSN 9150-00-190-0705
- Grease, MIL-G-21164 NSN 9150- 00-985-7317
- Gasket,(3) (PIN 03210000)

Equipment Conditions'

- Engine Secured, Removed From Frame
- and Placed on a Work Bench

A. Remove.

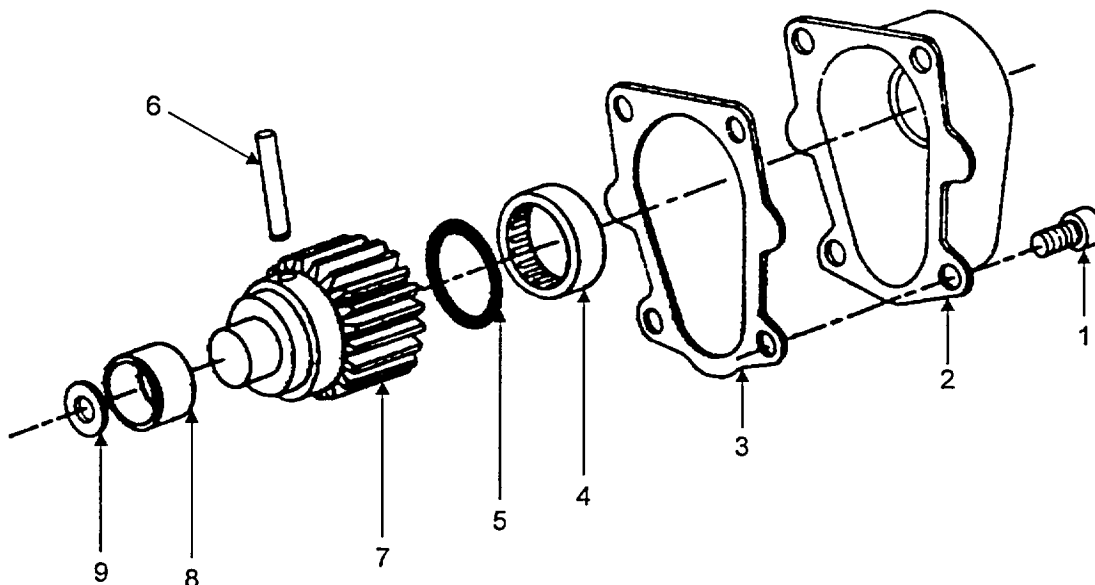

FIGURE 5-13. HAND CRANK ASSEMBLY GEARS

1. Removing the Gears for Inspection.
 - a. Remove four socket head cap screws (Figure 5-13, Item 1) and remove housing (2).
 - b. Remove and discard gasket (3)
 - c. Remove needle bearing (4), oil seal (5), gear wheel (7) and locking pin (6) as an assembly.
 - d. Remove needle bearing (4), oil seal (5), and locking pin (6) from gear wheel (7).
 - e. Remove bushing (8) and disk (9).

B. Inspect

1. Cleaning and Inspecting the Parts.

WARNING

DEATH OR SERIOUS INJURY COULD OCCUR IF FUEL IS NOT HANDLED CAREFULLY. USE IN A WELL VENTILATED AREA AWAY FROM OPEN FLAME, ARCING EQUIPMENT, IGNITION SOURCES, HEATERS, OR EXCESSIVE HEAT. ENGINE MUST BE TURNED OFF AND COOL BEFORE REFUELING. ALWAYS STORE FUEL IN PROPER, MARKED CONTAINERS. DO NOT SMOKE.

WARNING

DEATH OR SERIOUS INJURY COULD OCCUR IF COMPRESSED AIR IS DIRECTED AGAINST THE SKIN. DO NOT USE COMPRESSED AIR FOR CLEANING OR DRYING UNLESS THE PRESSURE HAS BEEN REDUCED TO 30 PSI (2.06 BAR) OR LESS. WHEN WORKING WITH COMPRESSED AIR ALWAYS USE CHIP GUARDS, EYE PROTECTION, AND OTHER PERSONAL EQUIPMENT.

- a. Clean housing (2), gear wheel (7), and pinion (12) with diesel fuel and dry with compressed air.
- b. Inspect all components for damage or excessive wear. Replace any damaged or worn components.

C. Install.

1. Installing the Gears

CAUTION

If either the gear wheel or pinion needs to be replaced, replace both. Timing marks on the small pinion must be aligned with the keyway on the tapered shaft. The timing marks on the gear wheel must be aligned with the mark on the small pinion. Failure to heed this caution can damage equipment.

- a. Slide pinion (Figure 5-13, Item 12) onto camshaft. Install lock washer (11) and hexagon nut (10) and tighten securely.
- b. Install disc (9) into timing cover housing with graphite side of disc (9) facing outward.
- c. Lubricate dry bushing (8) in timing cover housing with MIL-G-10925 grease.
- d. Install gear wheel (7) into dry bushing (8) and secure gear wheel (7) with locking pin (6)
- e. Install oil seal (5) and needle bearing (4) onto gear wheel (7).
- f. Fill housing (2) with MIL-GL-21164 grease. Mount new gasket (3) and housing (2) onto timing cover with four socket head cap screws (1)

5-6.4. CYLINDER HEAD AND VALVE ASSEMBLY

This task covers' A Remove B. Clean C. Inspect D. Install E. Adjust F. Repair

Tools:

- Shop Set, Automotive Field
- Maintenance, Basic
- Dial Gauge, 61208700
- Retainer Bracket, 61275200

Materials/Parts:

- Diesel Fuel NSN 9140-00-286-5294
- Valve Cover Gaskets (PIN 03208902)
- Preformed Packing PIN 50288000)
- Shim (5) (P/N 03209101)
- Valve Head Gaskets

Equipment Conditions:

- Oil Bath Air Cleaner Removed
- Muffler Removed
- Injector Removed From Cylinder Head

A. Remove.

1. Removing the Cowling.

- a. Remove screw (Figure 5-14, Item 1) and hex nut (2) from cowling (3)
- b. Remove the socket head cap screws (4) and lock washers (5) holding the cowling to the engine block.
- c. Remove cowling (3) from engine.

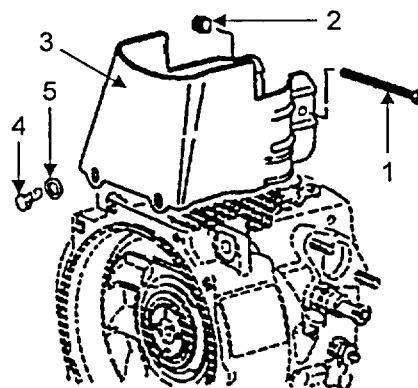

FIGURE 5-14. REMOVE COWLING

2. Removing the Valve Cover.

- a. Loosen cap screw (Figure 5-15, Item 1), washers (2) and pipe clip (3).
- b. Remove two nuts (4) and two lock washers (5).
- c. Lift valve cover (6) off cylinder head.
- d. Remove and discard gasket (7)

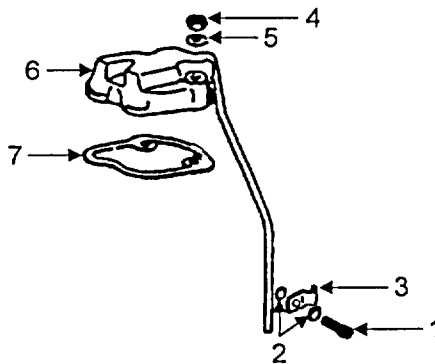

FIGURE 5-15. REMOVE VALVE COVER

3. Removing the Rocker Assembly.

- a. Remove four nuts (Figure 5-16, Item 1) from four studs (2).
- b. Remove rocker shaft (3) with rockers, lifting eye, and two air shields.
- c. Remove clamp (4).

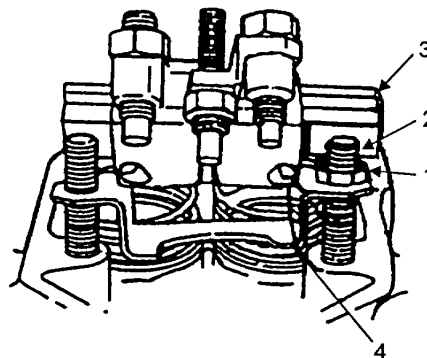

FIGURE 5-16. REMOVE ROCKER ARM

4. Removing the Cylinder Head and Pushrods.

- a. Remove cylinder head (Figure 5-17, Item 1) and gasket (2). Discard gasket.
- b. Remove pushrod (Figure 5-18, Item 1) and complete pushrod (2) from protection tubes (3).
- c. Remove protection tubes (3), preformed packings (4), shims (5) and pressure springs (6). Discard packing and springs.

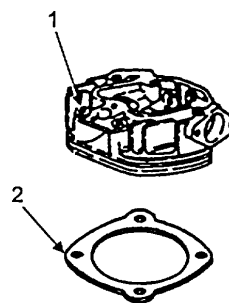

FIGURE 5-17. CYLINDER HEAD

NOTE

Complete pushrod (2) is located on the injection side of the engine. 5 Disassembling the Components. Disassemble components for inspection as follows:

CAUTION

Do not scratch the cylinder head sealing face. Scratches will cause poor sealing of cylinder head and cylinder surfaces.

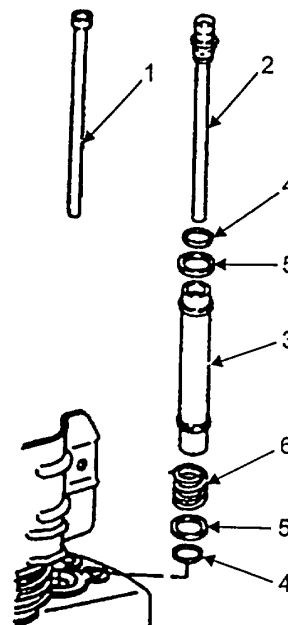

FIGURE 5-18. PUSHROD ASSEMBLY

- a. Press down cup (Figure 5-19, Item 1) and remove collets (2).
- b. Remove valve spring (3), washer (4) and cap (5).
- c. Remove valve (6) from cylinder head (7).
- d. Remove nut (Figure 5-20, Item 1) from threaded pin (2) Unscrew and remove pin (2).
- e. Using needlenose pliers, remove pin (3) with 10 spring plates (4) and preformed packing (5) attached.
- f. Remove preformed packing (5) Discard packing.
- g. Knock out pin (6) and remove decompression shaft (7) and pinion (8) from cylinder head (9).

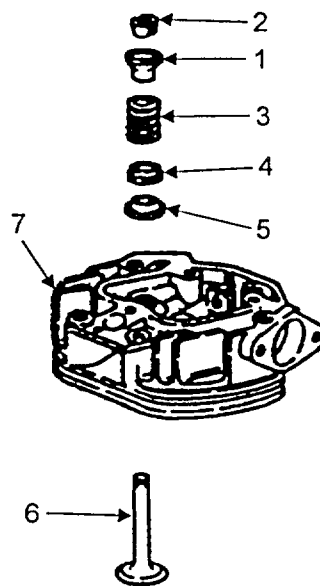

FIGURE 5-19. DISASSEMBLE VALVES

- B Clean.
- 1. Cleaning the Parts for Inspection.

WARNING

DEATH OR SERIOUS INJURY COULD OCCUR IF FUEL IS NOT HANDLED CAREFULLY. USE IN A WELL VENTILATED AREA AWAY FROM OPEN FLAME, ARCING EQUIPMENT, IGNITION SOURCES, HEATERS, OR EXCESSIVE HEAT. ENGINE MUST BE SHUT DOWN AND COOL BEFORE REFUELING. ALWAYS STORE FUEL IN PROPER, MARKED CONTAINERS. DO NOT SMOKE.

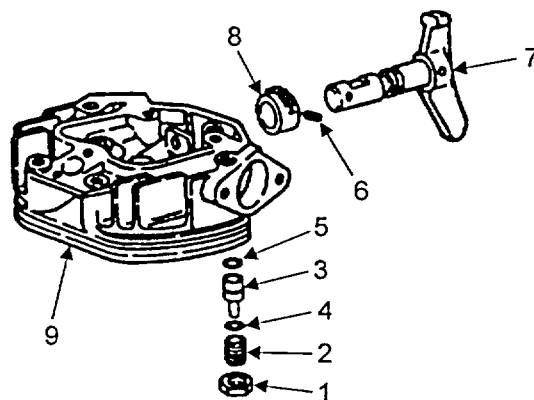

FIGURE 5-20. DISASSEMBLE DECOMPRESSION MECHANISM

WARNING

DEATH OR SERIOUS INJURY COULD OCCUR IF COMPRESSED AIR IS DIRECTED AGAINST THE SKIN. DO NOT USE COMPRESSED AIR FOR CLEANING OR DRYING UNLESS THE PRESSURE HAS BEEN REDUCED TO 30 PSI (2.06 BAR) OR LESS. WHEN WORKING WITH COMPRESSED AIR ALWAYS USE CHIP GUARDS, EYE PROTECTION, AND OTHER PERSONAL EQUIPMENT.

a. Clean all parts in a shop parts washer if available, or with a clean cloth dampened with diesel fuel oil. Use wire brush where necessary. Dry with low pressure compressed air.

C Inspect.

1. Inspecting the Parts.

a. Inspect all parts for cracks, rust, corrosion, and excessive heat damage.

b. Inspect for accumulated carbon around injector seat in cylinder head.

c. Measure rocker shaft (Figure 5-21, Item 1) diameter. If rocker shaft diameter is smaller than 0.7074 inch (17.974 mm), it must be replaced.

d. Measure rocker bore bushing (2) inside diameter. If rocker bushing bore is greater than 0.7084 inch (17.994 mm) replace bushing (2).

e. Measure rocker (3) radius. The radius must be 0.315 inch (8 mm). No flattening or brinnelling is permitted on the rocker radius. If there is evidence of flattening, the rocker must be replaced.

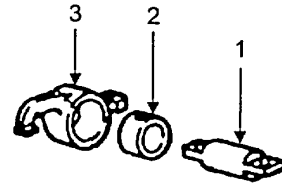

FIGURE 5-21. ROCKER ASSEMBLY

NOTE

When replacing the rocker (3) you must also replace the bushing (2). They are replaced as a set. The bushing (2), however, can be replaced separately.

2. Inspecting the Valve Seats. Check valves, valve seats, and valve guides as follows:

a. Check that the inside diameter of each valve guide does not exceed 0.278 inch (7.059 mm).

b. Check that the valve seat angle does not exceed 45 degrees.

c. Clean valves with diesel fuel and wire brush and dry with low pressure compressed air.

d. Inspect valves for warping, burning, or other damage.

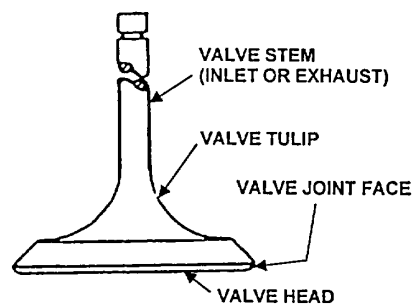

FIGURE 5-22. VALVE ELEMENTS

e. Inspect valve tulips, faces, and heads for pitting, ridges, or cracks

f. Check that each valve stem diameter is not less than 0.2736 in (6.95 mm).

g. Check that each valve head diameter is not less than 1.193 inch (30.3 mm).

h. Replace the cylinder head if any of the following conditions exist: if the cylinder contact surface is roughened, warped, and cannot be repaired; the valve seats are so worn that recutting is no longer possible, if contact surface for cylinder head cover is rough or damaged; or if there are cracks between the valve seats.

D. Install.

1. Installing the Inspected Components.

a. Install pinion (Figure 5-23, Item 8) in cylinder head (9). Gear teeth go toward the inside and no-teeth area of the pinion at the bottom.

b. Insert decompression shaft (7) through cylinder head (9) and into pinion (8).

c. Align holes in pinion (8) and decompression shaft (7).
d. Install roll pin (6).

e. Install new preformed packing (5) on pin (3).

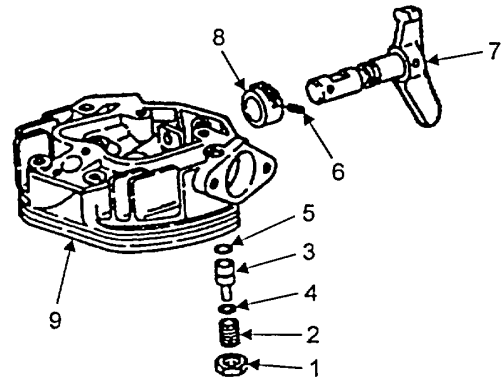

FIGURE 5-23. DECOMPRESSION MECHANISM

f. Install 10 spring plates (4) on pin (3). The spring plates must be installed in five sets with concave sides together to create spring action.

g. Install pin (3) with assembled preformed packing (5) and spring plates (4) into cylinder head (9).

h. Rotate decompression shaft (7) to horizontal position.

i. Install threaded pin (2) and tighten until snug. Shaft must be free to turn but not move with vibration.

j. Secure lock nut (1).

CAUTION

Do not scratch the cylinder head sealing surface. Scratches will cause poor sealing of cylinder head and cylinder surfaces.

k. Insert valve (Figure 5-24, Item 6) into cylinder head (7).

l. Install cap (5), washer (4), valve spring (3) and cup (1).

m. Press down cup (1) and install collets (2).

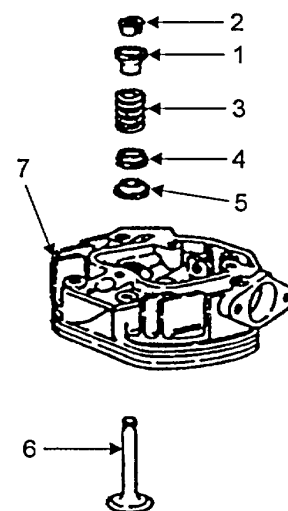

FIGURE 5-24. REASSEMBLE VALVES

2. Installing the Pushrod Assemblies.

a. Install new preformed packing (Figure 5-25, Item 4), shims (5), and new pressure springs (6), on protection tubes (3).

b. Install protection tubes (3).

c. Install complete pushrod (2) closest to injection pump side of engine.

d. Install pushrod (1).

3. Installing the Cylinder Head.

a. Install two hollow dowel pins (Figure 5-26, Item 3) in bottom of cylinder head.

b. Install NEW gasket (2) on bottom of cylinder head (1).

c. Place cylinder head over studs and onto cylinder.

d. Install rocker shaft (Figure 5-27, Item 3) with rockers, two air shields, and lifting eye. Install clamp (4).

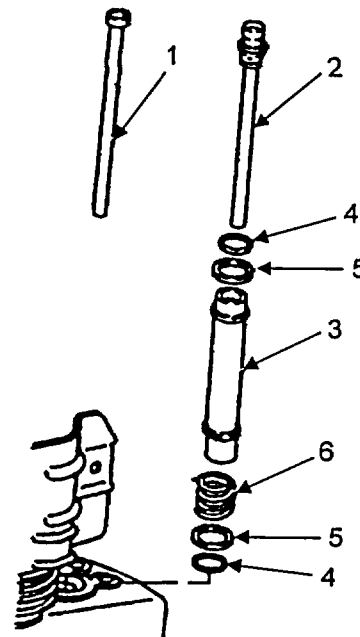

FIGURE 5-25. ASSEMBLE PUSHRODS

e. Install four nuts (1) on the four studs (2). Tighten nuts equally and crosswise to a torque of 26 lb -ft (35 Nm).

4. Completion of Reassembly.

a. Install new gasket (Figure 5-28, Item 6) on cylinder head.

b. Install cylinder head cover (5) on gasket (6).

c. Install two spring washers (4) and nuts (3). Tighten securely.

d. Install pipe clip (2), washers (7), and screw (1).

e. Install cowling (Figure 5-29, Item 3) on engine.

f. Install screw (1) and hex nut (2).

g. Install screws (4) and washers (5).

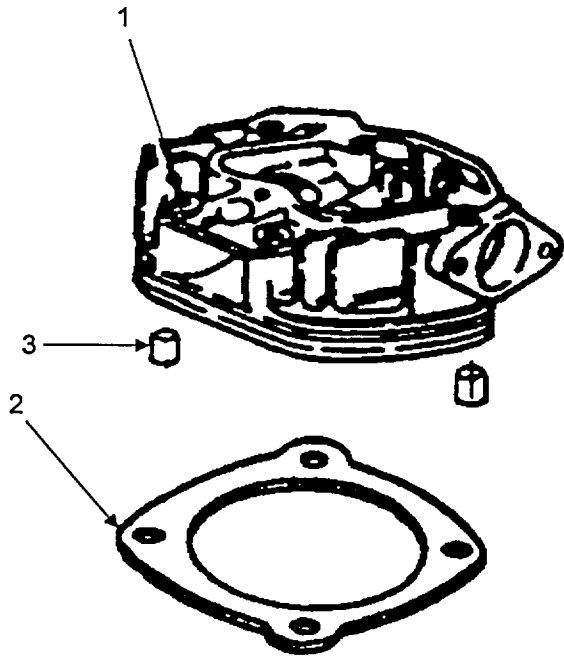

FIGURE 5-26. INSTALL CYLINDER HEAD

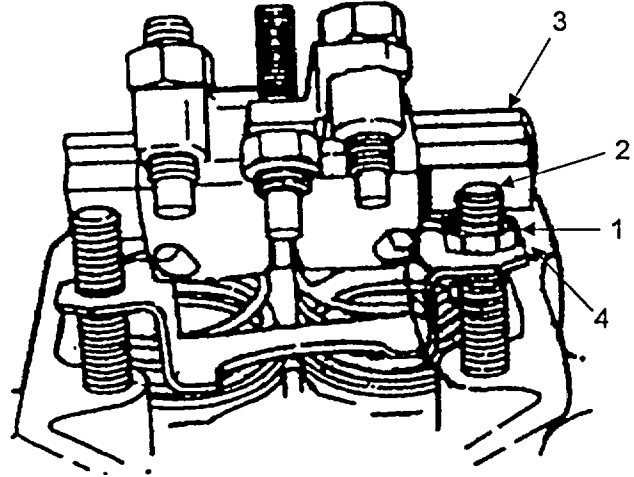

FIGURE 5-27. VALVE HEAD ASSEMBLY

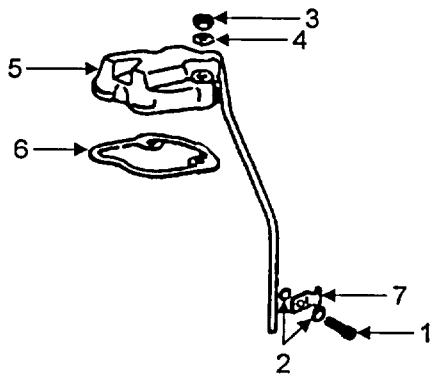

FIGURE 5-28. VALVE COVER

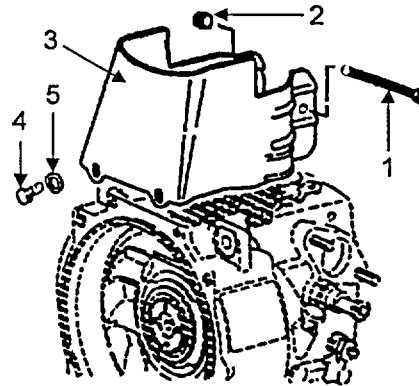

FIGURE 5-29. COWLING

E. Adjust.**CAUTION**

Too small a clearance will damage piston, cylinder head, and valves. Too large a clearance will result in difficult starting.

1. Adjusting the Cylinder Head (Bumping) Clearance.
 - a. Crank engine to dead center position.
 - b. Ensure cylinder head surface is free of dirt, carbon, or sealing material residue and place cylinder head gasket onto cylinder head.
 - c. Use a dial indicator to establish true top dead center of the piston.
 - d. Place a straight edge across the top of the cylinder and measure the distance between the top of the cylinder gasket and the top of the piston with a feeler gauge.
 - e. Ensure that the bumping clearance is between 0.0216/0.0255 inch (0.549/0.648 mm).

NOTE

Gaskets come in various thickness. If you have a choice between two gaskets, it is best to use the thickest one. Use only one gasket with the required thickness.

2. Adjusting the Pushrods.

a. Adjust complete pushrod (Figure 5-30, Item 1) so dimension "A", measured from bottom of pushrod to the top of the collar, equals 5.8189/5.8268 inch (147.8/148.0 mm). This adjustment is required for proper engagement of complete pushrod with pinion on decompression shaft.

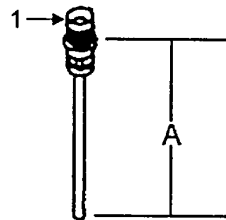

FIGURE 5-30. PUSHROD

3. Adjusting the Tappet Clearance.

a. Put decompression lever (1) in START position. (Figure 4-3).

b. Turn engine clockwise when facing throttle control lever until compression resistance can be felt.

c. Check clearance between rocker and valve stem with a feeler gauge. Tappet clearance cold should be 0.004 Inch (0.10 mm). To correct clearance, loosen nut (2).

d. Adjust screw (Figure 5-31, Item 3) with a screwdriver until feeler gauge can be pulled between rocker and valve stem with very slight resistance after nut (2) has been tightened

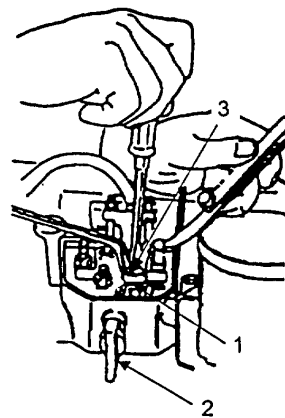

FIGURE 5-31. TAPPET ADJUSTMENT

4. Adjusting the Decompression Screw.

NOTE

Adjustment of the decompression screw (Figure 5-32, Item 3) is required if the engine does not decompress when the decompression lever is in position.

a. Turn the engine in the same direction as for adjusting tappet clearance.

b. Put decompression lever in FREEWHEEL position (Figure 4-3).

c. Using box wrench loosen nut (Figure 5-32, Item 2) and turn adjustment screw (1) clockwise until rocker touches valve stem.

d. Turn adjustment screw (1) another half turn and secure by tightening nut (2).

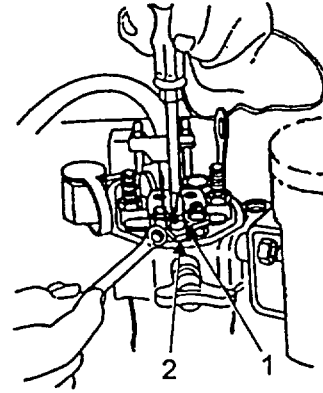

FIGURE 5-32. DECOMPRESSION ADJUSTMENT

5. Adjusting the Pushrod Clearance(s)

NOTE

Check clearance of complete pushrod (Figure 5-33, Item 1) and pinion (2).

a. Use feeler gauge to check that clearance (3) between socket of complete pushrod (1) and pinion (2) is 0.039 inch (1.0 mm).

b. Check that clearance (4) is 0.039 Inch (1.0 mm).

c. Clearances can be adjusted by adjustment complete pushrod (1) for clearance (3) and adjusting rocker shaft for clearance (4).

NOTE

During engine operation. Decompression shaft must not move.

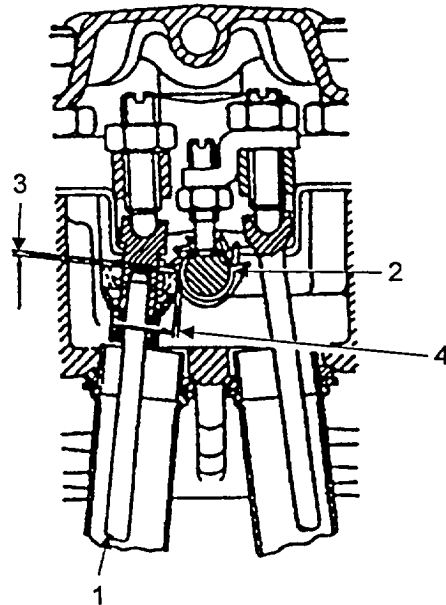

FIGURE 5-33. PUSHROD ADJUSTMENT

F. Repair.

1. Permitted Repairs.

a. If the inside diameter of the cylinder head guide (Figure 5-34, Item 1) exceeds 0.2780 Inch (7.059 mm), replace the guide. Press out the valve guide.

b. From cylinder head bottom, push valve guide (1) out of the cylinder head (2). Insert new valve guide (1) into cylinder head (2). Install new valve guide by pressing in. Minimum Inserting force is 220 lb. (100 kg)

c. Ream the inside diameter of the valve guide to 0.2756/0.2759 in (7.0000/7.009 mm) using hand reamer.

d. Repair defective cylinder head valve seats by recutting with a 45 degree valve seat cutter. Recut valve seats until valve seat is absolutely clean.

e. The contact surface of the cylinder head can be repaired by machining. Remove up to a maximum of 0.0196 inch (0.5 mm) of metal provided the minimum.

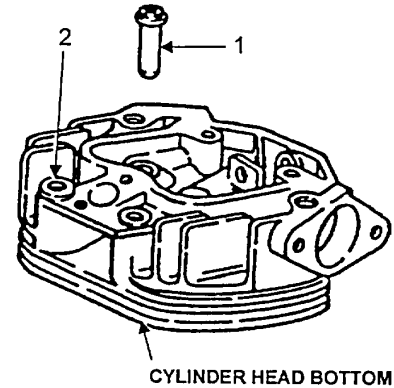

FIGURE 5-34. VALVE GUIDE

f. valve clearance is maintained (Figure 5-35).

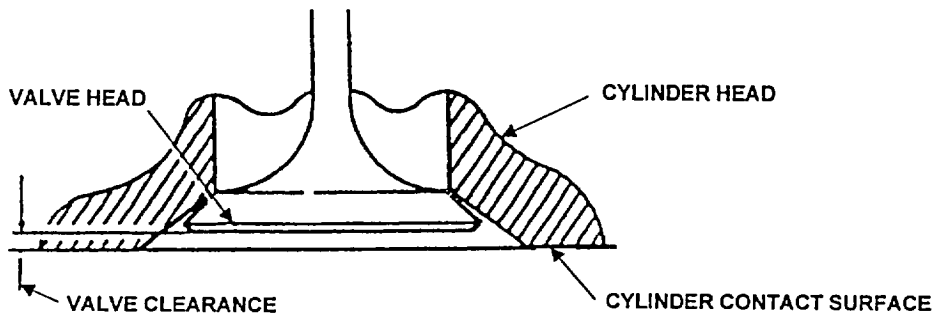

FIGURE 5-35. VALVE CONTACT POINTS

- f. Replace any valves that show head warping, burning or other damage.
- g. Replace valves that have seriously scratched or scuffed stems, or pitted, ridged, or cracked tulips, faces, or heads.
- h. Replace valves that have a valve head diameter of less than 1.193 inch (30.3 mm).
- i. Buff out light scratches or scuff marks with 600 grit tapping and grinding compound.
- j. If the cylinder head valve seats were recut, lap the valves by using 600 grit lapping and grinding compound. After lapping, check valve clearance.

CAUTION

The valve clearance must not be less than 0.018 inch (0.45 mm), otherwise the valve head may touch the piston.

k. The valve clearance shall be a maximum of 0.0275 inch (0.70 mm).

l. After reconditioning or replacing valves, valve seats, or other related work, check proper fit of valves by pouring fuel into the intake and exhaust ports. Observe for leakage at valve seats. A valve fits properly if no fuel leaks through.

5-6.5. ENGINE CYLINDER

This task covers: A. Inspect B. Replace

Tools:

Shop Set, Automotive Field
Maintenance, Basic
Dial Gauge, 61208700

Materials/Parts:

Lubricating Oil
Silicone RTV Sealant NSN 8040-00-225-4548
Solvent, Dry-cleaning) NSN 6850- 00-281-7985

Equipment Conditions:

Fuel Lines Removed
Muffler Removed
Air Cleaner Removed)
Injector Removed From Cylinder Head
Cylinder Head Removed

A. Inspect.

1. Removing the Cylinder for Inspection.

CAUTION

When removing cylinder, make sure piston or connecting rod does not knock against crankcase. This could result in serious damage to piston or connecting rod.

- a. Matchmark cylinder (Figure 5-36, Item 1) and crankcase (2) with marking color to ensure proper installation during assembly.
- b. Lift cylinder (1) from crankcase (2).

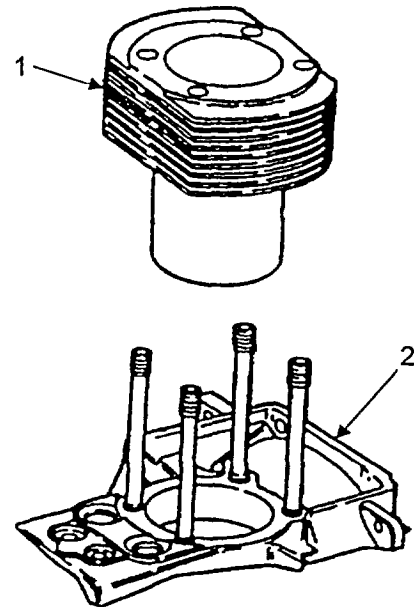

FIGURE 5-36. CYLINDER

WARNING

DRY CLEANING SOLVENT P-D-680 (SAFETY OR STODDARD'S SOLVENT) IS POTENTIALLY DANGEROUS. AVOID REPEATED AND PROLONGED BREATHING OF VAPORS AND SKIN CONTACT WITH LIQUID. DO NOT USE NEAR OPEN FLAME, ARCING EQUIPMENT, OR OTHER IGNITION SOURCES. ALWAYS WEAR EYE PROTECTION AND PROTECTIVE CLOTHING. THE FLASH POINT OF P-D-680 IS 100 TO 138 DEGREES F (38 TO 59 DEGREES C).

WARNING

DEATH OR SERIOUS INJURY COULD OCCUR IF COMPRESSED AIR IS DIRECTED AGAINST THE SKIN. DO NOT USE COMPRESSED AIR FOR CLEANING OR DRYING UNLESS THE PRESSURE HAS BEEN REDUCED TO 30 PSI (2.06 BAR) OR LESS. WHEN WORKING WITH COMPRESSED AIR ALWAYS USE CHIP GUARDS, EYE PROTECTION, AND OTHER PERSONAL EQUIPMENT.

c. Clean cylinder seat in crankcase (Figure 5-36, Item 2) with dry cleaning solvent and dry with low pressure compressed air. Check that cylinder seat is smooth and flat.

d. Clean cylinder thoroughly with dry cleaning solvent Dry with low pressure compressed air. Inspect for warpage, roundness, damage, rust or corrosion. If any of these conditions are found, replace with new cylinder and piston.

NOTE

For piston replacement instructions, refer to paragraph 5-6.6.

e. Inspect cylinder for cracks.

f. Inspect for scoring, glazing, or ridge on the upper portion of inner surface g Inspect for metal particles (fretting) on outer surface.

h. Measure cylinder bore at (Figure 5-37), levels 1 to 4 of engine centerline axis "A" and crossline axis "B". A normal or new bore diameter should be 2.8740 to 2.8744 inches (73.00 to 73.01 mm) If wear limits for a normal bore cylinder have been reached. or exceeded, replace cylinder and piston. If measurements on axis "A" and "B" are different, cylinder is out of round or has high spots. Replace cylinder and piston Refer to Table 5-3

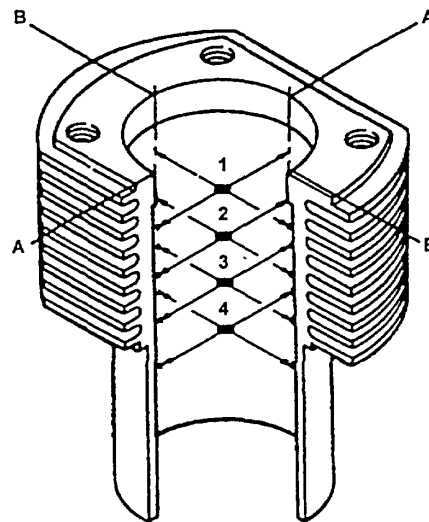

FIGURE 5-37. CYLINDER MEASUREMENT POINTS

i. Check that top and bottom faces of cylinder are smooth and flat If damaged, replace cylinder and piston.

B. Replacing/Reinstalling the Cylinder.

CAUTION

If a new cylinder is installed, use a new piston and rings also. If working on more than one unit at the same time, ensure that if the cylinder is reinstalled, the original piston is used with it in the same orientation as when removed. Always use a piston and cylinder as a matched pair.

WARNING

DEATH OR SERIOUS INJURY COULD OCCUR IF FUEL IS NOT HANDLED CAREFULLY. USE IN A

WELL VENTILATED AREA AWAY FROM OPEN FLAME, ARCING EQUIPMENT, IGNITION SOURCES, HEATERS, OR EXCESSIVE HEAT. ENGINE MUST BE SHUT DOWN AND COOL BEFORE REFUELING. ALWAYS STORE FUEL IN PROPER, MARKED CONTAINERS. DO NOT SMOKE.

WARNING

DEATH OR SERIOUS INJURY COULD OCCUR IF COMPRESSED AIR IS DIRECTED AGAINST THE SKIN. DO NOT USE COMPRESSED AIR FOR CLEANING OR DRYING UNLESS THE PRESSURE HAS BEEN REDUCED TO 30 PSI (2.06 BAR) OR LESS. WHEN WORKING WITH COMPRESSED AIR ALWAYS USE CHIP GUARDS, EYE PROTECTION, AND OTHER PERSONAL EQUIPMENT.

- a. Remove slight ridges, score marks, and glaze with hone brush, equipped with 20-grit stones. Work hone up and down rapidly the full length of the cylinder bore several times in a crisscross pattern. Criss-cross pattern produces hone marks on a 45-degree axis, which aid piston movement and helps prevent formation of ridges.
- b. Clean cylinder with dry cleaning solvent and dry with low pressure compressed air. Remove any burrs.
- c. Recheck cylinder bore and out of round on repaired cylinder as described above. Replace if out of tolerance. Refer to Table 5-3.
- d. Apply a bead of silicone sealant at the base of the finned section of the cylinder to seal the joint between the cylinder and the crankcase.
- e. Install piston in accordance with paragraph 5-6.6. Apply engine lubricating oil to piston rings.
- f. Ensure piston ring gaps are out of alignment by 120 degrees.

CAUTION

When installing cylinder, make sure piston or connecting rod does not knock against crankcase. This could result in serious damage to the piston or connecting rod. Use care when installing cylinder to prevent damage to piston rings.

- g. Compress piston rings with piston ring clamp (Figure 5-38, Item 2).
- h. Apply lubricating oil to inside of cylinder and slowly mount cylinder on studs (4). Remove piston ring clamp (2).

NOTE

The cylinder is designed with an internal bevel at the bottom to assist in insertion of the piston rings. If installing the piston without use of the piston ring clamp, ensure that the 120 degree spacing of ring gaps is maintained.

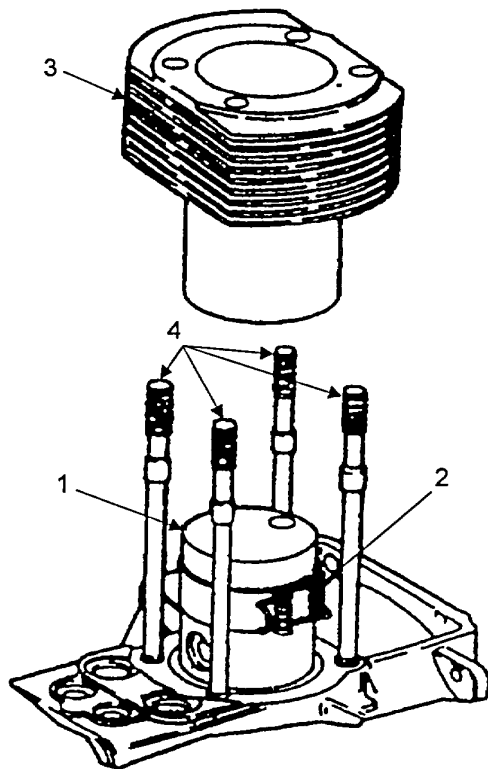

FIGURE 5-38. MOUNTING CYLINDER

5-6.6. ENGINE PISTON.

This task covers- A. Inspect B. Repair C. Replace

Tools:

Shop Set, Automotive Field
Maintenance, Basic

Materials/Parts:

Solvent, Dry Cleaning NSN 6850-00-281-1985
Lubricating Oil

Equipment Conditions:

Cylinder Removed From Engine

- A. Inspect
1. Removing the Piston for Inspection.

CAUTION

When removing cylinder, make sure piston or connecting rod does not knock against crank-case. This could result in serious damage to piston or connecting rod.

- a. Remove retaining ring (Figure 5-39, Item 1).
- b. Press out piston pin (2) far enough to remove piston pin (2) and piston (3) from connecting rod (4).

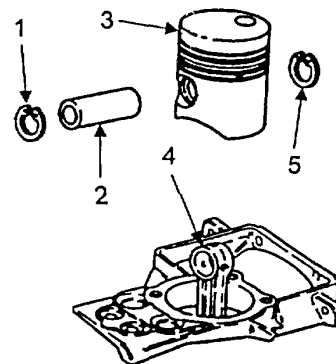

FIGURE 5-39. PISTON

NOTE

The piston pin can be moved by hand if the engine parts are warm. If the engine has already cooled down, heat the piston to 122° F (50° C). If this is not possible, the piston pin can be knocked out. A suitable object must be held against the opposite side of the piston to avoid bending the connecting rod.

- c. Remove piston (Figure 5-39, Item 3) and piston pin (2).
- d. Remove retaining ring (5).

CAUTION

Piston rings may be broken if rings are opened more than necessary when removing or installing them. Do not strain rings.

- e. Remove piston ring set (Figure 5-40, Item 1) from piston (2).

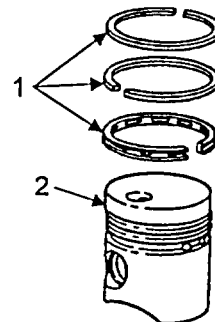

FIGURE 5-40. PISTON RINGS

2. Cleaning the Parts for Inspection

WARNING

DRY CLEANING SOLVENT P-D-680 (SAFETY OR STODDARD'S SOLVENT) IS POTENTIALLY DANGEROUS. AVOID REPEATED AND PROLONGED BREATHING OF VAPORS AND SKIN CONTACT WITH LIQUID. DO NOT USE NEAR OPEN FLAME, ARCING EQUIPMENT, OR OTHER IGNITION SOURCES. ALWAYS WEAR EYE PROTECTION AND PROTECTIVE CLOTHING. THE FLASH POINT OF P-D-680 IS 100 TO 138 DEGREES F (38 TO 59 DEGREES C).

WARNING

DEATH OR SERIOUS INJURY COULD OCCUR IF COMPRESSED AIR IS DIRECTED AGAINST THE SKIN. DO NOT USE COMPRESSED AIR FOR CLEANING OR DRYING UNLESS THE PRESSURE HAS BEEN REDUCED TO 30 PSI (2.06 BAR) OR LESS. WHEN WORKING WITH COMPRESSED AIR ALWAYS USE CHIP GUARDS, EYE PROTECTION, AND OTHER PERSONAL EQUIPMENT.

- a. Clean piston (3) and wrist pin (Figure 5-39, Item 2) with dry cleaning solvent and dry with low pressure compressed air.
- b. Remove carbon from piston ring lands and grooves.
- c. Clean inside surface of piston and piston skirt.
- d. Clean piston pin bore.

3. Checking all the Parts

NOTE

Visually inspect all piston components. Take measurements as indicated.

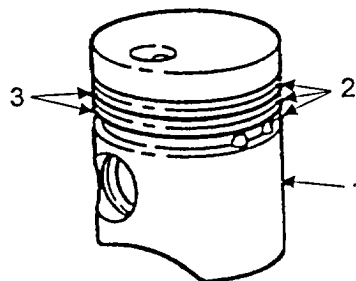

FIGURE 5-41. PISTON GROOVES

- a. Inspect piston, skirt, and piston grooves for excessive wear and damage Replace damaged piston.

NOTE

Excessively worn piston, rings or cylinder may be an indication of abnormal maintenance procedures or operating conditions. Check for and correct any abnormalities.

- b. Examine piston (Figure 5-41, Item 1) for scoring, fretting, pitting, cracks (especially on the interior surfaces), damaged ring grooves, or for indications of overheating Repair slight scoring according to repair procedures. Replace damaged piston.
- c. If piston is badly worn, check cylinder for excessive out-of-round, high spots, or other damage In accordance with paragraph 5-6.5.
- d. Measure piston diameter (Figure 5-42, Item 1) along axis "A" and "B". A normal or new piston diameter should be 2 8724 inches (72 96 mm) If piston is out-of-round, replace piston

e. Measure piston compression ring groove width (Figure 543, Item 1). Measurement should be 0.0828 to 0.0843 inch (2.100 to 2.143 mm). If measurement is greater than 0.843 in (2.143 mm), replace piston.

f. Measure piston ring groove (2) width. Measurement should be 0.0811 to 0.0908 inch (2.060 to 2.310 mm). If measurement is greater than 0.0908 in (2.310 mm), replace piston.

g. Measure oil control ring groove (3) width. Measurement should be 0.1582 to 0.1599 inch (4.020 to 4.060 mm). If measurement is greater than 0.1599 in (4.060 mm), replace piston.

WARNING

DRY CLEANING SOLVENT P-D-680 (SAFETY OR STODDARD'S SOLVENT) IS POTENTIALLY DANGEROUS. AVOID REPEATED AND PROLONGED BREATHING OF VAPORS AND SKIN CONTACT WITH LIQUID. DO NOT USE NEAR OPEN FLAME, ARCING EQUIPMENT, OR OTHER IGNITION SOURCES. ALWAYS WEAR EYE PROTECTION AND PROTECTIVE CLOTHING. THE FLASH POINT OF P-D-680 IS 100 TO 138 DEGREES F (38 TO 59 DEGREES C).

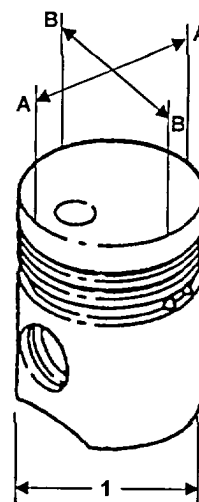

FIGURE 5-42. MEASURE PISTON

WARNING

DEATH OR SERIOUS INJURY COULD OCCUR IF COMPRESSED AIR IS DIRECTED AGAINST THE SKIN. DO NOT USE COMPRESSED AIR FOR CLEANING OR DRYING UNLESS THE PRESSURE HAS BEEN REDUCED TO 30 PSI (2.06 BAR) OR LESS. WHEN WORKING WITH COMPRESSED AIR ALWAYS USE CHIP GUARDS, EYE PROTECTION, AND OTHER PERSONAL EQUIPMENT.

h. If any groove width measurements are smaller than the minimum values given above, piston ring grooves may be clogged with carbon deposits. Clean piston with dry cleaning solvent. Dry with low pressure compressed air. Take measurements again.

i. Inspect wrist pin for scoring, fretting, pitting, or indications of overheating. If severely damaged, replace wrist pin.

B. Repair.

1. Making Minor Repairs.

a. Remove slight scoring, or fretting on piston. Clean and repeat procedure if necessary. Refer to Table 5-3 for dimensions, tolerances, and wear limits of parts.

C. Replace.

1. Replacing/Reinstalling the Piston.

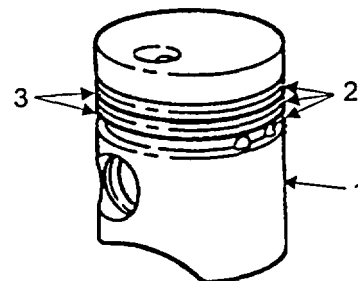

FIGURE 5-43. PISTON RING GROOVES

a. If the cylinder has been replaced, the piston must also be replaced.

CAUTION

Piston rings are marked TOP and should be installed as marked. Piston breakage may occur if rings are opened more than necessary when removing or installing them. Do Not Strain Rings.

b. If piston replacement is necessary, piston rings must also be replaced.

c. Install oil control ring (Figure 5-44, Item 1), cast iron compression ring (2) and chrome compression ring (3) in that order. Be careful not to strain rings by opening them more than necessary during installation.

d. Install new retaining ring (Figure 5-45, Item 1) in lip groove of piston (3) piston pin bore.

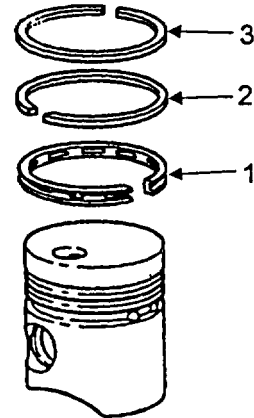

FIGURE 5-44. INSTALL PISTON RINGS

CAUTION

When installing cylinder, make sure piston or connecting rod does not knock against crankcase. This could result in damage to piston or connecting rod.

e. Insert connecting rod (Figure 5-45, Item 4) into bottom of piston (3). Make sure that opening of combustion chamber is on the flywheel side.

f. Insert wrist pin (2) into piston (3) wrist pin bore and through rod bushing of connecting rod (4) Push in wrist pin until it contacts installed retaining ring (1) and stops. Install retaining ring (5).

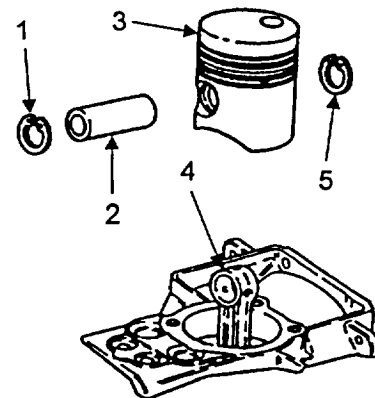

FIGURE 5-45. ASSEMBLE PISTON

5-6.7. CONNECTING ROD.

This task covers: A. Inspect B. Replace

Tools.

Shop Set, Automotive Field
Maintenance, Basic

Materials/Parts:

Diesel Fuel Oil NSN 9140-00-286-5294
Dry Cleaning Solvent NSN 6850-00-281-1985
Lubricating Oil

Equipment Conditions:

Engine Removed From Unit
Piston Removed From Engine

A. Inspect.

1. Removing the Connecting Rod for Inspection.

- a. Using hex key, remove cover (Figure 5-46, Item 1) with four caps (2) and socket head cap screws (3).

- b. Remove and discard preformed packing (4)

CAUTION

When removing cylinder, make sure piston or connecting rod does not knock against crankcase. This could result in serious damage to connecting rod.

- c. Remove two socket head cap screws (5) and remove bottom half of connecting rod (6).

- d. Remove top half of connecting rod (7) from top of crankcase.

- e. Remove two bearing halves (8) from both halves of connecting rod (6 and 7)

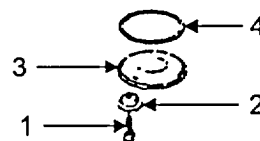
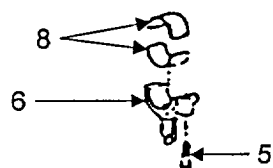
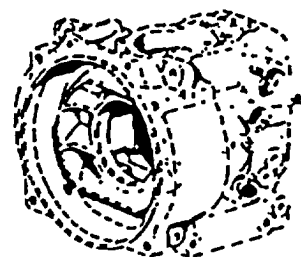

FIGURE 5-46. CONNECTING ROD

2. Cleaning and Inspecting the Connecting Rod and Bearings.

WARNING

DRY CLEANING SOLVENT P-D-680 (SAFETY OR STODDARD'S SOLVENT) IS POTENTIALLY DANGEROUS. AVOID REPEATED AND PROLONGED BREATHING OF VAPORS AND SKIN CONTACT WITH LIQUID. DO NOT USE NEAR OPEN FLAME, ARCING EQUIPMENT, OR OTHER IGNITION SOURCES. ALWAYS WEAR EYE PROTECTION AND PROTECTIVE CLOTHING. THE FLASH POINT OF P-D-680 IS 100 TO 138 DEGREES F (38 TO 59 DEGREES C).

WARNING

DEATH OR SERIOUS INJURY COULD OCCUR IF COMPRESSED AIR IS DIRECTED AGAINST THE SKIN. DO NOT USE COMPRESSED AIR FOR CLEANING OR DRYING UNLESS THE PRESSURE HAS BEEN REDUCED TO 30 PSI (2.06 BAR) OR LESS. WHEN WORKING WITH COMPRESSED AIR ALWAYS USE CHIP GUARDS, EYE PROTECTION, AND OTHER PERSONAL EQUIPMENT.

a. Clean connecting rod components with dry cleaning solvent. Remove any carbon deposits with a wire brush. Clean inside surface of rod bushing (Figure 5-46, Item 9), both connecting rod halves (6 and 7), and bearing (8). Blow compressed air through the drilled oil passage in connecting rod to clean connecting rod and rod bushing.

b. Visually inspect, connecting rod for bending, warping, cracking, rust, or other damage Check for cracks using MIL-1-6868 magnetic particle inspection Replace if twisted or bent Replace if indications of cracks are revealed by magnetic particle Inspection.

c. Measure and record rod bushing (9) inside diameter. Measure at points 1 and 2 along axis A and B (see Figure 5-47). Measurements should be 0.9850 to 0.9856 inch (25.020 to 25.033 mm) If any measurement is outside these limits, replace rod bushing.

d. Inspect upper and lower bearing halves (Figure 5-46, Item 8) for excessive wear, scoring, pitting, flaking, etching, and signs of overheating Inspect bearing backs for bright spots (bearing moving in supports).

e. Apply some oil to contact surfaces and temporarily assemble connecting rod with two new socket head cap screws and without bearings Coat the threads of the screws with oil Using a torque wrench, tighten screws to 29.50 lb.-ft (40 Nm).

f. Measure inside diameter of connecting rod bearing bore. Measurement should be 1.8114 to 1.8108 inches (46.010 to 45.994 mm). If measurement is outside specified limits, replace connecting rod.

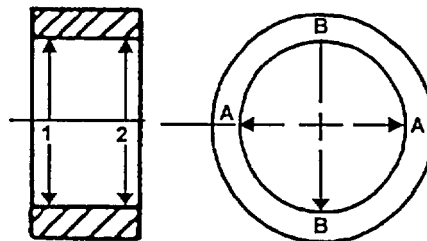

FIGURE 5-47. MEASUREMENT POINTS

g. Disassemble connecting rod carefully and insert bearing halves (8) The bottom half has a hole which matches with the connecting rod cap Reassemble connecting rod with two socket head cap screws. Tighten screws following procedures described in preceding step 5.

h. Measure inside diameter of bearing. Measure at points 1 and 2 along axis A and B. Measurements should be 1.6538 to 1.6529 inches (42.006 to 41.986 mm).

i. If any measurement is outside the tolerance limits, replace the bearing. Make sure that measurements for points 1 and 2 are not different or outside the tolerance limits, indicating that bearing is wearing in a conical shape.

j. Make sure measurements along axis A and B are not different or outside tolerance limits, indicating bearing is wearing in an oval shape.

k. If bearing is out-of-round, replace it. Follow procedure described in paragraph 5-6.12. Also check cylinder and piston for unusual wear. Follow procedures described in paragraphs 5-6.5 and 5-6.6

WARNING

DRY CLEANING SOLVENT P-D-680 (SAFETY OR STODDARD'S SOLVENT) IS POTENTIALLY DANGEROUS. AVOID REPEATED AND PROLONGED BREATHING OF VAPORS AND SKIN CONTACT WITH LIQUID. DO NOT USE NEAR OPEN FLAME, ARCING EQUIPMENT, OR OTHER IGNITION SOURCES. ALWAYS WEAR EYE PROTECTION AND PROTECTIVE CLOTHING. THE FLASH POINT OF P-D-680 IS 100 TO 138 DEGREES F (38 TO 59 DEGREES C).

WARNING

DEATH OR SERIOUS INJURY COULD OCCUR IF COMPRESSED AIR IS DIRECTED AGAINST THE SKIN. DO NOT USE COMPRESSED AIR FOR CLEANING OR DRYING UNLESS THE PRESSURE HAS BEEN REDUCED TO 30 PSI (2.06 BAR) OR LESS. WHEN WORKING WITH COMPRESSED AIR ALWAYS USE CHIP GUARDS, EYE PROTECTION, AND OTHER PERSONAL EQUIPMENT.

l. Clean rod bushing (9) and connecting rod (7) bore with dry cleaning solvent and dry with compressed air. Figure 5-46. Connecting Rod m. Inspect rod bushing or scoring, overheating, or other damage. Replace if damaged.

n. Measure outside diameter of rod bushing. Measurement should be 1.1042 to 1.1037 inches (28.048 to 28.035 mm). If measurement is outside specified limits, replace rod bushing.

o. Measure outside diameter of rod bushing bore. Measurement should be 1.1028 to 1.1024 inches (28.013 to 28.000 mm). If measurement is outside specified limits, replace connecting rod.

NOTE

Clean rust preventive from replacement connecting rod. Also make sure bearing bore is thoroughly cleaned to prevent trapped contaminants from adversely affecting bearings.

p. If required, clamp the connecting rod in a padded vise and install new rod bushing (9) into connecting rod bushing bore.

B. Replace.

1. Replacing/Reinstalling the Connecting Rod.

CAUTION

Be certain that bearing halves are installed correctly. The bottom bearing half (8) has a hole which fits into lower connecting rod half (6).

- a. Carefully insert bearing halves (Figure 5-46, Item 8) into connecting rod.

CAUTION

Be certain that the numbers on both halves of the connecting rod match. The top and bottom halves of the connecting rod fit together only one way. To provide adequate lubrication of the engine parts, the hole in the oil dipper on the bottom half of the connecting rod **MUST point in the direction of rotation of the engine in order to provide a scooping effect as the crankshaft turns. When placing the top half of the connecting rod on the journal, be sure it is in the correct position to suit the oil dipper requirement.**

- b. Install top half of connecting rod (7) on crankshaft.
- c. Install bottom half of connecting rod (6) (with dipper opening TOWARD DIRECTION OF ROTATION) and socket head cap screws (5). Using a torque wrench and socket, tighten screw to 29.50 lb.-ft (40 Nm).
- d. Lubricate preformed packing (4) with lubricating oil and install into cover (1).
- e. Install cover (1) with four caps (2) and socket head cap screws (3).

5-6 8. ENGINE TIMING COVER AND CAMSHAFT.

This task covers: A. Inspect B. Repair C. Replace

Tools:

- Shop Equipment, Automotive Maintenance and Repair
- Extractor, Cam Follower Spindle, 666 324 00
- Mounting Device, Camshaft Needle Bearing, 666 418 00
- Punch, Camshaft Needle Bearing, 66642500

Materials/Parts:

Diesel Fuel Oil NSN 9140-00-286-5294

Equipment Conditions:

- Injection Pump Removed
- Cranking Gears Removed
- Connecting Rod Removed From Engine

A. Inspect.

1. Removing/Inspecting the Timing Cover.

NOTE

Lift both cam followers from camshaft when removing timing cover to prevent bending by cam points.

- a. Remove six screws (Figure 5-48, Item 1) and washers (2) and remove timing cover (3) and camshaft (13).

CAUTION

Two threaded holes are provided in the timing cover for cap screws to be inserted to aid in removing the timing cover. Turn the cap screws evenly and alternately to push the cover straight off the crankcase.

- b. Note the two teeth of camshaft gear and one tooth of crankshaft gear that are match marked to make sure of proper alignment of timing gears when reinstalling timing cover.
- c. Remove and discard gasket (4).
- d. Remove plastic plug above injection pump, and remove socket head setscrew from crankcase.
- e. Remove spindle (5), cam followers (6 and 7) and shim (8) from crankcase using cam follower spindle extractor 66632400.

WARNING

DEATH OR SERIOUS INJURY COULD OCCUR IF FUEL IS NOT HANDLED CAREFULLY. USE IN A WELL VENTILATED AREA AWAY FROM OPEN FLAME, ARCING EQUIPMENT, IGNITION SOURCES, HEATERS, OR EXCESSIVE HEAT. ENGINE MUST BE SHUT DOWN AND COOL BEFORE REFUELING. ALWAYS STORE FUEL IN PROPER, MARKED CONTAINERS. DO NOT SMOKE.

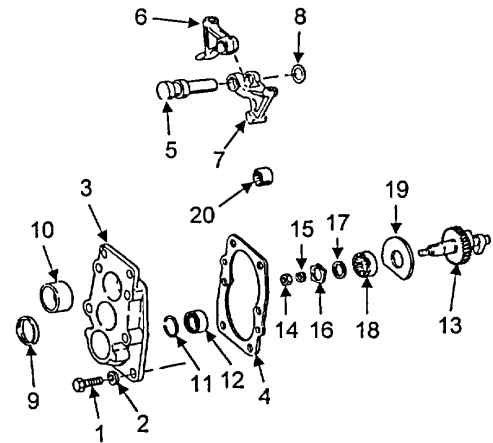

FIGURE 5-48. TIMING COVER CAMSHAFT ASSEMBLY

WARNING

DEATH OR SERIOUS INJURY COULD OCCUR IF COMPRESSED AIR IS DIRECTED AGAINST THE SKIN. DO NOT USE COMPRESSED AIR FOR CLEANING OR DRYING UNLESS THE PRESSURE HAS BEEN REDUCED TO 30 PSI (2.06 BAR) OR LESS. WHEN WORKING WITH COMPRESSED AIR ALWAYS USE CHIP GUARDS, EYE PROTECTION, AND OTHER PERSONAL EQUIPMENT.

- f. Clean timing cover with diesel fuel and dry with compressed air.
 - g. Inspect all components for damage or excessive wear. Replace any components severely damaged or worn.
 - h. Inspect surfaces of cam followers. If damaged, replace cam followers.
 - i. Inspect needle bearing (20). If damaged, replace in accordance with repair procedures.
2. Removing/Inspecting the Camshaft.
- a. Remove oil seal (9) from timing cover (3).
 - b. Collapse dry bushing (10) and remove.

CAUTION

Handling heated parts can cause severe burns. Use proper equipment to handle heated parts.

- c. Using an oven, heat timing cover to 120° F to 160° F (50° to 70°C). Remove intermediate ring (11) and drive out ball bearing (12).
- d. While timing cover is still hot, drive out camshaft (13).
- e. Remove hex nut (14), spring washer (15), retaining ring (16), flanged wheel (17), roller bearing (18) and spacer (19).

B. Repair.

1. Repairing the Timing Cover and Camshaft

WARNING

DEATH OR SERIOUS INJURY COULD OCCUR IF FUEL IS NOT HANDLED CAREFULLY. USE IN A WELL VENTILATED AREA AWAY FROM OPEN FLAME, ARCING EQUIPMENT, IGNITION SOURCES, HEATERS, OR EXCESSIVE HEAT. ENGINE MUST BE SHUT DOWN AND COOL BEFORE REFUELING. ALWAYS STORE FUEL IN PROPER, MARKED CONTAINERS. DO NOT SMOKE.

WARNING

DEATH OR SERIOUS INJURY COULD OCCUR IF COMPRESSED AIR IS DIRECTED AGAINST THE SKIN. DO NOT USE COMPRESSED AIR FOR CLEANING OR DRYING UNLESS THE PRESSURE HAS BEEN REDUCED TO 30 PSI (2.06 BAR) OR LESS. WHEN WORKING WITH COMPRESSED AIR ALWAYS USE CHIP GUARDS, EYE PROTECTION, AND OTHER PERSONAL EQUIPMENT.

- a. Reclean all parts with diesel fuel and dry with compressed air.
- b. Repair any minor damage, nicks, burrs, rust, or corrosion.
- c. If needle bearing (20) is damaged, remove using camshaft needle bearing punch 666 425 00.
- d. Replace new needle bearing (20) using camshaft needle bearing mounting device 666 418 00.

C. Replace.

1. Replacing the Camshaft.

- a. Assemble spacer (Figure 5-48, Item 19), roller bearing (18), flanged wheel (17), retaining ring (16), spring washer (15), and hex nut (14) onto camshaft (13).

CAUTION

Handling heated parts can cause severe burns. Use proper equipment to handle heated parts.

- b. Using an oven, heat timing cover (3) to 120°F to 160°F (500°C to 700°C). Drive in new ball bearing (12) and install new intermediate ring (11).
- c. While timing cover is still hot, drive in camshaft (13).
- d. Drive in new bushing (10).
- e. Install new oil seal (9).

2. Replacing the Timing Cover.

- a. Install timing cover (3).

NOTE

Make sure matchmarks on camshaft gear and crankshaft gear are aligned.

- b. Using a plastic hammer, gently tap timing cover into place.
- c. Install six screws (1) and washers (2).

5-6.9 ENGINE GOVERNOR.

This task covers: A. Inspect B. Replace

Tools:

Shop Set, Automotive Field
 Maintenance, Basic
 Impact Mandrel, Gear on
 Crankshaft 666 067 00
 Special Tool for Governor Spring
 618 305 00

Materials/Parts:

Diesel Fuel Oil NSN 9140-00-286-5294
 Grease NSN 9150-00-190-0705
 Lubricating Oil

Equipment Conditions:

Timing Cover and Camshaft Removed From
 Engine

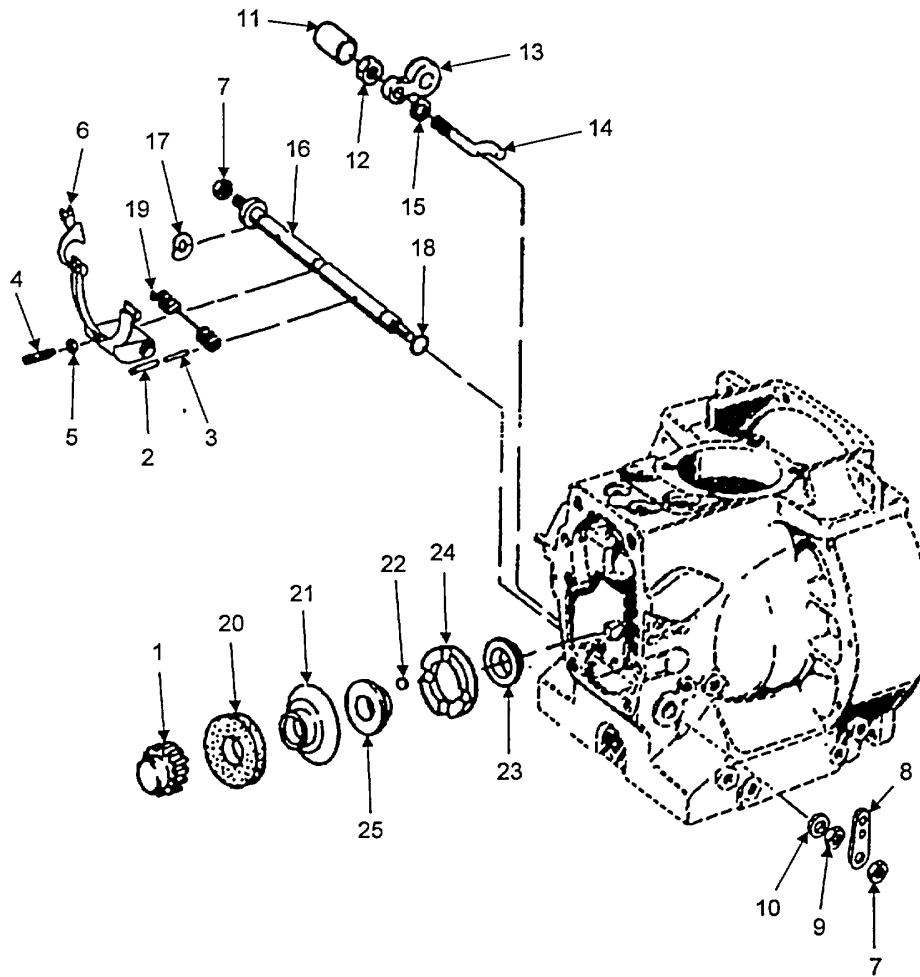

FIGURE 5-49. GOVERNOR

A. Inspect.

1. Removing the Governor for the Inspection.
 - a. Remove gearwheel (Figure 5-49, Item 1) from crankshaft.
 - b. Remove pins (2 and 3) from shaft (16)
 - c. Remove threaded pin (4) and hex nut (5) from governor lever (6).

- d. Remove two hex nuts (7) and lever (8).
- e. Remove hex nut (9) and friction disc (10)
- f. Press out shaft (16) from crankcase.
- g. Remove capsule (11), hex nut (12), plate (13) and eccentric pin (14). Discard preformed packing (15).
- h. Remove spring washer (17) and discard two preformed packing (18).
- i. Remove governor lever (6) and governor spring (19) from crankcase.
- j. Pull sliding disc (20) and ball shell (21) from crankshaft.

NOTE

Ball hub disc (23), ball hub (24) and spacer (25) are removed when the crankshaft is removed.

2. Cleaning the Parts for Inspection.

WARNING

DEATH OR SERIOUS INJURY COULD OCCUR IF FUEL IS NOT HANDLED CAREFULLY. USE IN A WELL VENTILATED AREA AWAY FROM OPEN FLAME, ARCING EQUIPMENT, IGNITION SOURCES, HEATERS, OR EXCESSIVE HEAT. ENGINE MUST BE SHUT DOWN AND COOL BEFORE REFUELING. ALWAYS STORE FUEL IN PROPER, MARKED CONTAINERS. DO NOT SMOKE.

WARNING

DEATH OR SERIOUS INJURY COULD OCCUR IF COMPRESSED AIR IS DIRECTED AGAINST THE SKIN. DO NOT USE COMPRESSED AIR FOR CLEANING OR DRYING UNLESS THE PRESSURE HAS BEEN REDUCED TO 30 PSI (2.06 BAR) OR LESS. WHEN WORKING WITH COMPRESSED AIR ALWAYS USE CHIP GUARDS, EYE PROTECTION, AND OTHER PERSONAL EQUIPMENT.

- a. Clean all parts with diesel fuel oil and dry with compressed air.
- b. Inspect all components for damage or excessive wear. Replace any components severely damaged or worn. For dimensions, tolerances, and wear limits, refer to Table 5-3, Engine Repair Data.

B. Replace.

1. Replacing the Parts.

- a. If any of the four balls (Figure 5-49, Item 22) were removed during disassembly, apply grease to four balls (22) and install balls in ball hub (24)

CAUTION

Ball shell (21) must slide easily over the crankshaft. Damage to crankshaft and governor could result from improper fitting of governor parts.

- b. Slide ball shell (21) and sliding disc (20) onto crankshaft.
- c. Lubricate preformed packing (15) with lubricating oil and install in preformed packing groove on eccentric pin (14).
- d. Install eccentric pin (14), plate (13), hex nut (12) and capsule (11) into crankcase.
- e. Mount governor spring (19) on governor lever (6) and install both parts into crankcase.

NOTE

The loop hole of the governor spring should point upward.

- f. Lubricate two preformed packings (18) with lubricating oil and install in preformed packing grooves on shaft (16).
- g. Slide spring washer (17) on shaft (16) and install into crankcase.

CAUTION

Governor lever and shaft should move freely. Do not overtighten threaded pin and lock lever on shaft. (Snug pin to bottom and unscrew 1/2 turn).

- h. Drive pins (2 and 3) through shaft until approximately 0.125 inch (3.21 mm) of roll pins protrude through reverse side of shaft (16). Using special tool 61830500, loop ends of governor spring through drive pins (2 and 3).
- i. Drive pins (2 and 3) in shaft (16) until flush with shaft j. Screw threaded pin (4) into governor lever (6) and tighten hex nut (5).
- k. Install friction disc (10), hex nut (9), lever (8), and two hex nuts (7) on shaft (16).

CAUTION

Handling heated parts can cause severe burns.

Use proper equipment to handle heated parts.

- l. Using an oven, heat timing gearwheel (l) to 160°-175°F (70°-80°C) Install gearwheel onto crankshaft using impact mandrel 66606700

5-6.10. OIL SEAL (FLYWHEEL SIDE).

This task covers: A Inspect B Replace

Tools:

Shop Set, Automotive Field
Maintenance, Basic
Flywheel Removed From Engine

Materials/Parts:

Grease NSN 9150-00-190-0705
Equipment Conditions:

A. Inspect.

- 1. Removing/inspecting the Oil Seal.

- a. Remove support (Figure 5-50, Item 1) by removing two security plates (2) and four hex screws (3). Discard preformed packing (4)

- b. Remove Oil Seal (5).

WARNING

DEATH OR SERIOUS INJURY COULD OCCUR IF FUEL IS NOT HANDLED CAREFULLY. USE IN A WELL VENTILATED AREA AWAY FROM OPEN FLAME, ARCING EQUIPMENT, IGNITION SOURCES, HEATERS, OR EXCESSIVE HEAT. ENGINE MUST BE SHUT DOWN AND COOL BEFORE REFUELING. ALWAYS STORE FUEL IN PROPER, MARKED CONTAINERS. DO NOT SMOKE.

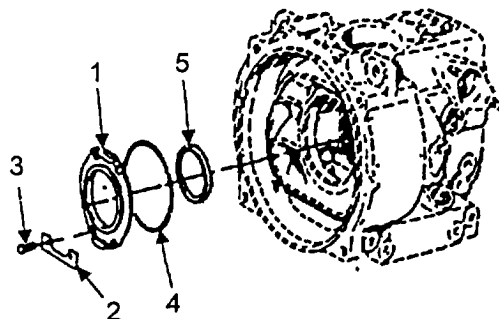

FIGURE 5-50. OIL SEAL

WARNING

DEATH OR SERIOUS INJURY COULD OCCUR IF COMPRESSED AIR IS DIRECTED AGAINST THE SKIN. DO NOT USE COMPRESSED AIR FOR CLEANING OR DRYING UNLESS THE PRESSURE HAS BEEN REDUCED TO 30 PSI (2.06 BAR) OR LESS. WHEN WORKING WITH COMPRESSED AIR ALWAYS USE CHIP GUARDS, EYE PROTECTION, AND OTHER PERSONAL EQUIPMENT.

- c. Clean oil seal components with diesel fuel and dry with low pressure compressed air.
- d. Inspect all components for damage or excessive wear. Replace any component that is severely damaged or worn.

B. Replace.

1. Replacing the Oil Seal.
 - a. oil seal in support (Figure 5-50, Item 1).
 - b. Fill groove of oil seal with grease.
 - c. Lubricate new preformed packing (4) with grease and install it in preformed packing groove in support.
 - d. Install support (1) onto crankshaft with two security plates (2) and four hex screws (3).

5-6.11. CRANKSHAFT.

This task covers: A Inspect B. Install

Tools:

Shop Set, Automotive Field
 Maintenance, Basic
 Impact Mandrel, Ball Hub,
 66606700
 Mounting Device, Crankshaft End
 Play 66607400

Materials/Parts:

Lubricating Oil
 Equipment Conditions:
 Governor Removed From Engine

A. Inspect.

1. Removing the Parts for Inspection.

CAUTION

Handling heated parts can cause severe burns. Use proper equipment to handle heated parts.

- a. Using an oven, heat crankcase to 175°F to 210°F (80°C to 100°C) Push out crankshaft (Figure 5-51, Item (1) and roller bearing outer race (3) Remove key (2).

NOTE

Balls (9), ball shell (10), and sliding disc (11) are governor components. Refer to paragraph 5-6.9 for instructions on removal of these parts.

- b. Remove and discard cover (12).
- c. Remove counterweight (13) by removing two socket head cap screws (14)

CAUTION

Handling heated parts can cause severe burns. Use proper equipment to handle heated parts

- d. Using a torch, heat roller bearing races (15 and 16) and remove them from crankshaft (1), being careful not to over heat

2. Cleaning and Inspecting the Crankshaft.

WARNING

DEATH OR SERIOUS INJURY COULD OCCUR IF FUEL IS NOT HANDLED CAREFULLY. USE IN A WELL VENTILATED AREA AWAY FROM OPEN FLAME, ARCING EQUIPMENT, IGNITION SOURCES, HEATERS, OR EXCESSIVE HEAT. ENGINE MUST BE SHUT DOWN AND COOL BEFORE REFUELING. ALWAYS STORE FUEL IN PROPER, MARKED CONTAINERS. DO NOT SMOKE.

WARNING

DEATH OR SERIOUS INJURY COULD OCCUR IF COMPRESSED AIR IS DIRECTED AGAINST THE SKIN. DO NOT USE COMPRESSED AIR FOR CLEANING OR DRYING UNLESS THE PRESSURE HAS BEEN REDUCED TO 30 PSI (2.06 BAR) OR LESS. WHEN WORKING WITH COMPRESSED AIR ALWAYS USE CHIP GUARDS, EYE PROTECTION, AND OTHER PERSONAL EQUIPMENT.

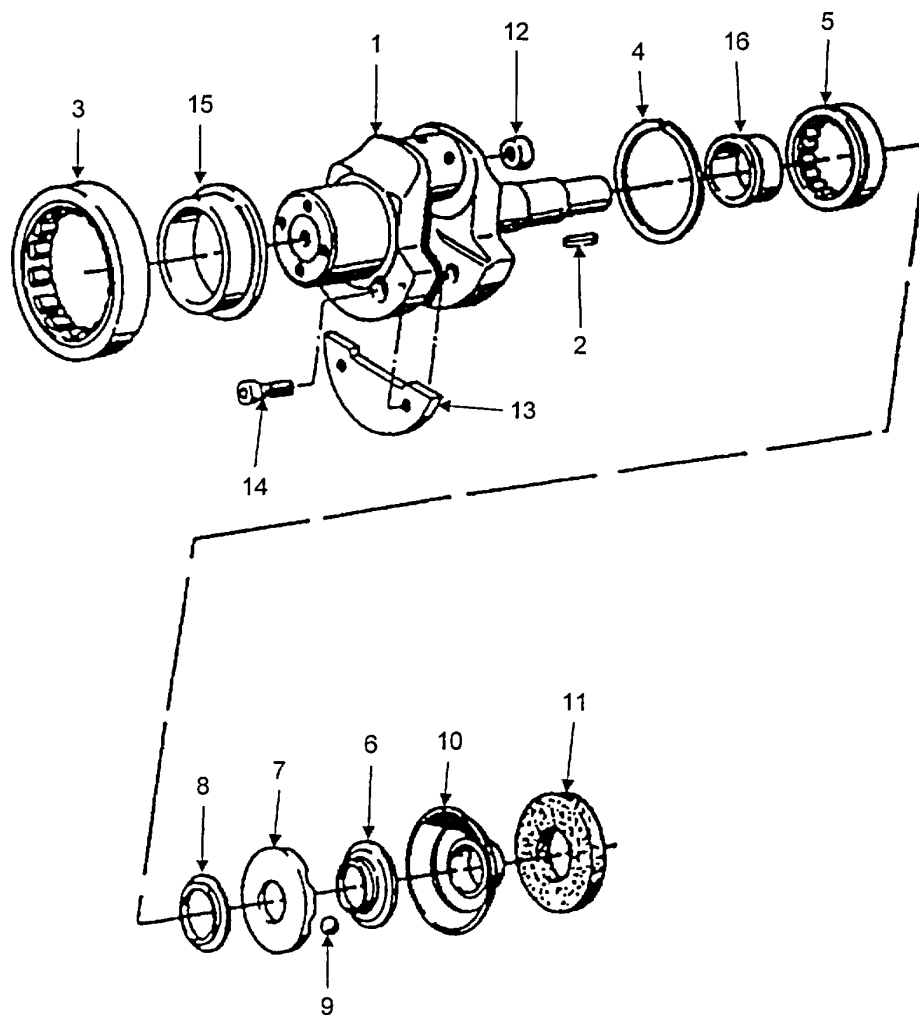

FIGURE 5-51. CRANKSHAFT

- a. Clean crankshaft components with diesel fuel and dry with compressed air. Clean oil passages with a stiff wire brush.
- b. Inspect all components for damage or excessive wear. Replace any components severely damaged or worn.

B. Install.

- 1. Installing the Crankshaft

- a. Install new cover (Figure 5-51, Item 12)
- b. Apply lubricating oil to the threads of two socket head cap screws (Figure 5-51, Item 14) and contact surface of counterweight (13). Install counterweight and two socket head cap screws. Torque socket head cap screws to 16 lb.-ft (22 Nm)

CAUTION

Handling heated parts can cause severe burns. Use proper equipment to handle heated parts

- c. Using an oven, heat the inner races of roller bearings (15 and 16) to 160°F to 175°F (70°C to 80°C) and press them onto crankshaft (1).
- d. Install retaining ring (4) into roller bearing outer race (5) and press bearing race into crankcase until it comes to a stop at the retaining ring.
- e. Push roller bearing outer race (3) onto crankshaft (1).
- f. Install crankcase end play mounting device 666 074 00 on crankshaft

CAUTION

Handling heated parts can cause severe burns. Use proper equipment to handle heated parts

- g. Using an oven, heat crankcase (1) to 175°F to 210°F (80°C to 100°C).
- h. Push in crankshaft (1) and crankcase end play mounting device 66607400 until mounting device stops. Allow crankcase to cool. Remove mounting device
- i. Using an oven, heat ball hub disc (6), ball hub (7) and spacer (8) to 175°F to 210°F (80°C to 100°C).
- j. Install spacer (8), ball hub (7) and ball hub disc (6) onto crankshaft using ball hub Impact mandrel 66606700.

NOTE

Ball (9), ball shell (10), and sliding disc (11) are governor components. Refer to paragraph 5-6.9 for instructions on installation of these parts.

5-6.12. CRANKCASE.

 This task covers: A. Inspect B. Install

Tools:

Shop Set, Automotive Field
Maintenance, Basic

Materials/Parts:

Diesel Fuel NSN 9140-00-286-5294
Lubricating Oil
O-ring 50153800 & 40022000
Gasket 50001500

Equipment Conditions:

Crankshaft Removed From Engine

A. Inspect.

1. Disassembling the Crankcase for Inspection.
 - a. Remove dipstick (Figure 5-52, Item 1) from crankcase (2). Remove and discard O ring (3).
 - b. Remove cap screw (4). Remove and discard O-ring (5).
 - c. Remove cylinder pin (6)
 - d. Remove oil drain plug (7). Remove and discard gasket (8).
2. Cleaning and Inspecting the Parts.

WARNING

DEATH OR SERIOUS INJURY COULD OCCUR IF FUEL IS NOT HANDLED CAREFULLY. USE IN A WELL VENTILATED AREA AWAY FROM OPEN FLAME, ARCING EQUIPMENT, IGNITION SOURCES, HEATERS, OR EXCESSIVE HEAT. ENGINE MUST BE SHUT DOWN AND COOL BEFORE REFUELING. ALWAYS STORE FUEL IN PROPER, MARKED CONTAINERS. DO NOT SMOKE.

WARNING

DEATH OR SERIOUS INJURY COULD OCCUR IF COMPRESSED AIR IS DIRECTED AGAINST THE SKIN. DO NOT USE COMPRESSED AIR FOR CLEANING OR DRYING UNLESS THE PRESSURE HAS BEEN REDUCED TO 30 PSI (2.06 BAR) OR LESS. WHEN WORKING WITH COMPRESSED AIR ALWAYS USE CHIP GUARDS, EYE PROTECTION, AND OTHER PERSONAL EQUIPMENT.

WARNING

LIVE STEAM USED FOR CLEANING SHALL NOT EXCEED 100 PSI (6-9 BAR). USE GOGGLES OR FACE SHIELD FOR EYE PROTECTION. DO NOT DIRECT LIVE STEAM AGAINST SKIN.

- a. Clean crankcase thoroughly with live steam. Clean all exterior openings and surfaces. Be especially sure to clean oil passages to make sure they are clear. Use a small grid or large wire bristle brush where necessary to remove carbon or other deposits from openings and surfaces. Use diesel fuel as necessary to soften and remove carbon or hardened oil deposits. Dry with compressed air.

b. Inspect crankcase for any cracks, discoloration, distortion, rust, corrosion, or other damage. If crankcase is cracked, distorted, overheated, seriously rusted or corroded on machined surfaces, or exhibits, other serious damage, replace crankcase

c. Inspect two studs (Figure 5-52, Item 9), two studs (10), and two studs (11) for thread damage or cracking. If damaged, replace studs

B. Install.

1. Installing the Crankcase.

a. Lubricate gasket (Figure 5-52, Item 8) with lubricating oil and install on oil drain plug (7). Install oil drain plug.

b. Install cylinder pin (6). c. If damaged, remove two studs (10) and two studs (11) and install new studs.

d. If damaged, remove two studs (9) and install new studs

e. Lubricate O-ring (5) with lubricating oil and install on oil filler cap (4). Install oil filler cap.

f. Lubricate O-ring (3) with lubricating oil and install on dipstick (1). Install oil dipstick in crankcase

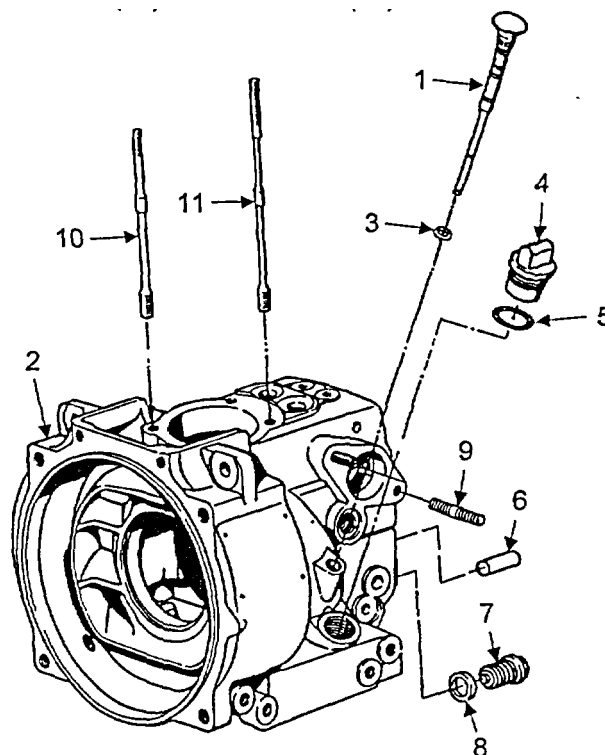

FIGURE 5-52. CRANKCASE

5-7. INSTRUMENTS GAUGES.

This task covers: A. Calibrate

Tools
 Test Stand
 Standard Certified Gauges

Materials/Parts:
 Equipment Conditions:

A. Calibrate.

1. Calibrating the Instruments Gauges.

a. Using a suitable test stand, compare system gauges against certified gauges of equal service and pressure range. Adjust system gauges as necessary.

5-8. FRAME ASSEMBLY.

This task covers: A. Repair B. Replace

Tools:

Tool Kit, General Mechanic's Set
Welding Equipment

Materials/Parts:

RTV Sealant NSN 8040- 00-225-4548

Equipment Conditions:

Compressor/Engine Removed

A. Repair.

1. Repairing the Frame.

a. Repairs to the frame are limited to replacement of damaged or distorted draw latches and to welding of cracked joints in the frame members. In case of severe bending of frame members, replacement of the frame is warranted to avoid alignment and vibration problems. The frames are manufactured to close specifications and engine units and compressor units are not required to be a matched pair. In other words, any engine section will fit satisfactorily with any compressor section. Hence, it is not necessary to replace both frames if only one is damaged enough to require replacement.

B. Replace.

1. Replacing the Frame.

a. To replace a frame, remove the included components as whole units by release of hold-down bolts and fasteners. Reinstall these units in their same configuration in a new frame assembly. Torque fasteners in accordance with Appendix F.

2. Replacing the Draw Latches.

a. Draw latches are adjustable by turning the hook section on its holding screw. However, if the hook or lever is sprung or distorted so as to be loose or otherwise defective, it must be replaced in kind. Remove the defective unit and replace it with a new one.

3. Welding the Frame.

a. Minor cracks in frame joints may be welded by a qualified welding technician using standard welding practices. If joints or frame members are broken, the frame should be replaced.

4. Installing Plastic End Caps

a. The plastic end caps (in tops of square tubes) are secured using Type I RTV Silicone Sealant

CHAPTER 6

GENERAL SUPPORT MAINTENANCE INSTRUCTIONS

		Page
Section I	General Information	6-1

Section I. GENERAL INFORMATION

Repair/test functions are to be performed by a Specialized Repair Activity (SRA). If the SRA in your geographical area does not have the capability or there is no SRA in your geographical area, utilize existing procedures for obtaining the accomplishment of the function.

APPENDIX A

REFERENCES

SCOPE

This appendix lists all Forms, Field manuals, Technical Manuals and Miscellaneous Publications referenced in this manual.

FORMS

Recommended Changes to Publications and Blank Forms DA Form 2028
 Recommended Changes to Equipment Technical Publications DA Form 2028-2
 Quality Deficiency Report SF-368
 Packaging Improvement Report DD Form 6
 Depreservation Guide DA Form 2258
 Equipment Inspection and Maintenance Worksheet DA Form 2404

TECHNICAL MANUALS

Repair Parts and Special Tools List, 5 CFM
 Compressor, Model CAPITANO-PD TM 5-4310-393-24P
 Procedures for the Destruction
 of Equipment to Prevent Enemy Use TM 750-2443
 Welding Theory and Application TM 9-237

MISCELLANEOUS PUBLICATIONS

Navy Experimental Diving Unit Instruction
 Organizational Level Cleaning of Air and Oxygen Systems NEDU 7121A

PAMPHLETS

The Army Maintenance Management System (TAMMS) DA PAM 738-750
 Navy Diving Manual 0297-LP-0019010

APPENDIX B

MAINTENANCE ALLOCATION CHART (MAC)

Section I. INTRODUCTION

1. THE ARMY MAINTENANCE SYSTEM (MAC)

a. This Introduction (Section I) provides a general explanation of all maintenance and repair functions authorized at various maintenance levels under the standard Army Maintenance System concept

b. The Maintenance Allocation Chart (MAC) in Section II designates overall authority and responsibility for the performance of maintenance functions on the identified end item or component. The application of the maintenance functions to the end item or component will be consistent with the capacities and capabilities of the designated maintenance levels, which are shown in the MAC in column (4) as:

Unit - includes two subcolumns: C (operator/crew) and O (unit) maintenance.

Direct Support - includes an F subcolumn.

General Support - includes an H subcolumn.

Depot - includes a D subcolumn

c. Section III lists the tools and test equipment (both special tools and common tools sets) required for each maintenance function as referenced from Section II.

d. Section IV contains supplemental Instructions and explanatory notes for a particular maintenance function as referenced from Section II.

2. MAINTENANCE FUNCTIONS. Maintenance functions will be limited to and defined as follows

a. **Inspect.** To determine the serviceability of an item by comparing its physical, mechanical, and/or electrical characteristics with established standards through examination (i.e., by sight, sound, or feel).

b. **Test.** To verify serviceability by measuring the mechanical, pneumatic, hydraulic, or electrical characteristics of an item and comparing those characteristics with prescribed standards.

c. **Service.** Operations required periodically to keep an Item in proper operating condition, i e, to clean (includes decontamination, when required), to replace filters, to preserve, to drain, to paint, or to replenish fuel, lubricants, chemical fluids, or gases.

d. **Adjust.** To maintain or regulate, within prescribed limits, by bringing into proper or exact position, or by setting the operating characteristics to specified parameters.

e. **Calibrate.** To determine and cause corrections to be made or to be adjusted on instruments or test, measuring, and diagnostic equipment used in precision measurement Consists of comparisons of two instruments, one of which is a certified standard of known accuracy, to detect and adjust any discrepancy in the accuracy of the instrument being compared.

f. **Remove/Install.** To remove and install the same item when required to perform service or other maintenance functions Install may be the act of emplacing, seating, or fixing into position a spare, repair part, or module (component or assembly) in a manner to allow the proper functioning of an equipment or system.

g. **Replace.** To remove an unserviceable item and install a serviceable counterpart in its place. Replace is authorized by the MAC and is shown as the 3rd position code of the SMR code.

h. **Repair.** The application of maintenance services including fault location/troubleshooting, removal /installation, disassembly/assembly procedures, and maintenance actions to identify troubles and restore serviceability to an Item by correcting specific damage, fault, malfunction, or failure in a part, subassembly, module (component or assembly), and item, or system.

3. EXPLANATION OF COLUMNS IN THE MAC, SECTION II.

a. Column 1 - Group Number. Column 1 lists functional group code numbers, the purpose of which is to identify maintenance significant components, assemblies, subassemblies, and modules with the next higher assembly.

b. Column 2 - Component/Assembly. Column 2 contains the names of components, assemblies, subassemblies, and modules for which maintenance is authorized.

c. Column 3 - Maintenance Function. Column 3 lists the functions to be performed on the item listed in column 2 (For detailed explanation of these functions, see paragraph A-2).

d. Column 4 - Maintenance Category. Column 4 specifies, by the listing of a work time figure in the appropriate subcolumn (s), the category of maintenance authorized to perform the function listed in Column 3 This figure represents the active time required to perform that maintenance function at the indicated category of maintenance. If the number or complexity of the tasks within the listed maintenance function varies at different maintenance categories, appropriate work time figures will be shown for each category. The work time figure represents the average time required to restore an item (assembly, subassembly, component, module, end item, or system) to a serviceable condition under typical field operating conditions. This time includes preparation time (Including any necessary disassembly/assembly time), troubleshooting/fault location time, and quality assurance/quality control time in addition to the time required to perform the specific tasks identified for the maintenance functions authorized in the maintenance allocation chart. The symbol designations for the various maintenance categories are as follows:

COperator or Crew

OUnit Maintenance

FDirect Support Maintenance (DS)

HGeneral Support Maintenance (GS)

DDepot Maintenance

e. Column 5 - Tools and Equipment. Column 5 specifies, by number code, those common tool sets (not individual tools); special tools; Test, Measurement, and Diagnostic Equipment (TMDE); and support equipment required to perform the designated function, which shall be keyed to the tools listed in Section III.

f. Column 6 - Remarks. This column shall, when applicable, contain a letter code, in alphabetic order, which shall be keyed to the remarks contained in Section IV.

4. EXPLANATION OF COLUMNS IN TOOL AND TEST EQUIPMENT REQUIREMENTS, SECTION III.

a. Column 1 - Reference Code. The tool and test equipment reference code correlates with a number code used in the MAC, Section II, Column 5.

b. Column 2 - Maintenance Category. The lowest category of maintenance authorized to use the tool or test equipment.

c. Column 3 - Nomenclature. Name or identification of the tool or test equipment.

d. Column 4 - National Stock Number. The National Stock Number (NSN) of the tool or test equipment.

e. Column 5 - Tool Number. The manufacturer's part number.

5. EXPLANATION OF COLUMNS IN REMARKS, SECTION IV.

a. Column 1 - Reference Code. The letter code recorded in Column 6, Section II.

b. Column 2 - Remarks. This column lists information pertinent to the maintenance function being performed as indicated in the MAC, Section II.

**Section II. MAINTENANCE ALLOCATION CHART
FOR
RECIPROCATING COMPRESSOR UNIT
MODEL CAPITANO-PD**

(1) Group - Number	(2) Component/As sembly	(3) Maintenance Function	(4) MAINTENANCE LEVEL					(5) Tools and Equipment	(6) Remarks
			UNIT		DS	GS	DEPOT		
			C	O	F	H	D		
01	COMPRESSOR	INSPECT REPLACE REPAIR ADJUST SERVICE	0.1	0.1 0.5 0.5 0.5	8.0			1, 2	
0101	COOLING SYSTEM	INSPECT REPLACE	0.1	0.3				1, 2 53-57	
0102	INTAKE FILTER ASSEMBLY	INSPECT SERVICE REPLACE	0.1 0.1	0.1				1	
0103	LUBRICATION OIL SYSTEM	INSPECT REPLACE REPAIR	2.5 0.5 0.5					1	
0104	FLYWHEEL FANWHEEL ASSEMBLY	INSPECT REPLACE REPAIR	0.1 1.0 0.5					5	
0105	VALVE HEAD ASSEMBLY - 1ST STAGE	INSPECT REPLACE REPAIR	0.1 0.3 1.5					6, 50	

(1) Group - Number	(2) Compo nent/As sembly	(3) Maintenance Function	(4) MAINTENANCE LEVEL					(5) Tools and Equipment	(6) Remarks
			UNIT		DS	GS	DEPOT		
			C	O	F	H	D		
0106	VALVE HEAD ASSEM BLY- 2ND STAGE	INSPECT REPLACE REPAIR	0.1 0.3 1.5					6, 50	
0107	VALVE HEAD ASSEM BLY- 3RD STAGE	INSPECT REPLACE REPAIR	0.1 0.3 1.5					6, 50	
0108	CYLIN DER ASSEM BLY	INSPECT REPLACE REPAIR					0.1 5.0 2.0	10, 11 12	
0109	PISTON	INSPECT REPLACE REPAIR					01 2.0 20	8, 9	
0110	CONNE CTING RODS	INSPECT REPLACE REPAIR					0.1 3.0 3.0	13, 14	
0111	CRANK SHAFT	INSPECT REPLACE					0.1 5.0		
0112	CRANK CASE	INSPECT REPLACE					0.2 4.0		
02	ENGINE ASSEM BLY	INSPECT SERVICE REPLACE REPAIR	0.2	0.2	0.2		6.0	59 1, 2, 58	
0201	OIL BATH AIR CLEAN ER	SERVICE REPLACE	0.1 0.3					1	
0202	MUFFL ER	INSPECT REPLACE	0.1 0.3					1	

(1) Group Number	(2) Compo nent/As sembly	(3) Maintenance Function	(4) MAINTENANCE LEVEL					(5) Tools and Equipment	(6) Remarks
			UNIT		DS	GS	DEPOT		
			C	O	F	H	D		
0203	HAND CRANK ASSEM BLY HANDLE	INSPECT REPLACE	0.1 0.3					51, 52	
0204	HAND CRANK ASSEM BLY GEARS	INSPECT REPLACE			0.5 1.0			51, 52	
0205	THROT TLE CONTR OL HAND LEVER	INSPECT ADJUST REPLACE			0.1 0.5 0.5			1	A
0206	V-BELT GUARD	INSPECT REPLACE	0.1	0.5				1	
0207	V-BELT	INSPECT REPLACE	0.1 0.5						
0208	FUEL LINES, HOSES AND FITTING S	INSPECT REPLACE	0.1	0.5				1,2	
0209	FUEL INJECT OR	INSPECT TEST REPLACE		0.1	1.0 1.0			3,18	B, G
0210	FUEL INJECT ION PUMP	INSPECT ADJUST TEST REPLACE		0.1	0.1 2.0 1.0			3, 48 20, 22, 47 48, 43,14	B, E
0211	CYLIN DER HEAD AND VALVE ASSEM BLY	INSPECT ADJUST REPLACE REPAIR		0.1 1.0	3.0 3.0			3, 4, 6 22, 23, 26 27, 29, 30 49, 50	A, B H, I

(1) Group Number	(2) Compo nent/As sembly	(3) Maintenance Function	(4) MAINTENANCE LEVEL					(5) Tools and Equipment	(6) Remarks
			UNIT		DS	GS	DEPOT		
			C	O	F	H	D		
0212	CYLIN DER	INSPECT REPLACE			0.1 3.0			30 44,52	B
0213	PISTO N	INSPECT REPLACE REPAIR			1.0 3.0 3.0			11,19 24,44 31,32,36	B, J
0214	CONNE CTING	INSPECT REPLACE ROD			1.0 3.0			25	B, J
0215	TIMING COVER	INSPECT REPLACE REPAIR			0.2 1.0 3.0			41	B
0216	CAMSH AFT	INSPECT REPLACE			1.0 4.0			42,45 46	
0217	GOVER NOR	INSPECT REPLACE REPAIR			1.0 4.5 4.5			15,35,39	B
0218	FLYWH EEL	INSPECT REPLACE			1.0 2.0			28	B
0219	OIL SEAL	INSPECT REPLACE			1.0 2.0			38	B
0220	CRANK SHAFT	INSPECT REPLACE			1.0 2.0			34,37,40 21,36,43	K
0221	CRANK CASE	INSPECT REPLACE REPAIR			1.0 5.0 2.0			16,17,33	
03	PURIFI CATIO N SYSTE M								
0301	PRESS URE MAINT AINING VALVE	INSPECT ADJUST REPLACE	0.1 0.1	0.1 0.1 0.2				1	
0302	PURIFI CATIO N CYLIN DER	INSPECT SERVICE REPLACE	0.1 0.3	0.2				1,60 1,60	

(1) Group Number	(2) Compo nent/As sembly	(3) Maintenance Function	(4) MAINTENANCE LEVEL					(5) Tools and Equipment	(6) Remarks
			UNIT		DS	GS	DEPOT		
			C	O	F	H	D		
0303	OIL/WA TER SEPAR ATORS	INSPECT REPLACE SERVICE	0.3	01 0.5				1	
04	INSTR UMENT S	INSPECT CALIBRATE REPLACE	0.1	0.7	1.0			1,2	
05	TUBIN G AND FITTING S	INSPECT REPLACE		0.1 0.3				1	
0501	FILL HOSE ASSEM BLY	INSPECT REPLACE		0.1 0.3					
06	FUEL TANK	INSPECT	0.1						
0601	FUEL FILTER	REPLACE		0.5				1	C
07	FRAME ASSEM BLY	INSPECT REPLACE REPAIR	0.2	2.5 1.0					D

**SECTION III. TOOLS AND TEST EQUIPMENT
FOR
RECIPROCATING COMPRESSOR UNIT
MODEL CAPITANO-PD**

TOOL OR TEST EQUIPMENT REF CODE	MAINTENANCE CATEGORY	NOMENCLATURE	NATIONAL/NATO STOCK NUMBER	TOOL NUMBER (CAGE)
1	O	Tool Kit, General Mechanic's Set	5180-00-177-7033	
2	H	Shop Equipment, Automotive Maintenance and Repair	4910-00-754-0654	
3	F	Shop Set, Automotive Field Maintenance, Basic	4910-00-754-0705	
4	F	Valve Head Wrench		004555 (57328)
5	F	Assembly Jig		011365 (57328)
6	F	Piston Ring Clamp		057493 (57328)
7	F	Piston Ring Clamp		057499 (57328)
8	F	Test Pressure Gauge		057491 (57328)
9	F	Test Pressure Gauge		057492 (57328)
10	O	Purifier Wrench		WRH-0002 (57328)
11	H	Torque Wrench		6006NMA (1CV05)
12		Testing Device		60462800 (61080)
13	F	Spill Device		66503001 (61080)
14	F	Adjusting Wrench		60600000 (61080)
15	F	Dial Gauge		61208700 (61080)
16	F	Socket		61209900 (61080)
17	F	Retaining Bracket		61275200 (61080)
18	H	Special Tool		61830500 (61080)
19	H	Impact Mandrel		66606700 (61080)
20	H	Impact Mandrel		61806900 (61080)
21	H	Oil Seal Sleeve		66607500 (61080)
22	H	Mounting Device		66641800 (61080)
3	H	Punch		66642500 (61080)
24	F	Socket Wrench (30 mm)		66833500 (61080)
25	C	Funnel, 1 Qt, Strainer with 8-in. flex spout	7240-00-550-7364	
26	O	Strap Wrench	5120-01-192-9406	

REFERENCE CODE	REMARKS
A	ADJUST TO SPECIFICATIONS IN ACCORDANCE WITH THIS TM
B	REPAIR BY REPLACING DEFECTIVE COMPONENTS
C	REPLACE ELEMENT
D	WELD
E	REPAIR BY PURGING AIR FROM FUEL SYSTEM
F	SERVICE BY CLEANING FILTER
G	TEST TIMING AND PRESSURE OUTPUT
H	INCLUDES REPLACING VALVE SEATS, GUIDES, AND MAIN BEARINGS
I	INCLUDES REPLACING BEARING, VALVES, AND GEARS
J	INCLUDES REPLACING RINGS AND ROD BEARINGS
K	INCLUDES CRANKSHAFT GRINDING

APPENDIX C**COMPONENTS OF END ITEM AND BASIC ISSUE ITEMS****SECTION I. INTRODUCTION****C-1. Scope.**

This appendix lists components of end item (COEI) and basic issue items (BII) for the 5.0 CFM Reciprocating Compressor Unit, model CAPITANO-PD to help you inventory items required for safe and efficient operation.

C-2. General.

The Components of End Item and Basic Issue Lists are divided into the following sections:

a. Section II. Components of End Item This listing is for informational purposes only, and does not give authority to requisition replacements. These items are part of the end item, but are removed and separately packaged for transportation of shipment As part of the end item, these items must be with the end item whenever it is issued or transferred between property accounts.

b. Section III. Basic Issue Items. These are the minimum essential items to place the 5.0 cfm Air Compressor, Model CAPITANO-PD in operation, to operate it, and to perform emergency repairs though shipped separately, the Basic Issue Items must be with the 5.0 cfm Air Compressor, Model CAPITANO-PD during operation and whenever it is transferred between property accounts This manual is your authority to request or requisition replacement Basic Issue Items, based on the Table of Organization and Equipment authorization of the end item.

C-3. EXPLANATION OF COLUMNS.

The following provides an explanation of the columns found in the tabular listings:

Column (1), Item Number indicates the figure and item number of the RPSTL where the item is shown.

Column (2), National Stock Number, indicates the National Stock Number assigned to the item. This will be used for requisitioning purposes

Column (3), Description, indicates the Federal Item Name for the item If required, a minimum description also provided to identify and locate the item. The last line for each item in the column identifies CAGEC (in parentheses) followed by the manufacturer's part number.

Column (4), Unit of Measure (UM), indicates the unit of measure for the quantity that Column (5) identifies. This is expressed as a two character alphabetic expression (e.g., each, in, pr).

Column (5), Quantity Required (Qty Reqd), indicates the quantity of the item authorized to be used on the equipment

SECTION II. COMPONENTS OF END ITEM

(1) Item Number	(2) National Stock Number	(3) Description CAGEC and Part Number	(4) U/I	(5 Qty Rqd)
		Tarpaulin Cover (57328) CVR-0106	ea.	1

SECTION III. BASIC ISSUE ITEMS

(1) Item Number	(2) National Stock Number	(3) Description CAGEC and Part Number	(4) U/I	(5) Qty Rqd
5-1	4240-00-022-2946	Charging Whip (57328) 18782-19	ea	1
6-1		Air Inlet Hose (57328) 18782-5	ea	1
22-1		Crank Handle, Engine (57328) HAN-0029	ea	1
		Hearing Protectors	st.	2
		Maintenance Manual (Operator, Unit, Direct Support, and General Support TM 5-4310-393-14 Repair Parts and Special Tools List, TM 5-4310-393-24		

APPENDIX D

ADDITIONAL AUTHORIZATION LIST

SECTION I. INTRODUCTION

1. SCOPE

This appendix lists additional items you are authorized for the support of the CAPITANO-PD.

2. GENERAL

This list identifies Items that do not have to accompany the CAPITANO-PD and that do not have to be turned in with it. These Items are all authorized to you by CTA, MTOE, TDA, OR JTA.

3. EXPLANATION OF LISTING

National stock numbers, descriptions, and quantities are provided to help you identify and request the additional items you require to support this equipment. The items are listed in alphabetical sequence by Item name under the type document (i.e., CTA, MTOE, TDA, or JTA) which authorizes the item(s) to you.

SECTION II. ADDITIONAL AUTHORIZATION LIST (AAL)

(1)	(2)	(3)	(4)
	DESCRIPTION		
NATIONAL STOCK NUMBER	FSCM & PART NUMBER USABLE ON CODE	U/M	QTY AUTH
<u>MTOE AUTHORIZATION ITEMS</u>			
4220-01-006-1529	CO ₂ Test Tubes	bx	1
4220-01-005-8733	CO Test Tubes	bx	1
6665-00-567-0221	Multi Gas Detector	ea. 1	
<u>CTA AUTHORIZED ITEMS</u>			

APPENDIX E

EXPENDABLE/DURABLE SUPPLIES AND MATERIALS LIST

SECTION I. INTRODUCTION

E-1. SCOPE.

This appendix lists expendable supplies and materials you will need to operate and maintain the CAPITANO-PD Reciprocating Compressor Unit. This listing is for informational purposes only and is not authority to requisition the listed items. These items are authorized to you by CTA50-970, Expendable/Durable Items (except Medical, Class V, Repair Parts, and Heraldic Items).

E-2. EXPLANATION OF COLUMNS.

a. Column (1), Item Numbers

This number is assigned to the entry in the listing and is referenced in the narrative instructions to identify the materials.

b. Column (2), Level

This column identifies the lowest level of maintenance that requires the listed item.

C	Operator or Crew
O	Organization Maintenance
F	Direct Support Maintenance
H	General Support Maintenance
D	Depot Maintenance

c. Column (3), National Stock Number

This is the National Stock Number assigned to the item; use it to request or requisition the item.

d. Column (4), Description

Indicates the Federal item name and if required, a description to identify the item. The line for each item indicates the Commercial and Government Entity Code (CAGEC) in parentheses followed by the part number.

e. Column (5), Maintenance Category

Indicates the measure used in performing the actual maintenance function. This measure is expressed by a two-character alphabetical abbreviation (e.g., ea, in, pr). If the unit of measure differs from the unit of issue, requisition the lowest unit of issue that will satisfy your requirements.

SECTION II. EXPENDABLE AND DURABLE ITEMS LIST

(1) Item Number	(2) Level	(3) National Stock Number	(4) Item Name, Description, CAGE Code, Part Number	(5) Maintenance Category
1	F	6810-00-286-5435	Alcohol: Isopropyl	gl.
2	F	6810-00-983-8551	Alcohol: Isopropyl	qt.
3	O	8415-00-281-7813	Apron: Rubber	ea.
4	O	8415-00-281-7814	Apron: Rubber	ea.
5	O	8415-00-281-7815	Apron: Rubber	ea.
6	O	8105-00-837-7757	Bag: Plastic	pk.
7	C	7530-00-222-3524	Book: Record	ea.
8	O	8020-00-224-8021	Brush: Soft Bristled	ea.
9	C	7920-00-044-9281	Cloth: Lint-free	ea.
10	F	5350-00-193-1356	Compound: Lapping and Grinding, 600 Grit	lb.
11	F	8030-00-252-3391	Compound: Sealing	oz.
12	O	7930-00-985-6911	Detergent: General Purpose MIL-D-16791	gl.
13	O	7930-00-282-9699	Detergent: Non-ionic MIL-D-16791	gl.
14	O	7930-00-985-6911	Detergent: Non-ionic MIL-D-16791	gl.
15	C	9140-00-286-5294	Fuel. Diesel, W-F-800	gl.
16	O	8415-00-266-8677	Gloves: Rubber	pr.
17	F	9150-00-754-2760	Grease: Halo Carbon	qt.
18	O	7920-00-044-4857	Brush: Stiff	ea.
19	O	8030-00-889-3534	Tape: Teflon, MIL-T-27730, % In	rl.
20	O	6810-00-297-9540	Water: Distilled, Technical	gl.

SECTION II. EXPENDABLE AND DURABLE ITEMS LIST (Continued)

(1) Item Number	(2) Level	(3) National Stock Number	(4) Item Name, Description, CAGE Code, Part Number	(5) Maintenance Category
21	O	7510-00-283-0612	Tape: Pressure Sensitive Adhesive	rl
22	O	6850-00-281-1985	Solvent Dry Cleaning, PD-680	gl
23	C	7920-00-205-1711	Rags: Wiping	bx.
24	O	8040-00-225-4548	Silicone: RTV Sealant, Type I	qt
25	H	9150-00-190-0705	Grease: Automotive and Artillery	gal.
26	O	9150-00-985-7317	Grease. Ball and Roller Bearing MI-G-21 164	gal

APPENDIX F

ILLUSTRATED LIST OF MANUFACTURED ITEMS

Section I. Introduction

This appendix includes complete instructions for making items authorized to be manufactured or fabricated at organizational, direct support, and general support maintenance.

A part number index in alphanumeric order is provided for cross-referencing the part number of the item to be manufactured to the figure which covers fabrication criteria.

All bulk material needed for manufacture of an item are listed by part number in a tabular list on the illustration.

Section II. Manufactured Items Part Number Index

Figure Number	Part Number	Nomenclature
1	EDG-0001	Black Vinyl Edging, Long
2	EDG-0001	Black Vinyl Edging, Short
3	HOS-R-0029	Fuel Hose, Vent Line
4	HOS-R-0031	Fuel Hose, Gravity Feed Line
5	18782-AU	Nylon Braided Cord
6	18782-Z	Inlet Hose, Flexible
7	N03736	Polyethylene Tube (8")

Section III. Manufactured Items Illustrations

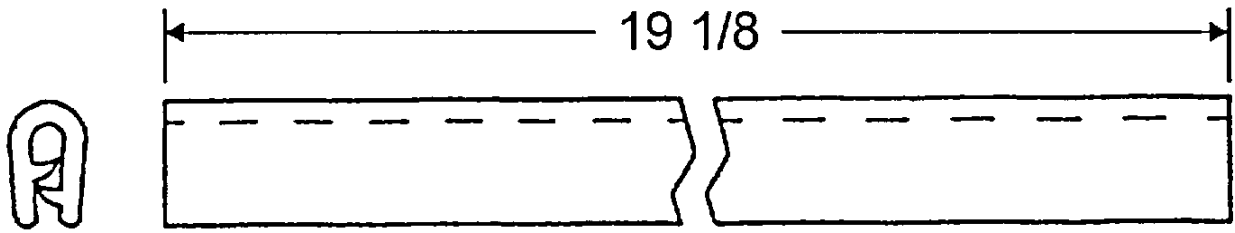

EDG- 0001

MATERIALS:

MINITRIM 75000341 Black (STANPRO)

FOR .010" TO .050" Thick edges

NOTE:

1. DIMENSIONS SHOWN ARE IN INCHES.

2. TOLERANCES ARE AS FOLLOWS:

DECIMALS ANGLES

.XX±.02±0-30'

Figure F-1.

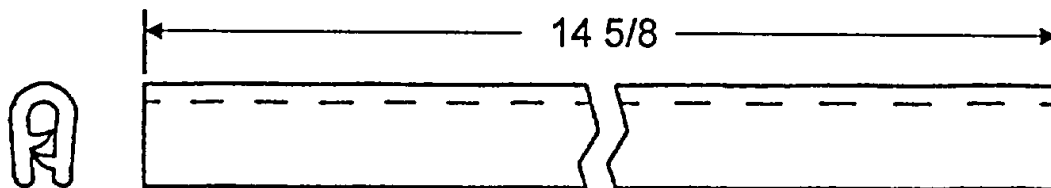

EDG- 0001

MATERIALS:

MINITRIM 75000341 Black (STANPRO)

FOR .010" TO .050" Thick edges

NOTE:

1. DIMENSIONS SHOWN ARE IN INCHES.

2. TOLERANCES ARE AS FOLLOWS:

DECIMALS ANGLES

.XX±.02±0-30'

Figure F-2.

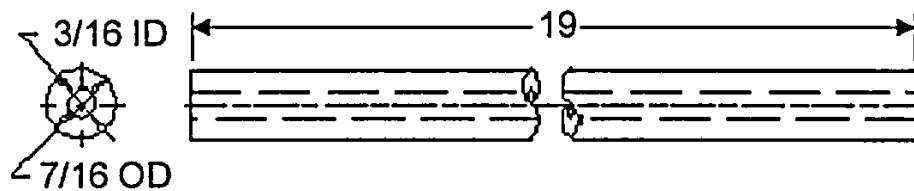

HOS- R- 0029

MATERIALS:

MAKE FROM SAE 30R6 and 30R7 Fuel Line Hose

OEM STD FOR EEC and PCV

NOTE:

1. DIMENSIONS SHOWN ARE IN INCHES.

2. TOLERANCES ARE AS FOLLOWS:

DECIMALS ANGLES

.XX±.02+0-30'

Figure F-3.

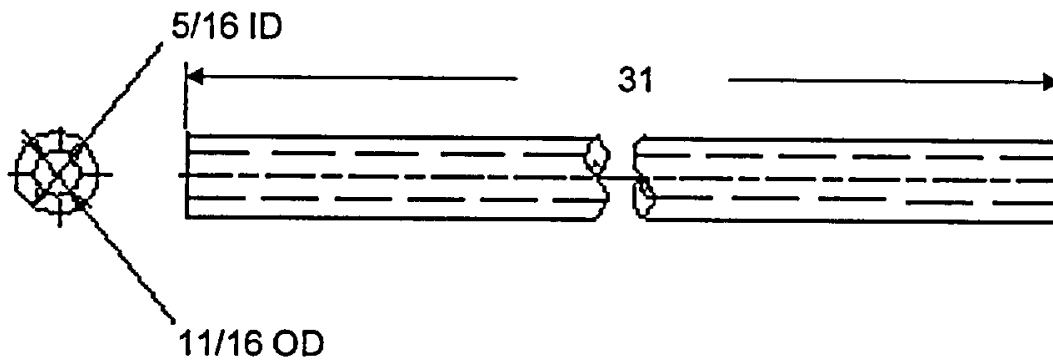

HOS-R-0031

MATERIALS:

MAKE FROM SAE J1527 USCG Type AI Fuel Hose

BIA/NMMA SPECIFICATIONS

NOTE:

1. DIMENSIONS SHOWN ARE IN INCHES.

2. TOLERANCES ARE AS FOLLOWS:

DECIMALS ANGLES

.XX±.02±0-30'

Figure F-4.

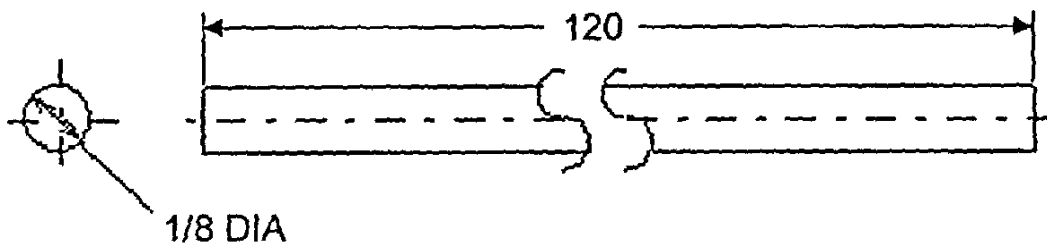

18782- AU

MATERIALS:

Solid Braided Nylon Cord

NOTE:

- 1. DIMENSIONS SHOWN ARE IN INCHES.
- 2. TOLERANCES ARE AS FOLLOWS:

DECIMALS ANGLES

.XX±.02+0-30'

Figure F-5.

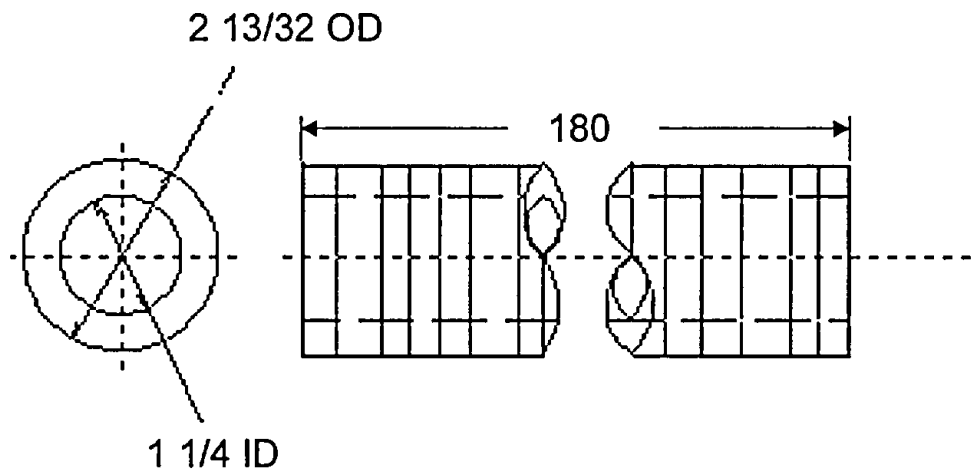

18782-Z

MATERIALS:

Copolymer Flexible Commercial Black Hose

Helically Convoluted Plastic Wall/integral Helix Design 29 in/Hg Max Vacuum.

NOTE:

1. DIMENSIONS SHOWN ARE IN INCHES.

2. TOLERANCES ARE AS FOLLOWS:

DECIMALS ANGLES

.XX±.02±0-30'

Figure F-6.

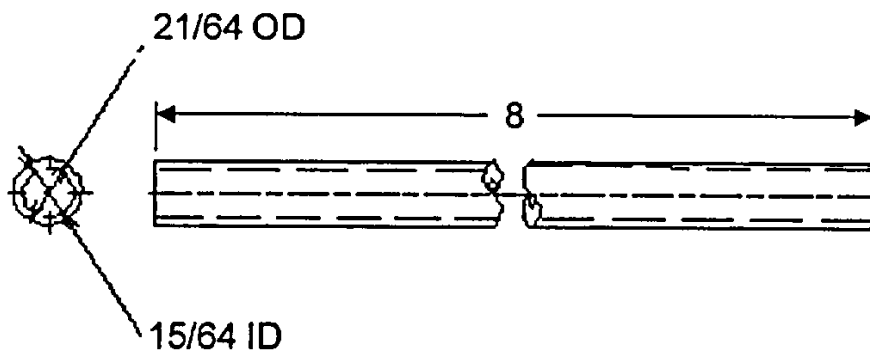

N03736

MATERIALS:

POLYETHYLENE TUBING (FESTO) 2237 PL-6

NATURAL COLOR

90 psi (6 bar)

NOTE:

1. DIMENSIONS SHOWN ARE IN INCHES.

2. TOLERANCES ARE AS FOLLOWS:

DECIMALS ANGLES

.XX±.02±0-30'

Figure F-7.

APPENDIX G

TORQUE LIMITS

NOTE

When torquing a fastener, select a wrench whose range fits the required torque value. A torque wrench is most accurate from 25% to 75% of its stated range. A wrench with a stated range of 0 to 100 will be most effective from 25 to 75 foot-pounds. The accuracy of the reading will decrease as you approach the 0 or the 100 mark.

Torque wrench setting: General for hex and Hex head screws

Thread:	M 4					
Tensile quality:	4.8	5.6	5.8	8.8	10.9	12.9
Torque: Nm/lbs Ft	4/1.03	1.3/0.96	1.7/1.25	2.8/2.06	3.9/2.88	4.7/3.47
Thread:	M 5					
Tensile quality:	4.8	5.6	5.8	8.8	10.9	12.9
Torque: Nm/lbs Ft	2.8/2.07	2.6/1.92	3.4/2.51	5.5/4.06	7.8/5.75	9.3/6.86
Thread:	M 6					
Tensile quality:	4.8	5.6	5.8	8.8	10.9	12.9
Torque: Nm/lbs Ft	4.8/3.54	4.5/3.32	6.0/4.43	9.5/7.00	13/9.59	16/11.8
Thread:	M 8					
Tensile quality:	4.8	5.6	5.8	8.8	10.9	12.9
Torque: Nm/lbs Ft	12/8.85	11/8.11	14/10.33	23/16.96	33/24.34	39/28.77
Thread:	M 10					
Tensile quality:	4.8	5.6	5.8	8.8	10.9	12.9
Torque: Nm/lbs Ft	23/16.96	22/16.23	29/21.39	46/33.93	65/47.94	78/57.53
Thread:	M 12					
Tensile quality:	4.8	5.6	5.8	8.8	10.9	12.9
Torque: Nm/lbs Ft	40/29.50	38/28.03	50/36.88	80/59.00	110/81.13	140/103.26
Thread:	M 14					
Tensile quality:	4.8	5.6	5.8	8.8	10.9	12.9
Torque: Nm/lbs ft	64/47.20	60/44.25	80/59.0	130/95.88	180/132.76	220/162.27
Thread:	M 16					
Tensile quality:	4.8	5.6	5.8	8.8	10.9	12.9
Torque: Nm/lbs Ft:	97/71.54	91/67.12	120/88.57	190/140.14	270/199.14	330/243.40
Thread:	M 18					
Tensile quality:	4.8	5.6	5.8	8.8	10.9	12.9
Torque: Nm/lbs. Ft.	130/95.88	130/95.88	170/125.88	270/199.14	380/280.28	450/331.91
Thread:	M 20					
Tensile quality:	4.8	5.6	5.8	8.8	10.9	12.9
Torque: Nm/lbs ft	190/140.14	180/132.76	240/177.02	380/280.28	530/390.91	640/472.05
Thread:	M 22					
Tensile quality:	4.8	5.6	5.8	8.8	10.9	12.9
Torque: Nm/lbs. ft.	260/191.77	240/177.02	320/236.02	510/376.16	720/531.05	860/634.31

Nm ÷ 1,3558 = lbs Ft Nm ÷ 9,81 (10)= kpm

Specific Torque Limits for Engine

	Nm	lbs ft	Notes:
Hex. nuts M 8 x 1(Cylinder head nuts)	35	26	HE 673:
Connecting rod bolts	40*	30*	Tighten cylinder head evenly and cross-wise to the specified torque.
Allen screws M 8 (counterweights)	22*	16*	From this point tighten cylinder head (hex. nuts) for further 45° by using socket and T-bar.
Hex, nut M 8; retaining injector	15		
Hex, nut M6; retaining Injector	10	7.5	
Allen screws M 10 (flywheel)	70	52	
Delivery valve holder on Injection pump	40	30	
Hex Screws M 6 (Oil seal retaining cover flywheel side)	10	7.5	
Allen screws M 8 (blower ring)	30	22	
Injector cap nut (nozzle retention)	85	63	
Cap nut (fuel pressure pipe)	25	18	

*Apply some oil to threads and contact surfaces.

SPECIFIC TORQUE LIMITS FOR COMPRESSOR

COMPRESSOR VALVE HEADS:

Thread size	torque setting
M 6	10 Nm/ 7.3 lb. x ft.
M 8	25 Nm/18 0 lb x ft.
M 10	45 Nm/33 0 lb x ft. 10 Nm ~ 1 kpm

Tightening Sequence

Tighten the valve head fasteners equally and in a crosswise order observing the above torque settings.

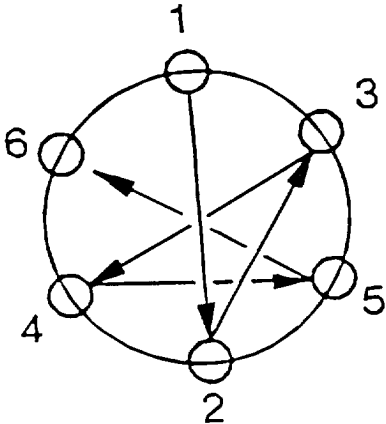
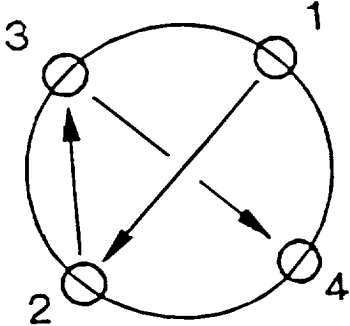

INDEX

A
B
C

Compressor..... 4-36
 Connecting Rod..... 5-37
 Cooling System 4-15
 Crankcase..... 5-51
 Crankshaft..... 5-48
 Cylinder Head And Valve Assembly 5-18

D

Drive V -Belt 3-17

E

Engine Cylinder Head And Valve Assembly..... 4-12
 Engine Cylinder 5-28
 Engine Equipment..... 5-2
 Engine Exhaust Muffler And Spark Arrester 3-23
 Engine Flywheel 5-7
 Engine Fuel Lines, Hoses, And Fittings 3-24
 Engine Governor..... 5-44
 Engine Oil Bath Air Cleaner Filter..... 3-21
 Engine Oil Change Procedure..... 3-2
 Engine Oil Change..... 3-1
 Engine Oil Level..... 3-20
 Engine Piston 5-32
 Engine Timing Cover And Camshaft..... 5-40
 Engine Unit..... 4-36

F

Fuel Injection Pump 5-9
 Fuel Injector..... 4-14

G
H

Hand Crank Assembly Gears..... 5-16

I

Impeller/Groove Pulley 4-18
 Intake Air Cleaner Filter..... 3-18
 Intermediate Filter..... 3-19

J
K
L

Lubricating System 4-16
 Lubrication Oils..... 4-36
 Lubrication System 3-15

M
N
O

Oil Change Procedure..... 3-3
 Oil Level Check 3-3
 Oil Pressure Regulator..... 3-4
 Oil Seal (Flywheel Side) 5-47
 Oil/Water Separator 3-27
 Operation Under Severe Conditions 3-3

P

Preserving The Compressor 4-35
 Preserving The Engine..... 4-35
 Pressure Maintaining Valve 3-26
 Purification Cylinder 3-26

Q
R

Replace Compressor..... 4-28
 Replace Compressor..... 4-28

S
T

Throttle Control Hand Lever..... 3-24

U
V

Valve Head Assembly, First Stage 4-19
 Valve Head Assembly, Second Stage 4-22
 Valve Head Assembly, Third Stage..... 4-25
 Venting the Compressor Oil Pump 3-4

W
Y
Z

By Order of the Secretary of the Army:

DENNIS J. REIMER
General, United States Army
Chief of Staff

Official:

JOEL B. HUDSON
Administrative Assistant to the
Secretary of the Army
05503

DISTRIBUTION: To be distributed in accordance with the Initial Distribution Number (IDN) 255138, requirements for TM 5-4310-393-14.

☆U.S. GOVERNMENT PRINTING OFFICE: 1999-746-025/80142

RECOMMENDED CHANGES TO EQUIPMENT TECHNICAL PUBLICATIONS



SOMETHING WRONG

WITH THIS PUBLICATION?

THEN JOT DOWN THE DOPE ABOUT IT ON THIS FORM CAREFULLY TEAR IT OUT. FOLD IT AND DROP IT IN THE MAIL

FROM (PRINT YOUR UNIT'S COMPLETE ADDRESS)

PFC John Doe
11th Div's Det
Fort Eustis, VA 23502

DATE SENT

18 Dec 1998

PUBLICATION NUMBER

TM 5-4310-393-14

PUBLICATION DATE

15 March 1999

PUBLICATION TITLE

Compressor, 5.0 CFM, CAPITANO-PD

BE EXACT . . . PIN-POINT WHERE IT IS

PAGE NO	PARA-GRAPH	FIGURE NO	TABLE NO
1-25	1-146		

IN THIS SPACE TELL WHAT IS WRONG AND WHAT SHOULD BE DONE ABOUT IT:

In step A1b, change
'vau' head (10), to read
'valve head (10), to correct misspelled word

TEAR ALONG PERFORATED LINE

SAMPLE

PRINTED NAME, GRADE OR TITLE, AND TELEPHONE NUMBER

John Doe PFC, (757) 878-5658

SIGN HERE

JOHN DOE

DA FORM 1 JUL 79 2028-2

PREVIOUS EDITIONS ARE OBSOLETE

PS . . . IF YOUR OUTFIT WANTS TO KNOW ABOUT YOUR RECOMMENDATION MAKE A CARBON COPY OF THIS AND GIVE IT TO YOUR HEADQUARTERS

RECOMMENDED CHANGES TO EQUIPMENT TECHNICAL PUBLICATIONS



SOMETHING WRONG

WITH THIS PUBLICATION?

THEN JOT DOWN THE DOPE ABOUT IT ON THIS FORM. CAREFULLY TEAR IT OUT. FOLD IT AND DROP IT IN THE MAIL.

FROM (PRINT YOUR UNIT'S COMPLETE ADDRESS)

DATE SENT

PUBLICATION NUMBER

TM 5-4310-393-14

PUBLICATION DATE

15 March 1999

PUBLICATION TITLE

Compressor, 5.0 CFM, CAPITANO-PD

BE EXACT . . . PIN-POINT WHERE IT IS

IN THIS SPACE TELL WHAT IS WRONG AND WHAT SHOULD BE DONE ABOUT IT:

PAGE NO	PARA-GRAPH	FIGURE NO	TABLE NO
---------	------------	-----------	----------

TEAR ALONG PERFORATED LINE

PRINTED NAME, GRADE OR TITLE, AND TELEPHONE NUMBER

SIGN HERE

DA FORM 1 JUL 79 **2028-2**

PREVIOUS EDITIONS ARE OBSOLETE.

PS . . IF YOUR OUTFIT WANTS TO KNOW ABOUT YOUR RECOMMENDATION MAKE A CARBON COPY OF THIS AND GIVE IT TO YOUR HEADQUARTERS

FILL IN YOUR
UNIT'S ADDRESS

FOLD BACK

TEAR ALONG PERFORATED LINE

DEPARTMENT OF THE ARMY



OFFICIAL BUSINESS
PENALTY FOR PRIVATE USE, \$300

NO POSTAGE
NECESSARY
IF MAILED
IN THE
UNITED STATES

BUSINESS REPLY MAIL
FIRST CLASS BRM PERMIT NO. 82 WASHINGTON D.C.

POSTAGE WILL BE PAID BY DEPARTMENT OF THE ARMY

DIRECTOR
ARMAMENT AND CHEMICAL ACQUISITION
AND LOGISTICS ACTIVITY
ATTN: AMSTA-AC-NML
ROCK ISLAND, IL 61201-9948



